



SUPPLEMENT TO
STATE OF OHIO DEPARTMENT OF TRANSPORTATION
CONSTRUCTION AND MATERIAL SPECIFICATIONS
Dated January 1, 2016

Copies of the City of Cincinnati Supplement to the State of Ohio Department of Transportation, Construction and Material Specifications may be purchased by contacting:

Right-of-Way Management Section
City of Cincinnati
801 Plum Street, City Hall–Room 425
Cincinnati OH 45202

(513) 352-3463

Or found on the City's website at: www.cincinnati-oh.gov/dote

CITY SUPPLEMENT TO 2016 OHIO DEPARTMENT OF TRANSPORTATION CONSTRUCTION AND MATERIAL SPECIFICATIONS

Foreward

The City Administration, in an attempt to promote uniform construction practices throughout the area, has adopted the State of Ohio, Department of Transportation, Construction and Material Specifications for control of its construction program.

The City wrote this Supplement to amend the State Specifications dated January 1, 2016. The Supplement permits adaptation of City operation and control and also includes construction items needed by the City but not included by the State.

Approved:



Donald G. Gindling, P.E.

August 1, 2016

Date:
City Engineer
City of Cincinnati

TABLE OF CONTENTS

100	General Provisions	1
101	Definitions and Terms	1
102	Bidding Requirements and Conditions	3
103	Award and Execution of Contract	4
104	Scope of Work	6
105	Control of Work.....	8
106	Control of Material	11
107	Legal Relations and Responsibility to Public.....	12
108	Prosecution and Progress	19
109	Acceptance, Measurement and Payment.....	24
200	Earthwork	28
Item 201	Clearing and Grubbing	28
Item 202	Removal of Structures and Obstructions.....	29
Item 203	Roadway Excavation and Embankment	32
Item 204	Subgrade Compaction and Proofrolling	33
Item 210	Special Excavation.....	34
Item 211	Special Fill Material	34
250	Pavement Repairs	35
Item 251	Partial Depth Pavement Repair	35
Item 252	Full Depth Rigid Pavement Removal and Flexible Replacement	35
Item 253	Pavement Repair	36
Item 254	Pavement Planning.....	37
Item 255	Full Depth Rigid Pavement Removal and Rigid Replacement	38
300	Bases	38
Item 304	Aggregate Base.....	38
400	Flexible Pavement.....	39
Item 401	Asphalt Concrete Pavements – General	39
Item 403	Asphalt Concrete Quality Control and Acceptance.....	40
Item 421	Microsurfacing	40
Item 442 & Item 448	Super Pave Asphalt Concrete	41
450	Rigid Pavement.....	41

Item 451	Reinforced Portland Cement Concrete Pavement	41
Item 452	Non-Reinforced Portland Cement Concrete Pavement	42
500	Structures	42
Item 501	Structures – General	42
Item 509	Reinforcing Steel	44
Item 511	Concrete for Structures	44
Item 512	Treating Concrete.....	44
Item 513	Structural Steel Members.....	45
Item 519	Patching Concrete Structures	45
Item 520	Pneumatically Placed Mortar	45
Item 524	Drilled Shafts	45
600	Incidentals	46
Item 601	Slope and Channel Protection	46
Item 602	Masonry	47
Item 603	Pipe Culverts, Sewers and Drains	48
Item 604	Manholes, Catch Basins, Inlets, Inspection Wells, Junction Chambers, Precast Reinforced Concrete Outlets, or Monuments....	72
Item 608	Walks, Curb Ramps and Steps	78
Item 609	Curbing, Concrete Medians and Traffic Islands	83
Item 611	Pipe Culverts, Sewers, Drains, and Drainage Structures.....	84
Item 612	Tree Grates and Guards.....	84
Item 613	Low Strength Mortar Backfill	86
Item 614	Maintaining Traffic	86
Item 627	Driveways.....	91
Item 628	Sawing Concrete	93
Item 629	Curbs Reset	93
Item 630	Traffic Signs and Sign Supports	94
Item 634	Project Sign	96
Item 635	Cutting and Trimming Old Granite Curbs.....	98
Item 636	Bicycle Rack.....	98
Item 637	Sheeting and Bracing Ordered Left in Place	100
Item 639	Architectural Poles and Accessories.....	101
Item 639.1	Caulking and Sealants	102
640	Pavement Marking	106
Item 641	Pavement Marking - General.....	106
650	Roadsides.....	107
Item 657	Riprap for Tree Protection.....	107

Item 658	Tree Root Aeration	107
Item 660	Sodding.....	108
Item 661	Planting Trees, Shrubs, Perennials, and Vines.....	108
Item 663	Ornamental Light Attachments in Trees	109
Item 664	Structural Soil Mix	109
Item 665	Planting Salvaged Plants.....	110
Item 666	Pruning Existing Trees	110
Item 667	Large Trees Moved and Reset	111
Item 669	Seeding and Other Matting Materials	113
Item 670	Erosion Protection	113
700	Material Details.....	114
700	Minimum Requirements for Sampling Materials	114
703	Aggregate.....	114
704	Masonry Units	115
706	Concrete and Clay Pipe	115
707	Steel, Aluminum and Plastic Pipe	118
708	Paint	119
711	Structural Steel and Structure Incidentals.....	121
712	Miscellaneous.....	121
713	Sealant Materials	123
730	Traffic Sign and Support Material	124
1100	Water Main Work	124
1100	General Provisions	124
1101	Laying Pipe and Fittings.....	127
1102	Hauling Water Works Materials	145
1103	Lowering Existing Water Mains	146
1104	Installing Valves on Existing Water Mains	147
1105	Plugging Existing Water Mains and Fittings.....	148
1106	Furnishing and Installing Foamglas Pipe Insulation	149
1107	Furnishing and Installing Tunnel Liner.....	150
1108	Furnishing and Installing Steel Casing	151
1109	Excavating for Tapping Sleeve and Valve.....	153
1110	Concrete	153
1111	Water Works Chambers	155
1112	Hauling and Installing Fire Hydrants.....	160
1113	Relocating Existing Fire Hydrants	161
1114	Removing Fire Hydrants	162
1115	Furnishing and Installing Fire Hydrant Extensions	163
1116	Installing Valve Boxes Complete	164
1117	Field Welding Tied Joints, Concrete Pipe.....	165
1118	Salvaging Existing Water Mains and Fittings	165

1119	Additional Excavation	167
1120	Exploratory Excavation	168
1121	Filling Abandoned Water Works Structures.....	169
1122	Removing Existing Manhole Curbs and Covers and Valve Boxes	170
1123	Changing Pipe Sewers	171
1124	Furnishing, Installing, and Maintaining Temporary Water Mains	172
1125	Resetting Existing Valve Boxes Complete	173
1126	Installing and Connecting Copper Service Pipe	174
1127	Lowering Existing Service Branches	176
1128	Reconnecting Existing Copper Service Branches	176
1129	Installing Stop Cocks in Existing Lines	178
1130	Disconnecting Existing Service Branches 5/8 Inch Through 2 Inch	178
1131	Installing Curb and Roadway Boxes.....	180
1132	Resetting Existing Curb and Roadway Boxes	180
1133	Furnishing and Installing Frost-Proof Meter Settings Complete	181
1134	Relocating Existing Frost-Proof Meter Settings	182
1135	Resetting Existing Frost-Proof Meter Settings	183
1136	Furnishing and Installing Frost-Proof Meter Setting Appurtenances	183
1137	Furnishing and Installing Meter Settings (Domestic or Fire), Backflow Preventers, and Appurtenances and Construct Pits	185
1138	Removing Curb and Roadway Boxes	185
1300	Installation of Street Lighting Equipment and Traffic Control Devices	186
1301	Description	186
1302	References	186
1303	Materials	187
1304	Utilities, Permits and Regulations	188
1305	Coordination.....	189
1306	Working Plans.....	189
1307	Standard Drawings	189
1308	Equipment Furnished by the City.....	190
1309	Installation Practices	191
1310	Definitions.....	192
1311	Inspections.....	193
1312	Electric Power Service	193
1313	Testing.....	194
1314	Maintenance of Traffic and Systems.....	195
1315	Temporary Systems	198
1316	Removal of Existing Equipment.....	199
1317	Painting	201
1318	Poles and Supports	203
1319	Foundations	212
1320	Grounding Equipment.....	214
1321	Conduit, Risers and Trenching	215

1322	Electrical Boxes	218
1323	Cables, Connectors and Accessories	222
1324	Traffic and Lighting Controls	228
1325	Street Lighting Luminaires	237
1326	Lamps	244
1327	Traffic Signals	247
1328	Traffic Signal Detectors	275
1329	Traffic Control Signs and Installations	284
1330	Pav't. Marker Buttons and Longitudinal Channelizing Systems	294
1331	Traffic Island Lighting	296
1332	Relocation of Existing Equipment	297
1333	Modification of Existing Lighting Circuits	298
1334	Restoration of Work Areas	299
1335	Cable and Pole Identification	299
1336	Method of Payment	299
1337	Turn On-Off Records	300

NOTE: Additions, deletions, and modifications to the text from the 2013 version of this Supplement are indicated by vertical lines in the margins.

100 GENERAL PROVISIONS

101 Definitions and Terms

101.01 General.

Add:

Consistent with ODOT CMS these specifications are written to the Bidder before award of the Contract and to the Contractor after award of the Contract. The sentences that direct the Contractor to perform Work are written as commands.

Amend State of Ohio Specification to add:

As defined in Section 101.03, change to the City Manager all references to the Director, the Director of Transportation, the Assistant Directors of Transportation, the Deputy Director of the Division of Construction Management, the Deputy Director of the Division of Operations, the Deputy Director of the Division of Planning, the Deputy Director of the Division of Engineering, the Executive Director of the Ohio Rail Development Commission, the Engineer of Bridges, the Engineer of Construction, the Engineer of Maintenance, or the Engineer of Tests.

As defined in Section 101.03, change to Engineer all references to District Construction Administrator, Final Inspector, Office of Material Management, Office of Geotechnical Engineering and District Deputy Director.

As defined in Section 101.03, change to the City all references to the State, the State of Ohio, the Department, the Department of Transportation, or the Transportation Department.

Apply all references to Sections of the Ohio Revised Code (ORC) or Director's Journal Entry to the applicable Sections of the Cincinnati Municipal Code, which will prevail.

101.02 Abbreviations. Add:

GCWW - Greater Cincinnati Water Works.

101.03 Definitions.

Addenda. Corrections to bid documents sent out by the City's Purchasing Division.

City. The City of Cincinnati, acting through the City Manager or the designated representative of the City Manager or independent board or commission and the head of the department or division directing the work.

City Manager. The City Manager of the City of Cincinnati acting in the official capacity on behalf of the City of Cincinnati, or a duly authorized agent.

City of Cincinnati Purchasing Division. The Purchasing Agent for the City.

Completion Date. Substitute: "Substantial Completion" for "Completion".

GCWW Distribution Storage Yards. GCWW material storage facilities at 3845 Eastern Avenue and 4747 Spring Grove Avenue, Cincinnati, Ohio.

GCWW Inspector. The Greater Cincinnati Water Works Inspector acting in behalf of the Director of the Water Works.

GCWW Plans. Plans, profiles, cross-sections, working drawings, detail drawings, and tabulated laying schedules approved by the GCWW, which show the locations, character, dimensions, and details concerning the construction of water mains, appurtenances, and associated work.

GCWW Standard Drawings. The City of Cincinnati, Department of the Water Works Engineering Division Standard Drawings available from the Director of Water Works Engineering Records Section, 4747 Spring Grove Avenue.

GCWW Director. The Director of Water Works acting in the official capacity as the duly authorized agent of the City Manager.

Emergency. Any situation or condition that constitutes, in the opinion of the City, such a threat to people or property that warrants action by the City without notice to the Contractor. The City will provide written declaration of emergency to the Contractor after the fact and within one week of the Contractor's request.

Laboratory. Delete these sections and substitute:

A reputable testing laboratory delegated by or acceptable to the City Manager for rendering testing and inspection services on a contract where these Specifications govern.

Project. Delete this section and substitute:

The specific section of the work together with all appurtenances and construction to be performed thereon under the Contract.

Public Works Inspector. Individual assigned by the Engineer to administer the Contract or permit.

Right-of-Way. Delete this section and substitute:

A general term denoting land, property, or interest therein, acquired for or devoted to a street. City-owned or dedicated property for passage of the public.

Rules and Regulations of the GCWW "Greater Cincinnati Water Works Laws, Ordinances, Rules and Regulations" available from the Superintendent of the Commercial Division, 4747 Spring Grove Avenue.

Rules and Regulations of the City Stormwater Management Utility. "Cincinnati Stormwater Laws, Ordinances, Rules and Regulations" available from the City Stormwater Engineer, 225 West Galbraith Road, Cincinnati, OH 45216.

Street. Delete this section and substitute:

Street means Street as defined in Section 721-1-52 of the City of Cincinnati Municipal Code.

Standard Drawings. The City of Cincinnati Department of Transportation and Engineering/Traffic Engineering Division and Engineering Division; the City of Cincinnati Metropolitan Sewer District of Greater Cincinnati (MSDGC); Greater Cincinnati Water Works; and the MSDGC/ Division of Stormwater Management may, from time to time, publish drawings that describe standard requirements, details, and materials incorporated as applicable to the Contract or permit.

Street Restoration Book. Rules and regulations issued by the City Engineer that regulate activities and materials within the street.

Subcontractor. Delete this section and substitute:

An individual, firm or corporation to whom the Contractor sublets part of the Contract to be performed on the job site, who prior to such undertaking, receives written consent of the City Manager through a Form 208 Subcontractor Approval Form.

Subdivision and Development Streets Manual. Rules and regulations issued by the City Engineer that regulates the engineering design of streets for private subdivisions or developments.

102 Bidding Requirements and Conditions

102.01 Prequalification of Bidders. Delete this section.

102.05 Examination of Bid Documents and Project Site and Submission of Prebid Questions.

Delete the last paragraph regarding submitting a Prebid Question.

102.06 Preparation of Bids. Delete this section and substitute:

Submit the Bid upon the forms contained in the "Bid Document". Specify the amount of labor and materials, in figures, in the columns provided for that purpose, for each unit of each pay item for which a quantity is given and also show the sum of labor and materials costs, in figures, in the column provided for that purpose on the forms. List the unofficial total of the bid on the line provided for that purpose.

Place the required signature in ink in the space provided.

102.07 Duty to Notify of Errors in Bid Documents. Substitute: City's Purchasing Agent for Department. Delete the second sentence of the first paragraph.

102.09 Proposal Guaranty. Delete this section and substitute:

The City will not consider any proposal unless it accompanies a bid surety or certified check drawn on a solvent bank in an amount not less than ten percent of the Bidder's Proposal. In no event shall the amount of the Proposal Guaranty be less than \$500.00. Facsimiles may satisfy this requirement, provided that bidder provides substantive protection as specified herein.

102.10 Delivery of Bid. Delete the first sentence.

102.11 Withdrawal of Bids. Delete this section and substitute:

A Bidder may withdraw or modify the Contractor's Proposal, provided the written request is in the hands of the City Purchasing Agent by the time limit set for receiving Proposals. Mark such communications so as to indicate their nature. The City Purchasing Agent will read them aloud at the bid reading before opening any of the Proposals. When opening any Proposal affected by such a communication, the City Purchasing Agent will return it to the Bidder or modify it in accordance with the communication.

102.12 Combination Proposals. Delete this section and substitute:

No combination bid will be considered except as set forth in bid document.

102.14 Disqualification of Bidders. Delete paragraphs A., I., and M.

102.16 Certificate of Compliance with Affirmative Action Programs. Delete this section.

102.17 Drug-Free Safety Program. Delete this section.

103 Award and Execution of Contract

103.01 Consideration of Proposals. Delete first paragraph and substitute:

The City will open and read the Proposals, then check the separate prices bid for labor and material against the total price bid for each item. If any error exists, the total combined unit price will be used, except in cases where the Bidder plainly indicates his intent to be otherwise. However, the City reserves the right to reject any bid in which, in its opinion, the Bidder's intent is uncertain. The City will check the unit prices, make extensions and compute and compare totals.

103.02 Award of Contract. Delete this section and substitute:

The Award of the Contract will be made to the lowest or best Bidder whose Proposal complies with all the requirements prescribed. In no case will the City award the Contract until making all necessary investigations as to the responsibility of the winning Bidder.

The City Manager reserves the right to require the Bidder to present satisfactory evidence that the Bidder has been regularly engaged, as either principal or superintendent, in the business of construction work similar to that proposed herein, and to require the Bidder to present satisfactory evidence that the Bidder is fully prepared with the necessary capital, material, machinery and equipment to conduct the work to be contracted to the satisfaction of the City, and to begin promptly when so ordered. Failure to have performed satisfactorily on any Contract awarded to the Bidder shall be sufficient reason for rejection of the Proposal.

103.05 Requirement of Contract Bond (Performance Surety). Delete this section and substitute:

Within ten days after receiving notice of the Award and before entering into a Contract, furnish a Contract Bond in the full amount of the Proposal, which bond shall cover the entire Contract including the correction and repair period required under 109.12. Execute the Contract Bond on the form contained in the Contract. Agents of bonding companies must furnish evidence of their power of attorney, bearing the seal of the company authorizing them to execute the particular type of bond to be furnished.

If, at any time after the approval of the Contract Bond and the execution of the Contract, the City shall deem the surety or sureties upon the bond to be unsatisfactory, or if for any reason the bond shall cease to be adequate security for the City, within five days after notice from the City to do so, furnish a new or additional bond which shall be adequate and satisfactory to the City.

The City will make no further payment under the Contract to the Contractor unless and until Contractor furnishes such new or additional City approved bond.

103.06 Execution of Contract. Delete this section and substitute:

Sign and return the Contract, together with the Contract Bond and other required Contract Documents, within ten days after the Bidder receives notice of the Contract award. Provide required signatures as follows:

Corporation: If a corporation, the Contractor must sign the Contract with full name of the corporation, followed by the signature of the President, Vice-President, or persons authorized to bind it in the matter. Should other than the President or Vice-President sign the Contract, the company must evidence authorization to bind by attaching a certified copy of the extracts of the minutes of this corporation.

Partnership: If a partnership, the Contractor must give the full name of all the partners composing the same, and one or more of the partners must sign the Contract in the following manner:

"John Jones and James Smith, d.b.a.

Jones-Smith Company, by John Jones, a partner."

Sole Ownership: If sole ownership, the Contractor should sign the Contract in the following manner:

"John Jones, Sole Owner."

Consider no proposal binding upon the City of Cincinnati until the execution of the Contract. Subject to the applicable provisions of law, the Contract shall be in full force and effect only from and after the date the City tenders or delivers a fully executed and approved counterpart thereof, or both, to the Contractor or the Contractor's duly authorized agent or representative.

103.07 Failure to Execute Contract. Add:

Failure to execute a Contract, for any reason, will be considered in the evaluation and award of future contracts.

104 Scope of Work

104.01 Intent of the Contract Documents. Add:

104.011 As Per Plan Designation. The absence of an "As Per Plan" designation on some or all item or items description(s) in the Contract Documents for which there are clear and controlling plan notes does not relieve the Contractor of the responsibility to read, bid and construct those particular items in accordance with the governing plan notes. Read or interpret the item descriptions in the bidding proposal with the governing plan notes and the ODOT CMS and the City Supplement. A claim based upon an "order of precedence" basis will be denied. Request clarification of conflicts, either real or perceived, between item descriptions and the governing plan notes through the pre-bid process.

104.02 Revisions to the Contract Documents.

B. Differing Site Conditions. Delete the wording, "as specified in 108.02 F" in the first paragraph.

Add:

The City will grant no adjustment for rock within six feet (1.8 m) of the surface before excavation.

In ascertaining whether subsurface conditions are unusual, infer that the Contractor has observed the local geology with the level of expertise described in the first paragraph of 108.05.

D. Significant Change in Character of the Work. Delete Section 2.

Add:

104.02 H. Quantity Overruns. Closely monitor Pay Item quantities as the work progresses. Obtain prior written authorization to exceed the Contract Amount for any Pay Item that might exceed the original Contract quantity. The City will pay for work completed and accepted in place at the original unit price up to the lesser of 110 percent of the original Contract quantity or the original Contract Pay Item extended total, plus \$5,000. The City will make no further payment for work performed above and beyond that amount unless the Contractor has obtained prior written approval.

Add:

104.031 Rights of Salvage Material Found. The City reserves ownership of all materials including but not limited to: old macadam stone, curbs, crosswalks, flagging, gutters, granite block and paving bricks. If the Special Provisions, the General Notes, or the Detailed Provisions of the Contract indicate that these items are to be salvaged, then excavate, segregate, clean, stack on pallets or other appropriate device and haul to a City Facility. Be careful not to damage the material.

If during the excavation the Contractor finds artifacts that the City wishes to salvage, City will notify the Contractor of such, and the Contractor will excavate, segregate, clean, stack on pallets and deliver to a City Facility. Any item of historical or archeological interest is also the property of the City, and the Contractor will protect and preserve as directed by the Engineer. Unless otherwise stated, compensation for this work will be per section 109.05.

104.04 Cleaning Up. Add:

As soon as portions of the work are ready for use, remove all dirt and rubbish, and clear all materials, forms, false work, temporary structures and equipment. Clean out all sewers, drains, inlets, manholes and other underground lines and structures built by the Contractor or affected by the Contractor's work.

During final cleanup, give special attention to cleaning out storm water inlet chambers. Remove all asphalt, concrete and other material deposited in the chamber or inlet connection. Remove and reinstall all manhole lids and inlet grates to ensure that none have been sealed to their frames.

104.05 Contractor Notification, Continuation of Work, Disputes and Claims.
This section has been moved to 108.02.G.

105 Control of Work

105.02 Plans and Working Drawings.

Add to the second paragraph:

Leave a 3-1/2 inch by 3-1/2 inch blank space for the review stamp next to the title block of all working drawings, unless otherwise directed by the Engineer.

Add:

105.021 Record Drawings/As-Built Drawings. Keep one complete set of plans and specifications at the site while working, designated 'Project Record Set.' Include all corrections, addenda, changes, revisions, notices and any other modifications. Submit the Project Record Set to the City after completion and before applying for final payment. Note all things exposed during construction, including utility locations, in the Project Record Set. Include in the Project Record Set all working drawings used during construction and any other catalog cuts or instructions needed.

In addition, engage the services of a Professional Surveyor, registered in the state of Ohio, to survey all new/revised/remodeled Stormwater Management Utility (SMU) facilities and create a record set especially for SMU consisting of as-constructed information drawn in red ink on mylar copies of the final set of plans. Provide the copy of the plans on mylar. Identify these drawings as intended for SMU and submit to SMU through the Contracting Agency. Include the Professional Surveyor's signed and sealed certification that the drawings represent the actual locations, elevations, etc. of the constructed facilities.

105.05 Cooperation by the Contractor. Delete the first paragraph and substitute:

The City will provide five sets of plans and specifications to the Contractor at no cost, unless otherwise indicated in the contract documents. It is the Contractor's responsibility to obtain the latest Standard Drawings referenced in the Plans or that are otherwise applicable.

Add:

105.071 Working Near Street Trees. Before commencing work when working within 15 feet (3.6 meters) of a tree, obtain a permit from the City's Urban Forestry Section. Contact them at 861-9070, 8:00 A.M. to 5:00 P.M., Monday through Friday.

Perform the work in such a manner as to minimize damage to existing street trees. The base of a public tree will not be cut more than necessary to accomplish the street rehabilitation work (the base being the first six inches (152 mm) above ground and the first three inches (76 mm) below ground).

Do not cut roots over 4-1/2 inches (114 mm) in diameter without a field inspection and written approval from an Urban Forestry representative. Where there is root cutting within 15 feet (3.6 meters) of a public tree, apply a high-phosphorus fertilizer in an attempt to repair the damage. Mix an appropriate product, similar to Mag-Amp or Super-Phosphate, into the backfill and apply it at a rate of six pounds (2.7 kg) per tree. The Engineer must approve the fertilizer used.

During the course of construction, protect branches extending over the street and sidewalk that are higher than 14 feet and 8 feet, (4.3 meters and 2.4 meters) respectively. The Contractor is responsible for any damaged or broken limbs, and bears the cost of any reasonable correction the Urban Forest Manager deems necessary.

Do not store any material or equipment in the sod area under or near existing trees. The Engineer shall give prior approval of an area before the Contractor uses it for the storage of any material or equipment.

In the event of failure to comply with the above procedures, the Contractor may assume liability for the affected tree as the law directs.

The City shall make no payment for the special requirements involved in "Working Near Street Trees"; therefore, include all costs under other bid items of the Contract.

Add:

105.072 Loop Detectors. The work may affect traffic loop detectors at various locations. Exercise extreme care when working in an area containing detectors.

The City and Contractor shall inspect the signalized intersections prior to the start of work to locate detectors and determine whether or not the detector can be salvaged.

If the City and Contractor determine that the detector must be removed, the City of Cincinnati Traffic Engineering forces will install a new detector. Coordinate the Contractor's operations with the City forces to reduce the out-of-service time of the detector. Contact Traffic Engineering at 352-5272 to coordinate these activities. Installation of new loop detectors will involve no cost to the Contractor. The City will grant no additional compensation to the Contractor for complying with this provision or any other rearrangement of work involving loop detectors.

The City may assess against and back-charge against the Contract or permit for any damage to loop detectors the Contractor causes.

105.08 Cooperation Between Contractors.

Add:

If the bid documents call for assignment of Subcontractors, execute pertinent agreements needed to consummate assignments.

105.15 Failure to Maintain Roadway or Structure.

Add:

In addition, if the conditions constitute a hazard to the public, the City may, without notice to the Contractor, take measures it deems appropriate to mitigate the hazard and charge the Contractor all associated costs. The Contractor may not make a claim for damages in these circumstances.

105.16 Borrow and Waste Areas.

Add at the end of the second paragraph:

Materials deposited off-site without the required approvals may be ordered removed and properly disposed of without additional compensation.

| Add at the end of the fifth paragraph:

Apply, pay for and obtain all required permits, including cut/fill permits.

| Add at the end of the ninth paragraph:

Provide written certification at completion of restoration that the off-site material disposal area(s) has been restored to the property owner's satisfaction, and that all required permits have been applied for, obtained, paid for and properly closed out.

105.17 Construction and Demolition Debris.

Add at the end of the fourth paragraph:

Unless the Contract Documents provide otherwise, the City bears all costs for analysis and disposal of any contaminated materials the Contractor encounters during the work. Cooperate with the City if such material is encountered.

Add:

| **105.20 Construction Stakes, Lines and Grade.** Unless otherwise noted in the Plans or Special Provisions, and except as described below, the City Surveyor will set all line, grade, slope and location stakes necessary for the proper prosecution of the work. The City Surveyor will perform layout work during regular business hours only, Monday through Friday, 7:30 A.M. to 4:00 P.M.; adjust scheduled work accordingly. Notify the Engineer at least two regular business days in advance prior to needing layout for construction purposes, and furnish at the Contractor's own expense all stakes, spray paint and "PK" nails necessary for their placement. Provide proper staking materials as required by the Engineer, which could include Grade Oak Stakes, Pine Guard Stakes and Slope Stakes.

| Preserve all monuments, witnesses, stakes, paint marks and other construction control. If the Contractor carelessly or needlessly destroys any of the stakes or markings, the City shall charge the cost of replacing them against the Contractor and deduct such amounts from payments due to the Contractor. Provide any cleaning or traffic control as may be required by the City Surveyor in order to perform such layout. Review line, grade, and elevation stakes placed. Immediately notify the Engineer of any conflicts or possible errors.

| Construct the work in strict accordance with the City Surveyor's stakes and paint marks, and take full responsibility for conformity and agreement of the work with the stakes and paint marks as originally set by the City Surveyor.

Unless noted otherwise, the Contractor's costs associated with this item are considered incidental to the completion of the other items of work, and separate payment for these costs will not be made.

The City Surveyor will not perform any as-built or as-constructed measurements or surveys, or any existing conditions surveys or confirmation-type measurements or surveys for any purpose. Unless explicitly noted otherwise in the Plans or Special Provisions, any surveying, layout, or measuring necessary to correctly fabricate and/or set in place railings of any nature, embedded items (including anchor bolts), bearings, sleeves, inserts, drainage systems, piping runs or hangers/anchorage, ladders, platforms, expansion joint assemblies or covers, signs or signposts, etc., are the responsibility of the Contractor.

106 Control of Material

106.02 Samples, Tests, and Cited Specifications.

Delete this section and substitute:

All materials must conform to work requirements. The Contractor has the obligation to demonstrate material conformance to work requirements.

All materials are subject to sampling, inspection and testing. Provide and deliver, at no expense to the City, any samples needed for testing. Include samples in the work if suitable and applicable.

Submit Certification of Material Compliance for any material before incorporating in the work. Such certification shall include, at a minimum, the following:

- A. Project Name
- B. Material Description and Quantity
- C. Material Supplier Including Address, Phone Number and Contact
- D. Intended Use of the Material
- E. Location and Date of Material Production
- F. Applicable Standards, Tests, and Results Thereof
- G. Statements Declaring the Material Conforms to the Contract Requirements

The costs to supply such Certificates are incidental to Contract items.

Unless otherwise stated, the City will pay for all on site testing on Public Improvement Contracts. The Contractor will bear all costs, including the City's administrative costs, associated with retesting any material that does not initially meet Contract requirements. Upon request to the Engineer, the City will provide the Contractor with copies of any test results.

106.03 Small Quantities and Materials for Temporary Application.

Delete this section.

106.08 Department- Furnished Material.

Delete this section and substitute:

Furnish all materials required to complete the work except as otherwise provided.

The City will make City-furnished material available to the Contractor for pickup at a City facility or some other place within the metropolitan area.

Unless otherwise specified in the Contract, the costs of handling, hauling and placing all materials after they are received are included in the Contract price for the item in connection with which they are used.

106.09 Steel and Iron Products Made in United States.

Add:

This section only applies to Contracts partially or wholly funded with State and/or Federal money.

107 Legal Relations and Responsibility to Public

107.02 Permits, Licenses and Taxes.

Add:

If the Contractor desires to use water from fire hydrants during construction, obtain a permit for the use of the hydrant from Greater Cincinnati Water Works, 4747 Spring Grove Avenue. Show these permits to the Engineer before using the hydrants. The Contractor must pay Greater Cincinnati Water Works for the water so used before the City releases the Contractor's final payment.

All Contractors working within the Right-of-Way must apply for and secure a permit from the Cincinnati Department of Transportation and Engineering before starting work, unless previously obtained by the Contracting agency. If the work is under Contract with the City, there will be no cost for this permit. Any Inspector may order suspension of any unpermitted work without additional compensation to the Contractor.

107.04 Restoration of Surfaces Opened by Permit.

Delete this section and substitute:

Make utility connection to all lots before Contractor places any permanent pavement, for all new subdivisions and developments the City intends to accept in the future.

Perform restoration of any street cut in accordance with the Contract provisions and the Department of Transportation's "Street Restoration Book", latest edition.

Add:

107.041 Restoration of Surfaces Opened for Water Main Work. Contractor expressly understands and agrees that the unit prices bid on the various items in the Proposal includes all costs and charges for the restoration of street-paving, sidewalks, or other areas opened or disturbed in the pursuance of water main work in accordance with the Plans.

Perform all restoration in a neat and professional manner. Before the City makes final payment under this Contract, the representative of the political subdivision having jurisdiction must accept the final restored surfaces. All restoration shall conform to the following:

A. Within Corporate Limits of Cincinnati. Restoration in the streets and highways of the City of Cincinnati must conform to all of the rules and specifications as described in City Supplement **107.04**.

B. Outside the Corporate Limits of the City of Cincinnati but within Hamilton County. All restoration within this area must conform to the State of Ohio, Department of Transportation, "Construction and Material Specifications" the requirements of Hamilton County Engineer's Office or that of the appropriate agency of jurisdiction, and GCWW Standard Drawings pertaining to street restoration.

C. Special Restoration. In those cases where restoration differs from the above stated specifications, the required restoration will be detailed on the Plans and will be so noted on the Special Provisions.

107.07 Public Convenience and Safety.

Add:

Conduct the work safely and assure a safe work site. The Contractor is responsible for the safety of the Contractor's employees, agents and subcontractors, City personnel and all other personnel or persons at the work site. The Contractor is responsible for the adequacy and safety of all construction methods or procedures and the safe prosecution of the work.

Add:

107.071 Site Safety Plan. File with the Engineer prior to start of work a Site Safety Plan, which at a minimum:

A. Lists key personnel and alternates responsible for site safety along with means of contacting these personnel at all times.

- B. Names one person as a Competent Person responsible for site safety activities and includes a resume of their qualifications to be a Competent Person.
- C. Describes the risks associated with each operation conducted.
- D. Confirms that personnel are adequately trained to perform their job responsibilities and to handle the specified hazardous situations they may encounter.
- E. Describes the protective clothing and equipment personnel will wear during various site operations.
- F. Describes any site-specific medical surveillance requirements (hazardous waste or material sites only).
- G. Describes the program for periodic air monitoring, personnel monitoring, and environmental sampling, if needed (hazardous waste or material sites only).
- H. Describes the actions to be taken to mitigate existing hazards (e.g., containment of contaminated materials) to render the work environment less hazardous.
- I. Defines site control measures and includes a site map.
- J. Establishes decontamination procedures for personnel and equipment (hazardous waste or material sites only).
- K. Sets forth a Contingency Plan for safe and effective response to emergencies.
- L. Sets forth the site's Standard Operating Procedures (SOPS). SOPS are those standardized activities that use a checklist. The procedures should be:
 1. Prepared in advance.
 2. Based on the best available information, operational principles, and technical guidance.
 3. Field-tested by qualified health and safety professionals and revised as appropriate.
 4. Appropriate to the types of risk at that site.
 5. Formulated to be easy to understand and practice.
 6. Provided in writing to all site personnel who should be briefed on their use.
 7. Included in training programs for site personnel.

Display a copy of the Site Safety Plan at the work site at all times.

In addition, supply to the Engineer any safety information or documentation that the state or federal agency requires under law.

Add the following:

107.072 Securing Excavated Areas within the Public Right-of-Way

Excavations within the public right-of-way are necessary to perform a wide variety of important work. Recognizing that any work within the right-of-way poses increased risk to workers and travelers alike and that this work disrupts public use and enjoyment of this space, Contractors' performing work within the public right-of-way must take all necessary steps to ensure public safety and minimize the duration of their work. As a minimum, contractors' performing work within the public right-of-way must take the following measures:

A. Excavations within Roadway Areas

Secure excavations within the roadway area at all times in accordance with an approved maintenance of traffic plan. To promote public safety, the contractor shall provide, install, and maintain at all times, all necessary traffic control devices needed to ensure that traffic is safely detoured around the work area. Unless otherwise permitted, the excavation shall be properly covered with steel plating when not attended.

B. Excavations within the Sidewalk Space (Sidewalk space is defined as public space between the edge of pavement and the right-of-way line).

1. Maintain pedestrian protection and pedestrian access at all times in accordance with City Supplement Section 614.07.

2. If possible, all excavations shall be covered with a steel plate or approved equal to provide a safe, walkable, skid-proof surface. Asphalt wedges may be required along edges of plates to prevent tripping hazards.

3. Secure the entire perimeter of the work area (at least one foot beyond the limits of excavation) with rigid barrier such as plastic mesh fencing (minimum of 3' high) mounted on weighted drums or fence posts with Sidewalk Closed Sign at each end.

C. Temporary sidewalk restoration

Sidewalks may be temporarily restored with asphalt and opened to pedestrians if constructed in accordance with the Street Restoration Manual, Permit, or Contract requirements.

107.09 Use of Explosives.

Delete this section and substitute:

The Director of DOTE will not permit blasting or the use of explosives on the work without written authorization from the City Manager. Fill out an "Application for Blasting Permit" from the Office of the City Engineer, Room 450, City Hall. The City Engineer will review and make recommendations to the Director. Make this application well in advance of proposed blasting operations (at least one week) to allow ample time for the necessary investigation. If the City grants permission for blasting, conduct the operations in strict accordance with the

regulations attached to the "Application for Blasting Permit" and additional regulations specified herein.

Use, handle, store, and transport explosives in conformance with all applicable requirements.

107.12 Responsibility for Damage Claims and Liability Insurance.

Add:

Furnish two unaltered copies of the official certificate of the Industrial Commission of Ohio indicating that the Contractor has paid the premiums required under the Ohio Workers Compensation Act. Furnish Ohio Industrial Commission approval as such if self-insured.

Before any work embodied in the Contract will be permitted to be performed, furnish two copies of a certificate of insurance naming the City of Cincinnati as an additional insured, as evidence that the Contractor has procured comprehensive general liability insurance. Such policy shall include the following types of insurance: Comprehensive form; premises - operations; products completed operations; contractual; broad form property damage; independent contractors; and personal injury. The standard general liability coverage for damages due to explosion, collapse, and underground property damage shall not be deleted by exclusion endorsements. Maintain such insurance coverage in not less than the following amounts: Combined single limit for bodily injury and property damage of \$1,000,000 per occurrence/\$2,000,000 aggregate. The Contractor may obtain required coverage through primary insurance or any combination of primary and umbrella insurance. In addition, the general aggregate limit shall be required on a per project basis.

The Contractor may provide insurance coverage for Subcontractors, furnishing riders to the Contractor's own general liability policy, or the Subcontractor may procure the Subcontractor's own insurance.

When the work involves the operation of trucks and/or automobiles, the Contractor must provide comprehensive automobile liability insurance with a minimum combined single limit for bodily injury and property damage of \$1,000,000 per occurrence. Include an "All Risk" Builder's Risk policy in the Contractor's required insurance which shall provide Fire and Extended Coverage, Vandalism and Malicious Mischief coverage for an amount equal to one hundred percent (100%) of the completed value of the entire project and written in the Owner's and Contractor's name. Keep such insurance in full force and effect until all work is completed and accepted by the City of Cincinnati.

In addition to the above insurance requirements, furnish, when applicable, Railroad Protective Liability and property damage liability insurance in the amount the affected Railroad requires and in accordance with the Railroad Liability Form the Federal Highway Administration prescribes in Policy and Procedure Memorandum 20-12 as amended. In addition to the above insurance requirements, provide insurance of the type and in the amounts stated above, covering the Contractor's liability under 107.12, with the City of Cincinnati as the named insured.

To be acceptable, all insurance policies must be underwritten by a company authorized to do business in the State of Ohio, having a Best's Financial Rating of Class IX or better and a Policy Holder's Rating of "A" or better.

All proof of insurance submitted to the City shall clearly set forth all exclusions and deductible clauses. The Contractor is responsible for the deductible limit of the policy and all exclusions consistent with the risks the Contractor assumes under this Contract and as imposed by law. The City's Purchasing Agent may set maximum reasonable deductible limits.

In the event that the Contractor's insurance coverage is valid for a period of time less than the period of the Contract, the Contractor must renew his insurance policies as necessary and provide new certificates of insurance to the City.

All of the insurance referred to above shall be subject to the approval of the City. Keep such insurance in full force and effect until all work is fully completed and the City of Cincinnati has accepted it.

107.13 Reporting, Investigating, and Resolving Motorist Damage Claims.

Substitute:

"Engineer" for District's Construction Office and Department's Court of Claim Coordinator.

107.19 Environmental Protection.

Delete the second paragraph including parts A, B, C, and D.

107.21 Prompt Payment.

Delete this section and substitute:

This section shall apply to and govern the payment process for all subcontractors:

- A. Except as otherwise provided in Sections 1311.25 through 1311.32 of the Ohio Revised Code, or any successor statute, contractors that engage subcontractors to perform part of the work on a contract with the City shall pay subcontractors for satisfactory work in a timely fashion. A payment is timely if it is mailed, delivered or transferred to the subcontractor no later than ten (10) days after the contractor's receipt of any payment from the City.
- B. If a subcontractor is not paid in a timely fashion, the contractor shall pay interest on the balance due from the eleventh (11th) day after the contractor's receipt of any payment from the City, at the rate specified per Cincinnati Municipal Code, unless a bona fide dispute exists between the contractor and such subcontractor.
- C. Subcontractors receiving payment as described herein shall pay their subcontractors, and be liable for interest on late payments, in the same manner as contractors are required to

pay subcontractors in this section.

D. All contractors shall promptly render payment to all subcontractors on a contract. Each contractor shall provide with each invoice to the City on each contract, beginning with the second invoice, proof of payment to subcontractors, in form and content approved by the Director of Finance, evidencing that all subcontractors have been duly paid out of the proceeds of the contractor's payments from the City under the contract, unless a bona fide dispute, documented in writing exists between the contractor and the unpaid subcontractor.

E. Notwithstanding the payment procedure otherwise set out in [Section 319-7](#) of the Cincinnati Municipal Code, or the provisions of any definition contained in this chapter, the processing of final pay requests on construction, reconstruction and remodeling projects shall be as follows:

1. Time elapsed awaiting receipt by the City of a final release from a contractor with respect to a final payment, time elapsed in publication for and holding of final settlement pursuant to Sections 1311.25 through 1311.32 of the Ohio Revised Code or successor statute or time elapsed in the expending authority's or director of finance's seeking of legal advice or guidance from the department of Law shall not count in the calculation of the interest accrual date as set out herein. Receipt by the expending authority of a final payment request invoice with all other conditions precedent required by the definition of complete and responsive invoice satisfied and an invoice date stated will commence the interest accrual date for a final payment based on the invoice date. With the exception of those steps set out in subsection (2) hereof, and except as provided in [Section 319-19](#) of the Cincinnati Municipal Code, all steps necessary to process a final payment, subsequent to the receipt by the expending authority of the complete and responsive invoice for such final payment, shall count as part of the interest accrual date calculation.

2. With respect to the tolling of the interest accrual date calculation for such final payment, the time elapsed in publishing for and holding final settlement pursuant to Sections 1311.25 through 1311.32 of the Ohio Revised Code or successor statute, the time elapsed from the tender by the City to the contractor of a final release on the final payment until the return of such release to the expending authority, and the time elapsed in the expending authority's or Director of Finance's seeking of legal advice or guidance from the department of Law shall not count in the calculation of the interest accrual date as set out herein

Add:

107.22 Notification to Affected Parties.

Notify adjacent, abutting, nearby and affected persons, businesses and individuals of upcoming construction activities. Such notices may include attendance at neighborhood or

community meetings, preparation, reproduction and distribution of flyers, and explanations to residents or passersby. Provide notice at least 48 hours before and as far in advance of the anticipated work as possible with due recognition of uncertainties of weather, production, and level of disruption. Conditions may require renotification.

Give to the Engineer for review, a draft copy of any written notice the Contractor prepares. Include in all such written notices a statement describing the work, identifying the disruption, stating the approximate duration and providing information relating that the work is being performed under a City Contract and to which City office the citizen may address concerns. The Engineer may direct the Contractor to print this notice on City letterhead. Use the construction company's name and telephone number on the notice.

Provide and maintain driveways and pedestrian ways to abutting properties in a safe condition. Cooperate with the affected business operators and property owners in every practical way in order to minimize disruption to their operations. Notify residents and businesses at least 24 hours in advance of when their driveways will be blocked during construction.

108 Prosecution and Progress

108.01 Subletting of Contract. Delete this section and substitute:

Within two weeks after the award of a Contract, send to the Engineer a complete list of any Subcontractors the Contractor plans to use to complete the work, along with completed Subcontractor Approval Form Purch 2004. Submit for approval any deviations and reason for the change that may occur during the term of the Contract. Failure to submit a complete list of subcontractors is reason to withhold future pay applications.

The City shall promptly notify the Contractor in writing if the City or the Engineer, after due investigation, has reasonable objection to and does not approve any Subcontractor. Do not enter into a Subcontract until after the City approves the Subcontractors by use of form Purch 2004.

Rental of equipment, either with or without an operator in connection with the performance of the Work under this Contract, shall not be considered subcontracting if the Contractor maintains full supervision and control over its operation and the operator's wages.

Whether the Contractor sublets or hires equipment under this Contract, the Contractor is responsible to fulfill all the terms of the Contract and provide satisfactory evidence that the prevailing wage rates are being paid to all personnel engaged on the site, whether the Contractor's own, those of a Subcontractor, or anyone directly or indirectly employed by either the Contractor or Subcontractor.

108.02 Partnering Delete the first paragraph.

108.02.B. Initial Partnering Session. Delete this section.

108.02.C. Progress Meetings. Delete the last sentence of this section.

108.02.D. Post-milestone Meeting. Delete this section.

108.02.E. Partnering Monitoring. Delete this section.

108.02.G. Dispute Resolution and Administrative Claims Process. Delete this section and substitute the following:

1. General. Follow this process in order to resolve disputes on the project and to seek additional compensation and/or Contract time from the City in the form of an administrative claim.

2. Process. Exhaust this process prior to filing an action in the Ohio Court of Claims. These procedures do not compromise the Contractor's right to seek relief in the Ohio Court of Claims. File a complaint in the Ohio Court of Claims within 60 days after the completion of all extra-judicial dispute resolution requirements if the claim is not resolved.

3. Issues Covered. Disputes will include disagreements, matters in question, and differences of opinion between City personnel and the Contractor. Claims are disputes that are not settled in the dispute resolution process for which the Contractor has documented costs or time incurred as a result of such disputes.

Disputes and claims by subcontractors and suppliers may be pursued by the Contractor on behalf of subcontractors or suppliers. Disputes and claims of subcontractors and suppliers against the Contractor will not be reviewed by the City. Disputes and claims by subcontractors and suppliers against the City but not supported by the Contractor will not be reviewed by the City.

Disputes and claims subject to review by the City include:

- A. Interpretation of specifications, standard drawings, plans, the proposal, working drawings, change orders, and orders by City personnel having authority over the project.
- B. Differing site conditions as defined in 104.02 B.
- C. Cost and time incurred by:
 - 1. Suspension of the work under 104.02 C.
 - 2. Significant changes in scope of work under 104.02 D.
 - 3. Utility interference with the work under 105.07 and 4A notes.
 - 4. Extra work ordered under 104.02.
 - 5. Acts or inaction of the City or other government agencies.
- D. Adequacy and constructability of the plan design.
- E. Contract time extensions due to weather, shortages of labor, equipment or materials, or other causes beyond the Contractor's control.

F. Other subjects mutually agreed upon by the City and Contractor to be under the scope of the dispute resolution and claims process.

4. Early Notice Required. Give written notice of any circumstance or dispute on the project that may result in a claim. Give early notice by the end of the second working day following the discovery of the occurrence of the circumstance or dispute. Maintain records on the Superintendent's daily report of the additional labor, equipment, and materials used on the disputed work or made necessary by the circumstance. Begin record keeping when the project personnel are aware of the circumstance or dispute. Submit these records on a weekly basis. Failure to give early notice or keep and submit cost records will be a sufficient reason for the City to deny the claim.

5. Continuation of Work. Continue with all project work, including that which is in dispute. The City will continue payments for Contract work.

6. Process Steps in Detail. All parties in the dispute must follow the specified steps. Personnel involved in second or third tier review will not consider a dispute until it has been properly reviewed by the previous tier. Do not contact City personnel involved in a second or third tier review until the dispute has been thoroughly reviewed by the previous tier.

a. Step 1 of Dispute Resolution (Project Level). The Construction Engineer will meet with the Contractor's Superintendent within two working days of receipt of any early notice. They shall review all pertinent information and Contract provisions and negotiate an equitable settlement according to the Contract Documents. If settlement is not achieved, the dispute is moved to Step 2.

b. Step 2 of Dispute Resolution (Principal Engineer Level). If the dispute is not resolved in Step 1, request a meeting with the Principal Construction Engineer within five working days of completion of Step 1. Personnel from the Contractor's headquarters and the Principal Construction Engineer shall meet to consider the dispute. The City and Contractor's personnel shall review the information on the dispute presented by the personnel involved in Step 1 and negotiate an equitable settlement according to the Contract Documents. If settlement is not achieved, the dispute is moved to Step 3.

c. Step 3 of Dispute Resolution (City Engineer/Chief Engineer Level). Send the City/Chief Engineer a *Notice of Intent to File a Certified Claim* within 14 calendar days of the completion of Step 2. State in the notice the Contractor's request for a hearing on the claim or for an acceptable alternative dispute resolution technique. Provide documentation as required in 110.07. Certify the claim, under oath, in writing. Attest to the following in the certification:

1. The claim is made in good faith.
2. To the best of the Contractor's knowledge, all data offered to support the claim is accurate and complete.
3. The claim amount accurately reflects the Contractor's actual incurred costs.

Notarize the claim certification, pursuant to the laws of the State of Ohio. The following is an example of the correct form for a claim certification:

(The Contractor) certifies that this claim is made in good faith, that all supporting data is accurate and complete to the best of (the Contractor's) knowledge and belief, and that the claim amount accurately reflects the Contract adjustment for which (the Contractor) believes the City of Cincinnati is liable.

(The Contractor)

By: _____

(Name and Title)

Date of Execution: _____

The City Engineer/Chief Engineer will schedule a hearing on the dispute within 15 working days of receiving a certified claim and acceptable dispute documentation, or as otherwise agreed to by the City Engineer/Chief Engineer and the Contractor. The Contractor's position on the dispute will be presented by executive officers of the Contractor (maximum three). The Principal Engineer will present the reasons the dispute was not resolved. The City Engineer/Chief Engineer will issue a written decision on the dispute within 15 working days of the hearing.

The City shall pay interest on any amount found due on a claim that is not paid within 30 days of the City's receipt of the certified claim. Such interest shall be paid to the Contractor for the period beginning on the thirty-first day after the City's receipt of the certified claim, and ending on the day that the payment of the amount due is made. Interest payments provided for in this provision shall be at the rate per calendar month that equals one-twelfth of the rate per annum prescribed by section 5703.47 of the *Ohio Revised Code* for the calendar year that includes the month for which the interest charge accrues.

7. Claim Documentation Requirements. Provide an original dispute document that clearly and in detail gives the following information for each item of additional compensation and time extension requested:

- A. A narrative of the disputed work or project circumstances at issue, with sufficient description and information to enable understanding by a third person who is not familiar with the project. Include the dates of the disputed work and the date of early notice.
- B. References to the applicable provisions of the plans, specifications, proposal, or other Contract Documents. Include copies of the chief provisions in the claim documents.
- C. The dollar amount of additional compensation and length of Contract time extension being requested.
- D. The cost and schedule analysis and supporting documents that were the basis for the requested compensation and time extensions stated in 3 (above).

- E. Copies of relevant correspondence and other pertinent documents.

Identify the dispute document by Contract Number, Contractor name, Subcontractor, or Supplier (if involved in the dispute), and dispute number.

8. Alternative Dispute Resolution (ADR). The Contractor may request ADR in lieu of filing action in a court of claims. The City may agree to arbitration or mediation in the manner in which those methods are practiced by the City and allowed by law.

The City will coordinate the following: the agreement of the parties to the ADR method; the selection of a neutral third party or technical expert; and the equal sharing of the fees of the neutral third party or technical expert. The City will obtain a written agreement, signed by both parties, that establishes the ADR. The neutral third party or technical expert will have complete control of the claim upon execution of the ADR agreement.

9. Agency(ies) Excluded from This Section's Provisions. The provisions of this section (Section 110 – Dispute Resolution and Administrative Claim Process) shall not apply to contracts let by GCWW. The provisions shall apply, however, to GCWW pay or Contract items included in Contracts let by other agencies.

108.02.H. Post Construction Meeting. Delete this section and substitute:

After final inspection, the Engineer may conduct a meeting to critique the Contract Documents (i.e., plans, proposal). The meeting will be at a time and place as determined by the Engineer. The Contractor may be asked to participate. The cost to attend this meeting is incidental to other Contract items.

108.02.I. Partnering Close-Out Survey. Delete this section.

108.03.A.4 Recovery Schedule.

Add:

No time extension will be considered without timely submittals of all schedules and updates. A request for any time extension must identify all delays (excusable and non-excusable) a description of the delay, the reason for the delay and the impact on the schedule.

108.06 Determining a Time Extension to the Completion Date and Payment for Excusable Delays.

- A. General. Delete the reference to 108.02.F in the third paragraph and replace with 108.02.G.

108.10 Payroll Records.

Add:

At any time during the Contract period, the City may require the Contractor and/or its Subcontractor to submit a Form 104 or Form 104F and Form 66 certifying that wages have been paid in accordance with the Prevailing Rate of Wages provisions set forth in the Contract.

Each month during the Contract period, submit a form **PURCH 257**, Monthly Employment Utilization Report.

109 Acceptance, Measurement and Payment

109.01 Measurement of Quantities.

Add:

For Lump Sum Items, the Engineer may request a schedule of values allocated to various portions of the Work, prepared in such form and supported by such data to substantiate its accuracy as the Engineer may require. Unless the Engineer objects, this schedule shall be used as a basis for reviewing the Contractor's Applications for Payment.

109.05.C.5. Foreman's Transportation. Delete this section and substitute:

The City will pay \$5.00/hour for the foreman/tool truck.

109.05.C.6 Subcontract Work. Delete the first sentence of the first paragraph Use a 5% mark-up of the subcontractor force account cost for administrative cost.

109.05.C.8. Trucking

Delete first paragraph and substitute the following: Trucking firms and owner operators not subject to prevailing wage, will be paid invoice cost plus 5% for administrative cost

109.05.C.9. Professional and Specialized Work

Delete first paragraph and substitute the following:

The following work, when performed by a firm hired by the Contractor, is paid at the reasonable and fair market invoiced cost plus 5% for administrative cost

109.05.C.10. Payment for Force Account Work

Change the reference to "108.06.G" in the last sentence of section "b" to 108.02G.

109.05.D.2.f Home Office Overhead.

Delete the first four paragraphs. Add:

The City will only pay for the Contractor's home office overhead if all work on the project is suspended at no fault of the Contractor, the length of the suspension is unknown, the

Contractor's crews are put on standby, and the Contractor cannot get replacement work for the time period of the suspension.

Add:

109.051 Contract Contingency. This item is used to cover changes or additions for work directly relevant to completing the original Contract; initial estimated quantities do not include the item. The Engineer must approve, in writing, all expenditures against this item. The Engineer and Contractor must agree on lump sum or unit price or an authorization to proceed under Force Account before Contractor starts work. Force Account authorization must include an estimate to complete the work.

109.09 Estimates.

Add:

As a rule, the City will make no monthly payment for an amount less than \$500.00.

The City may reduce or entirely withhold partial payments if, in the opinion of the Engineer, construction is not proceeding according to the Contract, or for any other violation of the Contract, or for failure of the Contractor to comply with orders of the Engineer or pending settlement of claims or liens filed against the Contractor.

The City will pay not less than 92 percent of the estimates until 50 percent of the Work is completed, thereafter 100 percent of the estimates submitted by the Contractor and approved by the City will be paid.

Make payment requests on Contractor's invoice, form and content to be approved by the Contract Administering Agency. Submit Form No. 97S, Affidavit of General or Mechanical Branch Contractor, with every request for partial payment. Supply of forms is available from the Contract Administering agency.

109.10 Payment for Delivered Materials.

Add:

City will process no subsequent payments for construction work, up to the value of the stored material allowance, until such time that the Contractor submits an affidavit from the Supplier indicating payment was received.

109.12 Final Acceptance. Delete this section and substitute:

A. Substantial Completion: Substantial completion occurs when the City receives intended use of the project. Notify the City Project Engineer when the Contractor believes he has substantially completed the work. City shall respond to Contractor's notice, within ten days, of its acceptance or rejection of the Contractor's claim of substantial completion. Liquidated damages will not accrue beyond the date of substantial completion.

Contractor's maintenance responsibilities as noted in Section 105.14 end on the Substantial Completion date.

B. Punch list: Upon substantial completion, the Engineer will issue to the Contractor a written punch list of minor work required as a condition of final acceptance. The Engineer's punch list will stipulate a reasonable time, if different than 30 days, to complete the required work. **Failure of the Contractor to complete the punch list items by the stipulated term, normally 30 days, will result in an administrative fee of \$100 per calendar day for every day beyond the stipulated time period the punch list work remains incomplete.**

C. Final Inspection: Notify the Engineer when the Contractor entirely completes work and all of the Engineer's punch list items are complete including the final cleaning up and removal of all project signs. The Engineer will inspect the improvement within ten business days. If items remain which the Contractor must complete or remedy, perform the work immediately. When the Contractor corrects such items, the City will make final inspection. The work must pass final inspection before the City will accept it.

Upon final inspection and acceptance and receipt of record drawings, the Engineer will issue a certification stating that, to the best of the Engineer's knowledge, information and belief, and on the basis of the Engineer's observations and inspections, the Work has been completed in accordance with terms and conditions of the Contract Documents, and will establish and notify the Contractor of the Final Completion date. The one-year repair and correction period will commence on the Final Completion date.

D. Correction and Repair Period: Remove, replace and/or repair at the Contractor's own expense and at the convenience of the City, any faulty, defective or improper work, materials or equipment discovered within one year from the date of Final Completion or for such longer period as the Contract Document may provide. Complete this correction and repair work within 30 days of the notification of faulty, defective or improper work.

The bond securing the Contract shall cover this one-year period.

Bear the cost of making good all work of separate Contractors destroyed or damaged by such correction.

Be responsible for handling replacement and installation of malfunctioning equipment and materials during the entire period that the equipment or material is covered by this Correction or Repair Period or the Manufacturer's guarantee, or any guarantees specified elsewhere in the Contract Documents, whichever is longer. This requirement includes delivery and installation of replacement equipment.

E. Finalization: Accept the final quantities as determined by the Engineer or provide a written notice indicating the reason for disagreement within 30 Calendar Days of receiving the Engineer's list of final quantities. If the City receives no notice of disagreement, then the final payment will be based on the Engineer's list of final quantities.

If the Contractor erroneously overestimates any items in any partial payment estimate, Contractor must correct such error in the statement of total cost, and the Contractor shall have

no right to any such excess and shall not be entitled to any damage on account of such correction in the statement of total cost.

Supply all documents necessary for Project finalization within 60 Calendar Days from the Final Completion. These documents include:

1. Delinquent material certification.
2. Delinquent certified payrolls or required revised payrolls and utilization reports.
3. Warranties, operating/maintenance manuals and equipment list.
4. Completed form FHWA 47 on Federal-Aid projects over \$1,000,000 that are on the National Highway System, excluding beautification and railroad protective device projects (unless otherwise directed by the Engineer).
5. Agreement as to final quantities, including any delinquent force account records.
6. Form 66, from all Contractors and Subcontractors certifying that all payments have been made for all labor, material, equipment, and subcontracts. Material certificates from all material suppliers stating they have been paid in full.
7. Form 104 or Form 104F, from all Contractors and Subcontractors certifying that wages have been paid in accordance with the Prevailing Wages provisions set forth in the Contract.
8. Consent of Surety to Release Final Payment.
9. Any other documents the City deems necessary.

Failure to submit these acceptable completed documents will result in an administrative fee of \$100 per Calendar Day for every day that any of the required documents remain delinquent, starting 30 Calendar Days after receipt of written notification, from the Engineer, of a document deficiency.

F. Final Payment: City will make final payment after the Contractor achieves Final Completion and upon receipt of all Project Finalization Documents, and Contractor's Final Invoice.

G. Termination of City's Responsibility: No person, partnership, firm or corporation other than the Contractor shall have any interest in the Contract, and no claim shall be made or held valid, and neither the City nor its agents shall be held liable for, nor shall be held to pay any money except as herein provided. The acceptance by the Contractor of the final payment made as aforesaid shall operate as, and shall constitute, a release to the City and its agents from any claim or liability to the Contractor for anything done or furnished for, or relating to the work, or for any act or neglect of the City or any person related to or connected with the work.

The Contractor further agrees to relieve and hereby relieves and indemnifies and holds harmless the City from and against any and all liabilities, losses, judgments and claims of every nature and description by or on behalf of any person, firm, corporation, or other entity or governmental authority arising out of the performance of this Contract by said Contractor, the Contractor's officers, employees or agents.

The Contractor hereby relieves and indemnifies and holds harmless the City, its officers, employees, agents and servants from and against any claim or liability arising out of, from or

based on the violation of any law, statute, ordinance or regulation by the Contractor, the Contractor's officers, servants, employees, or agents.

The Contractor indemnifies, protects, defends and saves the City harmless from all liabilities, judgments, costs, damages and expenses, which may in any way come against the City by reason of the use of any patented material, machinery, device, equipment or process the Contractor furnishes or uses in the performance of the work under the Contract, or by reason of the use of a patented design the Contractor furnishes and installs in the work.

In the event any claim, suit, or action at law, or inequity, of any kind whatsoever is made or brought against the City, the City shall have the right to retain from the money due or to become due to the Contractor any amount of money sufficient to protect itself against loss or judgment in the manner and upon the conditions as herein specified.

The Contractor pays all damages to real or personal property, or for any injury sustained by any person growing out of any act or deed of the Contractor, or the Contractor's agents and employees, that is in the nature of a legal liability, and protects and saves the City harmless against all suits and actions of every name and description brought against the City for, or on account of, any such injuries sustained by any person or persons caused by the Contractor, the Contractor's agents and employees in the execution of the work, or by or in consequence of any negligence in guarding the same, or by or on account of any omission or act of the Contractor, the Contractor's agents or employees, and the City will retain so much of the money due the Contractor under and by virtue of the Contract, as may be considered necessary to protect itself against loss and judgment until such suit or claim for damage shall have been settled, and the Contractor furnishes to the City satisfactory evidence to that effect.

200 EARTHWORK

Item 201 Clearing and Grubbing

Add:

201.021 Inspection by Tree Professional.

A Forester or Arborist will inspect any tree the Engineer deems should not be removed during the work to determine its relative structural safety and potential chances of surviving three years after this earthwork. Treat any tree that the Forester or Arborist concludes is safe and likely to survive in accordance with the standards specified in Item 666. The treatment designated by the Forester or Arborist is not a guarantee that the tree will survive but is a precaution to help it survive the Earthwork.

201.03 Clearing and Grubbing.

Add to the second to last paragraph:

Prune branches of trees extending over the roadbed in accordance with the standards specified in 666.03 and 666.04.

Item 202 Removal of Structures and Obstructions

202.02 General Construction Requirements.

Add to first paragraph:

Remove all abandoned utility service boxes (curb or roadway) to one foot (305 mm) below the existing surface. Restore disturbed pavement, walk, driveway or sod so it conforms to adjacent surface(s). Replace disturbed concrete walk and/or driveway from joint to joint. Remove existing street signs, traffic markers, and other similar objects within the limits of construction and store in the right-of-way for disposition, as directed by the Engineer.

Add:

Abandon sewers and drainage structures in accordance with the provisions of 202.041.

Delete the fifth paragraph and substitute:

When backfilling is required, backfill the resulting cavities, voids, or trenches within the right-of-way with a CLSM-CDF product meeting the requirements of the HAMCIN specification and identified on the current "List of Acceptable Materials" available on the DOTE website. Areas beyond the right-of-way may be backfilled with Item 203 embankment material or Item 611 Structural Backfill Type 1 or 2, placed and compacted according to 203.

202.04 Pipe Removal.

Add:

Include in the unit price bid for the various sewer items the removal, where required, of all existing house connections which include sanitary, yard, roof, basement or other similar pipe drains within the construction limits, unless otherwise itemized for payment in the Proposal for Item 202 "Pipe Removal - House Connections."

If the Contract requires installation of new conduit in about the same alignment as the existing pipe, then include as incidental the removal of the existing pipe in the price bid for various items.

Add:

202.041 Abandoned Sewers and Drainage Structures.

All existing sewers, manholes, catch basins and inlets to be abandoned or removed as part of the project are noted on the plans.

Abandon noted manholes, catch basins and inlets in accordance with the provisions of Item 202.11.

Remove noted manholes, catch basins and inlets in accordance with the provisions of Item 202.10.

Plug or seal noted sewers where they join manholes, catch basins or inlets. Plug or seal at both ends, where broken into, all existing sewers encountered in construction operations that are inactive or are to be abandoned before proceeding with backfilling and as determined by the Engineer.

Seal pipe one foot (305 mm) or less in diameter with a suitable precast concrete or vitrified clay stopper properly cemented into place. Seal pipe or masonry sewers larger than one foot (305 mm) in diameter at the required locations with masonry bulkheads of brick, stone or concrete having a thickness of one-half of the sewer diameter, with a minimum thickness of one foot (305 mm) and a maximum thickness of two feet (610 mm).

Seal all sewers to be abandoned one foot (305 mm) or less in diameter. Seal and fill all sewers larger than one foot (305 mm) in diameter, as indicated in the Contract plans and/or Contract specifications. Filling may be done hydraulically (using sand or gravel) or by mud jacking (using suitable clay). Fill material must be approved by the Engineer before it is placed. Place enough approved fill material to occupy at least 75 percent of the sewer cross sectional area with solids.

The Contractor has the option to remove existing sewers noted on the Plans to be sealed and filled.

The unit price bid for the various sewer items may include payment for sealing, or sealing and filling abandoned sewers, or for removing abandoned sewers in lieu of sealing and filling same, unless the Proposal for Item 202 "Seal and Abandon Existing Sewers" or Item 202 "Fill, Seal and Abandon Existing Sewers" includes the item.

Add:

202.051 Removing Tree Guards.

Description. Furnish all labor, tools, materials, and equipment necessary for removing tree guards from existing tree grates.

Construction. Remove both halves of the tree guard where it is attached to the tree grate. This usually involves the removal of three bolts located on the underside of the grate. Reset the grate in its original condition. Unless the Engineer otherwise instructs, deliver guards to a specified storage site located within the City limits. Take special care to prevent damage to the tree. Correct or compensate for any tree damage caused by this work as the Supervisor of Urban Forestry determines.

When encountering situations where the tree has physically grown around or through the metal and the removal of such metal may cause harm to the tree, Contact the Supervisor of Urban Forestry before proceeding.

Add:

202.052 Removing Tree Grate From Existing Tree Grate Frame.

Description. Furnish all labor, tools, material, and equipment necessary for removing existing tree grates, including removing bolts from underside of grate. Furnish and install plywood inside grate frame to maintain sidewalk surface.

Materials. Furnish and install 3/4 inch (20 mm) thick plywood, cut to exact dimensions of the grate to be removed. Set the plywood flush with the top of the frame. Treat the plywood with a non-slip surface such as friction tape. Cut the tree opening to allow a uniform six inch (150 mm) space between tree and plywood.

Construction. Carefully lift and support the grate and remove the two bolts that hold the halves together. The grate can then be removed. Install plywood inside grate frame. Dispose of broken grates. Haul intact salvaged grates to a City facility. Take special care to prevent damage to the tree. Correct or compensate for any tree damage caused by this work as the Supervisor of Urban Forestry determines.

Add:

202.053 Street Car Tracks Removed

This item will cover the removal of any abandoned street car base and rails encountered within the confines of the trench during construction of proposed water main(s). The Contractor shall be compensated for this work per linear foot of proposed water main trench in which the rails, base, and/or ties are to be removed.

202.06 Buildings Demolished. Add to third paragraph:

Remove portions of all buildings that are located in the Right-of-Way to a minimum of six feet (1.8 m) below the proposed grade. Remove all cellar doors, coal holes, or basement encroachments in the Right-of-Way and fill resulting void(s) with Controlled Low Strength Material (CLSM-CDF) meeting the requirements of Item 613. Restore disturbed pavement, walk, driveway or sod so it conforms to adjacent surface(s). Replace all disturbed sidewalks and/or driveways from joint to joint.

202.10 Manhole, Catch Basin and Inlet Removed. Add:

Carefully remove and store castings for reuse as the Engineer specifies, or for delivery to a City facility, unless otherwise directed by the Engineer.

The City will not pay for removal under this item if the Contract calls for a new structure where it is necessary to remove the existing structure.

Delete last paragraph and replace with:

Fill resulting void(s) with Controlled Low Strength Material (CLSM-CDF) meeting the requirements of Item 613. Restore disturbed pavement, walk, driveway or sod so it conforms to adjacent surface(s). Replace all disturbed sidewalks and/or driveways from joint to joint.

202.11 Manhole, Catch Basin and Inlet Abandoned. Add:

Carefully remove and store castings for reuse as the Engineer specifies, or for delivery to a City facility, unless otherwise directed by the Engineer.

Delete last paragraph and replace with:

Fill resulting void(s) with Controlled Low Strength Material (CLSM-CDF) meeting the requirements of Item 613. Restore disturbed pavement, walk, driveway or sod so it conforms to adjacent surface(s). Replace all disturbed sidewalks and/or driveways from joint to joint.

202.143 Basis of Payment. Add the following items:

Item	Unit	Description
202	Each	Removing Tree Guards
202	Each	Removing Tree Grate from Existing Tree Grate Frame
202	Lump Sum	Seal and Abandon Existing Sewers
202	Cubic Yard (Cubic Meter)	Fill, Seal, and Abandon Existing Sewers
202	Linear Foot	Removing Street Car Base and Rail (for GCWW Projects)

Item 203 Roadway Excavation and Embankment

203.01 Description. Add to the second paragraph:

Excavation within streets including removing flexible base pavement (i.e. macadam, asphalt, brick, granite, wood block, cobblestone, etc.), and repairing shoulders and other areas as directed by the Engineer, is considered unclassified excavation.

203.04 General.

A. Drainage and Maintenance of the Work. Delete last paragraph and substitute:

Where earthwork operations encounter inactive or abandoned pipe lines, plug or seal and cover them in accordance with 202.041.

203.05 Embankment Construction Methods.

Add at the end of the first paragraph:

Unless otherwise specified, backfill all trenches, holes, pits, and other depressions within the limits of the existing or proposed Right-of-Way with Controlled Low Strength Material (CLSM-CDF) meeting the requirements of Item 613.

Add at end of section:

When embankments are less than three feet (1 m) in depth and are constructed over existing pavement, or if the grade of the existing pavement to be covered is greater than eight percent, break the pavement sufficiently to permit the flow of water through the fractures, and to eliminate a slip plane. The maximum dimension of broken pavement shall be five feet. (1.5 m)

203.06 Spreading and Compacting.

Add to second paragraph:

Encase all embankment with two feet of relatively impervious material free of shale and limestone.

B. Shale.

Add at end of section:

When constructing embankment using a shale and limestone mix, ensure that the limestone pieces do not nest to create voids.

Item 204 Subgrade Compaction and Proofrolling

204.06 Proofrolling.

Remove and replace section A with:

A. Unless otherwise requested or accepted by the Engineer, use a proofroll vehicle comprised of a fully loaded single axle dump truck having a gross vehicle weight of at least 29,000 pounds. Pressure in all tires shall be at least 90 pounds per square inch.

Provide the Engineer with information verifying that the weights and tire pressures are met.

Add:

Item 210 Special Excavation

210.01 Description. Special excavation is excavation that is not included in item 203 Roadway Excavation and Embankment or Item 503 Excavation for Structures, and that is not an integral part of other Contract Items. Special Excavation includes outlet trenches, test holes, removing unsuitable material below the foundation in trenches or other excavations as shown on the plans or as directed by the Engineer. This work includes excavation, trimming and grading, sheeting and bracing, pumping, draining, backfilling and disposal of surplus materials.

210.02 Construction Requirements. Perform Special Excavation as shown on the Plans, or as the Engineer orders. Neatly trim outlet trenches and grade to the cross section indicated or ordered. Where test holes or other special excavations are located between curb lines, fill with CLSM-CDF per Item 613.

210.03 Method of Measurement. The City will measure the cubic yards (m³) of Special Excavation based on the material volume (in its original position) using the average end-area method.

210.04 Basis of Payment. The City will not make separate payment for trimming and grading, sheeting and bracing, pumping, draining, or disposal of surplus materials incidental to this work. The City will pay only for the Special Excavation indicated on the Plans, called for in the Special Provisions, or ordered by the Engineer. The City will pay for accepted quantities at the Contract prices as follows:

Item	Unit	Description
210	Cubic Yards (Cubic Meters)	Special Excavation

Item 211 Special Fill Material

211.01 Description. Furnish and place Special Fill Material upon the express direction of the Engineer when the Work requires this particular type of material and it is not available from excavation on the improvement. Special Fill Material is granular material as defined in 703.11 that will compact solidly under wetting and rolling. Place Special Fill Material in strict accordance with the applicable provisions of 603.10 and 703.11.

211.02 Method of Measurement. The City will measure Special Fill Material by the number of tons (metric tons) incorporated in the complete and accepted work. Turn in to the Engineer each day certified weight bills showing the number of tons of material furnished. The foreman on the job and the Inspector must sign each slip.

Where the Special Fill Material is used to backfill a sewer trench, the City will measure the number of tons (metric ton) used above the initial backfill one foot (300 mm) above the pipe, to the subgrade and for the maximum trench width allowed for sewers in street area, as

shown on Standard Drawing Acc. No. 49032. For conversion of volume to tons (metric tons) for payment under this Item, Bank Run Gravel is considered to weigh 3,400 pounds per cubic yard (1,179 kg/m³).

211.03 Basis of Payment. The City will pay for accepted quantities at the Contract prices as follows:

Item	Unit	Description
211	Tons (Metric Tons)	Special Fill Material

250 PAVEMENT REPAIRS

Item 251 Partial Depth Pavement Repair

251.01 Description.

Add:

Adhere to Engineering Division Standard Drawing Accession No. 21513.

251.02 Removal of Existing Pavement. Delete the last sentence of the first paragraph.

251.03 Placement of Asphalt Concrete. Replace the first sentence in the third paragraph with the following: Thoroughly compact the final lift using a steel wheel roller that conforms to 401.13. Delete the fifth paragraph.

251.05 deleted

Item 252 Full Depth Rigid Pavement Removal and Flexible Replacement

252.01 Description. Add:

Adhere to Engineering Division Standard Drawing Accession No. 21512. The minimum depth of the full depth asphalt concrete repair is 12 inches.

252.02 Removal of Existing Rigid Pavement. Delete and replace with the following:

The Engineer will locate and mark all areas for repair before the start of diamond sawing.

Saw cut the existing rigid pavement full depth at the limits of the area designated by the Engineer using a diamond saw blade. Dispose of the removed pavement according to Item 202.

252.03 Correction of the Subgrade. Add the following: Excavate subgrade or subbase material to achieve the minimum 12 inch repair thickness. Include the cost of subgrade or subbase removal in the price bid for this item.

252.04 Placement of Asphalt Concrete. Replace "pneumatic tire roller" in the first sentence of the third paragraph with "steel wheel roller".

Add to the fourth paragraph:

Achieve an in-place density of the compacted material equal to or greater than 92% as determined by the City's testing agent.

Add to the end of this section:

Complete all areas of full depth pavement removal at the end of each day's operation and open roadway to the normal flow of traffic.

252.05 Method of Measurement. Delete the second paragraph of this section.

252.06 Basis of Payment. Replace the first paragraph with the following: Payment is full compensation for furnishing all materials, removing pavement, including full depth pavement sawing, correcting the subgrade/subbase, placing flexible pavement, and for all labor, equipment, and incidentals necessary to complete this work.

Item 253 Pavement Repair

253.01 Description.

Replace with the following:

This work consists of full depth removal of existing flexible base pavements, such as asphalt concrete, brick, granite, limestone, wood block, cobblestone, macadam, or other stone/cinder/gravel base pavements; shaping and compacting the exposed material; and placing new asphalt concrete pavement or aggregate and asphalt concrete pavement courses.

253.02 Removal of Existing Pavement.

Replace with the following:

The Engineer will locate and mark all areas for repair before the start of diamond sawing. Saw cut the existing pavement full depth at the limits of the area designated by the Engineer using a diamond saw blade. Dispose of the removed pavement according to Item 202.

Excavate subgrade or subbase material to achieve a minimum 12 inch repair thickness. Include the cost of subgrade/subbase removal in the price bid for this item.

253.03 Placement of Asphalt Concrete.

Delete this section and replace with 252.04 with the following revisions:

Replace "pneumatic tire roller" in the first sentence of the second paragraph with "steel wheel roller".

Add to the third paragraph:

Achieve an in-place density of the compacted material equal to or greater than 92% as determined by the City's testing agent.

Add to the end of this section:

Complete all areas of full depth pavement removal at the end of each day's operation and open roadway to the normal flow of traffic.

253.05 Basis of Payment. Replace the first paragraph with the following:

Payment is full compensation for furnishing all materials, removing pavement, including full depth pavement sawing, correcting the subgrade/subbase, placing flexible pavement, and for all labor, equipment, and incidentals necessary to complete this work.

Item 254 Pavement Planing

254.03 Planing.

Add the following:

No featheredge joints permitted. Form butt joints, at least one inch in depth, along the limits of the grinding area. Place temporary asphalt wedges along all butt joints, driveways and curb ramps.

Upon completion of the planing work, place temporary asphalt wedges along all butt joints, driveways, and curb ramps. Immediately tack and place a compacted 441, Type 1 hot-mix asphalt wedge around all exposed utility castings within the planed area. For castings exposed up to two inches, place a wedge with a minimum diameter of six feet around the of eight feet around the casting.casting. For castings exposed greater than two inches, place a wedge with a minimum diameter

Include the cost of asphalt wedging after planning operations in the price bid for this item.

Either remove asphalt wedges prior to placement of the intermediate course, or the asphalt wedges may remain in place for the placement of the intermediate course if the wedges are properly tacked and compacted to the satisfaction of the Engineer.

254.07 Basis of Payment.

| Delete the second sentence of the first paragraph. Add the following:

Payment includes the placement and removal of asphalt wedges per 254.03 of this Supplement, and, if applicable, the removal of any existing asphalt speed humps.

**Item 255 Full Depth Rigid Pavement
Removal and Rigid Replacement**

255.03 Removal of Existing Pavement. Delete the second sentence of the first paragraph. Delete all but the last sentence in the third paragraph and delete the fourth paragraph of this section.

255.07 Wearing Course Replacement.

| Delete the first sentence of first paragraph. Replace:

| "material as shown in plans" in the second sentence with "Item 441 Type 1". In the third sentence, replace "any of the roller types" with "a steel wheel roller".

| Add to the beginning of the third paragraph:

"If the Contract does not include resurfacing,"

255.09 Method of Measurement.

Delete the second paragraph of this section.

255.10 Basis of Payment.

Add:

"sawing pavement full depth;" to the end of the first sentence of first paragraph

| In the fourth paragraph delete "Item 301".

300 BASES

Item 304 Aggregate Base

304.02 Materials.

Add:

The use of crushed recycled concrete is prohibited unless the Special Provisions, Detailed Provisions or the General Notes specifically permit it.

400 FLEXIBLE PAVEMENT

Item 401 Asphalt Concrete Pavements - General

401.03 Materials.

Add:

703.05 Coarse Aggregate must be 100 percent crushed.

401.04 Reclaimed Asphalt Concrete Pavement (RAP) and Reclaimed Asphalt Shingles (RAS).

Add the following to the second paragraph:

Do not use the RAP contained within the bottom one foot of the RAP stockpile in any asphalt concrete mixes.

401.06 Weather Limitations.

Delete the last paragraph and substitute the following:

Do not schedule the placement of any surface course with a polymer modified asphalt binder after November 1st unless approved by the Engineer

401.15 Spreading, Finishing and Night Work. Add to the last paragraph under the "Spreading and Finishing" section:

Do not seal gutters within the limits of curb ramps.

401.22 Basis of Payment.

Add:

Unless otherwise specified, include the cost of Item 407 – Tack Coat in the respective contract prices for the asphalt concrete intermediate and surface course items.

Item 403 Asphalt Concrete Quality Control and Acceptance

403.02 General.

Delete the second paragraph.

403.03 Quality Control Program (QCP).

Delete the last sentence of the first paragraph.

Delete the second paragraph.

Delete the fourth paragraph.

403.04 Plant Calibration. Delete the second paragraph.

Item 421 Microsurfacing

421.08 Surface Preparation. Delete third paragraph. Delete the last paragraph and substitute: Remove all pavement markings using an abrasion method conforming to 641.10. Document the locations of all utility castings and inlet grates within the project limits. Furnish and place suitable protective covers over all of the utility castings and inlet grates before starting work. Upon completion of the microsurfacing work, remove all of the protective covers to expose the castings and inlet grates.

421.09 Test Strip. Delete this section.

Add:

421.101 Construction Operation. Sweep the pavement using a power broom or pickup sweeper as needed to remove all loose aggregate within 48 hours upon completion of the microsurfacing work. Sweep pavement again before the application of the final pavement markings. Perform a final sweeping approximately 30 days after the completion of the work.

Before opening to traffic, post the roadway with "Loose Stone" signs and a "25 mph" speed plaque mounted below the sign. Ensure that the signs conform to Item 614. Place these signs at the limits of work including at all intersecting streets. Remove the signs as directed by the Engineer.

421.14 Basis of Payment.

Delete the first paragraph and substitute:

The costs of tack coat, covering and uncovering the utility castings and inlet grates, Item 423 Crack Sealing and sweeping of loose aggregate are incidental to Microsurfacing.

Item 442 Superpave Asphalt Concrete

442.08 Basis of Payment.

Add (for Utility Restoration Work):

Item	Unit	Description
442	Square Yard (Square Yard) Course, 12.5 mm, Type A (448)	Asphalt Concrete Surface
441	Square Yard (Square Meter)	Asphalt Concrete Surface Course, Type 1 PG 64-22

450 RIGID PAVEMENT

Item 451 Reinforced Portland Cement Concrete Pavement

451.07 Placing Concrete.

Delete last paragraph and add the following paragraphs:

The City prepares four test cylinders from each 100 cubic yards (90m³) of concrete, or fraction thereof, each day. Test cylinders are made and tested in accordance with ASTM C 31 AND C 39. Testing includes breaking one cylinder after 7 days and two cylinders after 28 days (one cylinder is a "hold" cylinder).

Use concrete, which develops an average seven-day compressive strength of 2,900 psi (20,000 kPa) and a minimum strength of 2,400 psi (16,550 kPa) and develops an average 28 day compressive strength of 4,000 psi (27,575 kPa) and a minimum strength of 3,400 psi (23,450 kPa). Increase the cement content of the mix without additional cost to the City when cylinders fall below the average compressive strengths of 2,900 psi (20,000 kPa) (seven-day) or 4,000 psi (27, 575 kPa) (28-day). Pavement will be rejected when cylinders fall below the minimum compressive strengths of 2,400 psi (16,550 kPa) (seven-day) or 3,400 psi (23,450 kPa) (28-day).

Plan work so that the placing of concrete proceeds from the lower to the higher points along the profile of the street. Concrete placement may not proceed from higher to lower points when the grade is more than three percent without the approval of the Engineer.

451.09 Joints.

D. Contraction Joint.

Add after the final paragraph:

Construct contraction joints approximately 15 feet (4.6 m) apart unless otherwise directed by the Engineer, or unless otherwise indicated in the bidding documents.

Add at the end of this section:

Plan and execute paving and sawing operations so that any paving and/or sawing work is not in violation of the City's Noise Ordinance unless otherwise directed or authorized in writing by the Engineer.

451.10 Finishing.

Delete the last paragraph of this section.

451.12 Removing Forms.

Add:

Cure concrete for at least 12 hours before removing forms. Leave the forms in place for at least 48 hours when the temperature is below 50° F. (10° C).

Item 452 Non-Reinforced Portland Cement Concrete Pavement

452.02 Construction.

Delete the second paragraph and substitute:

Do not comply with the requirements of 451.08 and the last paragraph of 451.10 regarding impressing station numbers in the new pavement.

500 STRUCTURES

Item 501 Structures – General

501.02 Verification of Dimensions.

Add:

Perform all verifications prior to submitting shop or working drawings to the City and include a statement on the drawings that verification has been performed together with information identifying person or persons performing the verification.

501.04 Shop Drawings.

A. Contractor Acceptance of Shop Drawings for Items 513 and 515.

Delete the first paragraph and substitute:

After preparing the shop drawings for Items 513 and 515, submit five full-sized paper copies of the shop drawings to the City at least 30 days before the start of fabrication. The City will retain three copies of the shop drawings. The City and/or its designated agent will review the shop drawings in accordance with 105.02. Do not begin fabrication until the shop drawings have been accepted by the City. Leave a 3-1/2 inch by 3-1/2 inch blank space next to the title block for the review stamp.

Delete the last paragraph and substitute:

Schedule the pre-fabrication meeting after the shop drawings have been accepted by the City. Fabrication may begin after the pre-fabrication meeting is complete.

B. Fabricator Coordination of Shop Drawings for Items 516, 517 and 518.

Delete the second paragraph and substitute:

Submit five full-sized paper copies of the shop drawings to the City at least 30 days before the start of fabrication. The City will retain three copies of the shop drawings. The City and/or its designated agent will review the shop drawings in accordance with 105.02. Do not begin fabrication until the shop drawings have been accepted by the City.

C. Shop Drawing General Requirements.

Delete the second and third paragraphs and substitute:

Prepare the drawings using computer aided drafting software. Print drawings to scale on 22 x 34 inch (559 x 864 mm) sheets. Leave a 3-1/2 inch by 3-1/2 inch blank space next to the title block for the review stamp.

After all fabrication is completed for Items 513, 515, 516, 517 and 518, furnish one set of all shop drawings as corrected on mylar sheets and one copy of all drawings in PDF format on CD to the Engineer. Name PDF files using the drawing title unless the Engineer directs otherwise. Mark drawings and scanned files to indicate they are part of the Record Set.

501.05 Submittal of Working Drawings and Calculations.

A. Projects with Railroad Involvement.

Delete the sentence:

“Department acceptance is not required.” in the second paragraph and the sentence “Department acceptance of revised working drawings is not required.” in the third paragraph.

B. Projects without Railroad Involvement. Delete the sentence “Department acceptance is not required.” in the third paragraph and the sentence “Department acceptance of revised working drawings is not required.” in the fourth paragraph.

Replace:

6. When the total load applied to a structure during construction (new or structure being rehabilitated) exceeds 75 percent of the Legal Limit, (the Legal Limit is 80,000 lbs. or percentage thereof if the structure is posted) analyze the effects of the load on the structure based on the Operating Level as calculated using the Load Factor Rating Method as given in the *AASHTO Manual for Bridge Evaluation*.

Item 509 Reinforcing Steel

509.11 Basis of Payment.

Delete the second paragraph and substitute:

The City will pay for accepted quantities at the Contract price as follows, unless the Special Provisions, the Detailed Provisions and/or the General Notes stipulate that payment for reinforcing steel will be included in the Contract prices for Item 510, 511, 519, 520, or any other item specified:

Item 511 Concrete for Structures

511.04 Quality Control Requirements and Mass Concrete.

Add to the third paragraph:

A set of test cylinders consists of at least five cylinders.

511.14 Curing and Loading.

Delete Table 511.14-2 and substitute:

Location	Curing Method*
Superstructure Concrete	Method B followed by Method A
Concrete to which sealer is to be applied	Method A
Construction joints	Method A
Top surface of deck superstructure concrete	Method B followed by Method A
Concrete with waterproofing	Method A or Method B
All other concrete	Method A or Method B

*

Method A is water curing. Method B is membrane curing. If using Method B on areas to be waterproofed, remove the curing membrane after the cure period has elapsed.

Met

Item 512 Treating Concrete

512.03 Sealing of Concrete Surfaces.

Delete paragraph G.1.e. and substitute:

Unless otherwise noted in the Plans, tint so the final color is as selected by the Engineer from all available colors and/or hues. Limit pigment content so as not to reduce sealing effectiveness of the second coat.

Item 513 Structural Steel Members

513.07 Levels 1 through 6, Prefabrication Meeting.

Replace the last sentence with:

After the shop drawings have been returned marked "Accepted" or "Accepted as Noted", fabrication may begin.

Item 519 Patching Concrete Structures

519.06 Placing, Finishing, and Curing of Concrete.

Add:

Notify the Engineer at least 24 hours in advance of sounding any patched area.

Item 520 Pneumatically Placed Mortar

520.11 Inspection and Testing.

Add:

Notify the Engineer at least 24 hours in advance of sounding any patched area.

Item 524 Drilled Shafts

524.10 Concrete for Drilled Shafts.

At the end of the first paragraph, add:

Class QC 1 concrete meeting the requirements of Item 511 may be used as modified and supplemented above, except the accepted JMF's maximum water cementitious ratio shall not be exceeded.

524.14 Construction Tolerances.

Delete first paragraph and substitute:

Locate the center of the shaft within one inch (25 mm) of the designated location. Drill shaft so that it is plumb within 1/8 inch per foot (10 mm per meter) of length. Correct any shaft varying by more than the above tolerances to the satisfaction of the Engineer.

If the depth to bedrock exceeds the limits shown on the plans by more than one foot (305 mm), cease drilling operations and contact the Design Engineer. The Design Engineer will assess the conditions and, if required, inform the Contractor of the additional shaft depth and the additional steel reinforcement requirements.

524.17 Basis of Payment.

Substitute:

“required excavation, including any excavation and benching for the drilling operations;” for “required excavation”.

At the end of the first paragraph, add:

Include all costs of mobilizing and removing equipment in the unit Contract prices. Repair damage to the existing roadway from drilling, excavation or benching at no cost to the City.

600 INCIDENTALS

Item 601 Slope and Channel Protection

601.08 Dumped Rock Fill.

Add the following sentence to this section:

Complete the dumped rock fill to the thickness shown on the Plans.

601.09 Rock Channel Protection.

Add the following sentence to this section:

Complete the rock channel protection to the thickness shown on the Plans.

Item 602 Masonry

602.01 Description.

Add after the word "headwalls": "key blocks,"

602.02 Materials.

Replace the requirements for "Water for grout and mortar" with:

Water for grout, mortar and wetting blocks/bricks.....Cincinnati hydrant water or equal

602.03 Construction Requirements.

Add to the end of Section A:

After the excavation has been made and the sides securely supported where necessary, hand trim and shape the bottom of the excavation to conform to the outside of proposed structure. The foundation must be solid and entirely free from mud and water before commencing with block or brick laying.

Delete the fourth paragraph and substitute:

Excavate deeper if the material found at grade is not suitable for foundation. Excavate to provide a suitable foundation, and fill with suitable material. Payment for additional excavation and backfill is to be as specified in 603.05 of this Supplement.

Delete Section C and substitute:

Construct concrete headwalls, concrete cradles and other concrete masonry using the materials and by the methods as described under 499 and 511, and of the Class shown on the Standard Drawings, or of Class QC1 if no class is specified. Reinforcing steel shall be placed as prescribed under 509.

E. 15. Shop Drawing General Requirements:

Delete Section "b" and substitute:

Submit shop drawings in accordance with the requirements of 501.04. Prepare shop drawings as if the items were of 513, 515, 516, 517, or 518 origins.

Delete Section "F" and substitute:

Construct block or brick walls to the thickness called for on the plans. Thoroughly wet blocks or bricks before placing in mortar. All block or brick used in the Work must be clean and

entirely free from dirt, paint, grease and all other foreign substances. Lay up with full mortar joints. Use mortar consisting of one part Portland cement to two parts of sand by volume. Mix the materials dry until the color is uniform, add water and continue mixing until a stiff homogeneous mass is produced. Thoroughly mix all mortar in suitable water-tight boxes or in approved mechanical mixers. Mix mortar in small quantities so that each batch may be used before it has taken its initial set. Absolutely no lime may be used in the mortar. Retempered mortar is that which has been remixed with or without the addition of water after the initial set has taken place. Do not retemper mortar under any circumstances.

Spread a layer of mortar 1/2 inch (12 mm) thick upon the prepared foundation, in which clean wet block or brick shall be set. Lay each successive course of block or brick in a full bed of mortar. Lay all block or brick truly horizontal except in such structures that are built to a fixed grade.

In general, lay block or brick with joints pushed closely together, and filled entirely with mortar. Lay all block or brick with broken joints both on the sides and with the course below, and with the masonry thoroughly bonded together. Only whole block or brick may be used in the masonry, with bats being used only to fill interstices and to effect closures. Exposed surfaces must be smooth and even with joints neatly pointed up and thoroughly cleaned of all surplus mortar except where they are to be plastered. First, clean and wet surfaces that are to be plastered, then plaster before the masonry has set, and trowel to a dense, even finish.

Item 603 Pipe Culverts, Sewers, and Drains

- 603.01 Description**
- 603.011 General**
- 603.013 Building Sewers**
- 603.014 T and Y Branches**
- 603.015 Bends**
- 603.016 Plastic Pipe**
- 603.017 Backfilling Plastic Pipe**
- 603.018 Allowable Bedding and Initial Backfill Types for Plastic Pipe**
- 603.019 Deflection Testing for Plastic and Flexible Pipe**
- 603.02 Materials**
- 603.03 Definitions**
- 603.04 Material Provisions**
- 603.05 Excavation**
- 603.06 Bedding**
- 603.07 Laying Conduit**
- 603.08 Joining Conduit**
- 603.09 Exterior Coatings and Membrane Waterproofing**
- 603.10 Backfilling**
- 603.11 Placement and Compaction Requirements**
- 603.12 Clearing Site and Restoring Damaged Surfaces**
- 603.13 Field Paving of New or Existing Pipe**
- 603.14 Method of Measurement**
- 603.15 Basis of Payment**

603.01 Description. Perform work in accordance with City of Cincinnati, MSD Rules and Regulations. Make taps into existing pipes with a plumber licensed by MSD.

This work consists of the construction or reconstruction of pipe culverts, sewers, and drains hereinafter referred to as Type A, Type B, Type C, Type D, Type E, Type F, Type G, Type H and Type I Conduits. Work in accordance with these specifications and in conformity with the lines and grades shown on the Plans or established by the Engineer. This work includes: Excavating for pipes and foundations for same, including clearing and grubbing and the removal of all materials necessary for placing the pipe except removals listed separately; furnishing and placing granular or concrete bedding and CDF or granular backfill as required; constructing and subsequently removing all necessary cofferdams, cribs and sheeting; pumping and dewatering; sealing or banding all pipe joints where required; furnishing and installing all necessary pipe bends and branches of a type at least equal to the conduit of which they become a part; joining to existing and proposed appurtenances as required; and restoration of disturbed facilities and surfaces.

Use removed or excavated materials in the Work when the material conforms to the specifications; if not, then recycle or dispose of the material according to 105.16 and 105.17.

603.011 General. Conduct operations so as to maintain any sewage flow uninterrupted throughout the construction period. Subsurface structures encountered in the prosecution of the work shall be protected and maintained in complete operation unless permission for their removal or relocation is given.

Handle sewerage, where existing sewers are to be removed, in the trench or through closed conduits, and not pumped, bailed or flumed over the street surface or in the gutters. Include any additional costs involved in maintaining this flow by pumping or by any other approved method, in the Contract unit price bid for the respective Items of 603 Conduit.

Locate the existing pipe at the places where the Plans provide for proposed drainage pipe to be connected to existing pipes both as to line and grade, before starting to lay the proposed pipe.
the cost of this operation, and the cost of connecting proposed sewers to existing manholes or sewers in the Contract unit bid for the pertinent 603 Conduit Item.

Seal the pipe joint where connections are made between rigid and flexible pipe sections or between pipe sections of different kind or type of end fabrication whether; required by the Plans, arising from permissible use of optional materials, or encountered in connection to existing facilities, as required by the specifications by means of a concrete collar, Type A or Type B as shown on Standard Drawing Acc. No. 49031. Use adaptive couplings if the Engineer approves or requires them.

When bell and spigot pipe is used, any necessary pipe cut-offs will be made at the spigot end of the length of pipe adjacent to the end length. When tongue and groove pipe is used, the length of pipe adjacent to the end length shall be cut and butt joint formed with a concrete collar, Type A or Type B as shown on Standard Drawing Acc. No. 49031.

Include payment for concrete collars, Type A and Type B under 602 Concrete Masonry, unless otherwise provided in the Contract.

Plug or seal new pipes where required, in accordance with the requirements outlined in 202.041 "Abandoned Sewers and Drainage Structures." Include payment for this work in the Contract unit price bid for the pertinent 603 Conduit Item.

603.013 Building Sewers. At the property owner's sole cost, furnish all material and labor required to install the building sewers from either an existing sewer that is to remain or to a proposed carrier sewer, to a point beyond the limits of roadway construction.

Cooperate with the property owner to give ample opportunity to extend sewer connection from the existing sewer to a point beyond roadway construction limits. Include cost in the Contract unit price bid for the various 603 Conduit Items.

Replace all existing building sewers including; sanitary, yard, roof, basement or other similar pipe drains now in use, that are disturbed because of the improvement. Provide a satisfactory building sewer if the existing sewer is to be abandoned. Include payment for this work in the Contract unit price bid for the pertinent 603 Conduit Item.

Reconnect any unrecorded active connection to a sewer encountered in construction, to the existing or proposed sewers as directed by the Engineer. Include payment for this work in the Contract unit price bid for the pertinent 603 Conduit Item.

Construct building sewers, either by agreement with the property owner or under the Contract, in accordance with all applicable provisions of 603 of this Supplement.

Under usual conditions, lay the drain on a grade of not less than two percent, and where it crosses the property line, a minimum depth of seven feet (2.1 m) measured down from the curb grade to the flow line. Building sewers are deeper than the usual case cited above when it is intended that the building sewers serve low lying lots or deep cellars. The Contractor's attention is called to the requirements of the Cincinnati Building Code concerning building sewers.

In case the depth of the main sewer or the grade of the cellar is such that the depth of the house drain must be varied from the above figure of seven feet (2.1 m), special directions will be given regarding construction of the house drain. Construct building sewers as illustrated on Standard Drawing Acc. No. 49033. Excavate for the stack or riser beyond the sewer trench into firm ground in a trench or slot, which shall be a minimum of 20 inches square (500 mm x 500 mm).

Encase the stack or riser a minimum of six inches (150 mm) of Class QC1 concrete or four inches (100 mm) of brick masonry.

Defer backfilling building sewers until the Inspector obtains the elevation at the end of the building sewer or the vertical distance from the invert of the building sewer to the invert of the main sewer.

Seal the open ends of all unconnected building sewers with stoneware stoppers properly cemented into place. Mark the location of the ends of building sewers with wood strips not less than two inches by six inches (50 mm x 150 mm) in cross section and extending vertically from the end of the drain to a point 24 inches (610 mm) above the sidewalk grade. If at any time during construction the wood strips are broken or not apparent, uncover and replace them. When the sidewalk spaces and slopes are fine graded, cut strips to two inches (50 mm) below the finished grade. When the sewer branches are installed as part of a private improvement, as in the development of a subdivision, install the wood strips as above and protect in place until final inspection has been made of the improvement, at which time they may be cut down to ground level.

603.014 T and Y Branches. Construct straight pipe with T-branches where directed by the Engineer in strict accordance with the provisions of Section 603 of this Supplement. In laying the pipe, incline T-branches upward at an angle of about 45 degrees. Seal unconnected T-branches with stoneware stoppers properly cemented into place or seal using a stub and cap.

Keep an accurate record of the locations of all T-branches and furnish to the Engineer upon request.

The use of a Y-branch is encouraged when it is necessary that a branch leave the main sewer at an angle of more than 20 degrees from the perpendicular. When there is a head end manhole at the terminus of a street requiring several branches to enter the sewer at various angles, the use of Y-branches will be required. Do not connect building sewers to a manhole unless the Engineer has granted specific permission. Enter the sewer through the bench the same as other sewers, when such permission is granted.

Use wye fittings or approved saddles for all six inch (150 mm) connections to plastic pipe.

603.015 Bends. Install vitrified clay, plastic, or concrete bends, curves and elbows where required or as directed in laying or reconnecting building sewers and in the construction of stacks. Furnish and install in strict conformance with the applicable provisions of 603 of this Supplement. Include payment for this work in the Contract unit price bid for the various 603 conduit items.

603.016 Plastic Pipe. Meet the applicable ASTM specification requirements in all Pipe Manufacturer certification. Provide the Inspector/Engineer with certification forms, together with a report of the test results with pipe deliveries. Include project name, location, Contractor, and the test lot number on certification forms. The Engineer approval is required for the lot size.

Suitably mark all pipe and fittings to provide manufacturer's name, lot or production number, ASTM designation, ABS or PVC, and nominal diameter. Label all pipe with a "home" mark. Fittings need not contain lot or production number.

Flexible manhole joints are used with this pipe type.

603.017 Backfilling Plastic Pipe. Install pipe in full compliance with the Recommended Practice for "Underground Installation of Flexible Thermoplastic Sewer Pipe," ASTM Designation D-2321 - latest edition.

In addition to the construction and testing procedures outlined in other sections of the specifications, install the pipe with deflection of the pipe less than five percent and the materials surrounding the pipe compacted to not less than 90 percent Proctor. The area requiring compaction includes the bed and side fill material and also the material placed above the pipe for a distance of 12 inches (305 mm) over the top of the pipe. The Engineer may require random compaction tests to be conducted by an independent laboratory.

If any of these tests indicate that the material has not been compacted to the required density, recompact material at no additional cost to the Owner. The Engineer then has the right to require additional compaction to the proper density without any additional cost to the owner.

603.018 Allowable Bedding and Initial Backfill Types for Plastic Pipe.

Class I - Angular 1/4 inch to 1-1/2 inch (6 to 40 mm) graded stone, including a number of fill materials such as coral, slag, cinders, crushed stone, crushed shells, and shells. Where any ungraded (one size aggregate) crushed stone, coral, or slag is used, limit size to 3/4 inch (20 mm) maximum. Use this material when the depth of cover on the conduit is between 14 feet and 35 feet (4 and 11 meters).

Class II - Coarse sands and gravels with maximum particle size of 1-1/2 inch (40 mm) including various graded sands and gravels containing small percentages of fines, generally granular and non-cohesive, either wet or dry. Soil Type GW, GP, SW and SP are included in this class as spelled out in ASTM D-2487. Use this material for conduits when the depth of cover is 14 feet (4 meters) or less.

603.019 Deflection Testing for Plastic and Flexible Pipe. Provide all equipment (including mandrel) and materials and do all work necessary to conduct tests to determine any structural problems with the installed gravity sewer line.

Perform a pipe deflection test on all gravity sewer pipe installed. The maximum limit of ring deflection is five percent of the base inside diameter. In any area where deflections exceed five percent, re-excavate the trench, the pipe zone backfill and embedment and replace in accordance with the original specifications. If in the opinion of the Engineer, the pipe has been damaged, remove and replace with new pipe installed in full accordance with the specifications.

Measure all pipelines for vertical ring deflection no earlier than 30 days after completion of the backfill.

Provide deflection probes in accordance with the respective ASTM Specification dimensions.

Use a nine-arm mandrel having a diameter equal to 95 percent of the base diameter of the pipe as established in ASTM-D-3034. Perform the test without mechanical pulling devices.

603.02 Materials. Furnish materials conforming to:

- Soil and granular embankment 203.02.R
- Structural backfill, Types 1 and 2 703.11

The Engineer will allow Type 3 structural backfill, conforming to 703.11, to be used as bedding below the pipe only when pumping operations do not control severe ground water problems. Place at least 12 inches (300 mm) of Type 1 structural backfill on top of the Type 3 structural backfill to prevent piping.

- Embankment 203.02.R
- Concrete for collars and encasement,

- Class QC1..... 499 and 511
- Concrete for field paving using

- aggregate No. 7, 8, or 78, Class QC1.....499 and 511
- Reinforcing steel (collars and encasement) 509.02
- Mortar 602
- Non-shrink mortar 705.22
- Bituminous pipe joint filler 706.10
- Resilient and flexible gasket joints for:

- Concrete sewer and culvert 706.11

- Vitrified clay, B & S 706.12
- Preformed butyl rubber joint filler 706.14
- 4 X 4 - W1.4 X W1.4 galvanized

- welded wire fabric for field paving..... 709.08
- Type 2 membrane waterproofing 711.25
- Type 3 membrane waterproofing 711.29
- Fabric wrap, Type 712.09
- Joint wrap ASTM C 877
- Buried Liner Waterproofing Membrane 711.22

The Proposal and Plans show the pipe size and kind specified to meet the requirements of the pertinent sections of 706 and 707. Use any of the kinds listed herein under the specified conduit type when the kind of pipe is not specifically itemized. Higher strength 706.01 pipe may be furnished where lower strength 706.01 pipe is specified, higher strength 706.02 pipe may be furnished where lower strength 706.01 or 706.02 pipe is specified, 706.03 pipe may be furnished where 706.02 pipe is specified, higher strength 706.04 may be furnished where lower strength 706.04 is specified, and higher strength 706.08 pipe may be furnished where lower strength 706.08 pipe is specified. A thicker steel of the same corrugation profile may be furnished for 707.01, 707.02, 707.03, 707.04, 707.05, , 707.07, 707.13, or 707.14 conduits where a lesser thickness is permitted or specified.

Specific materials shall be as follows:

Concrete for bedding, collars and encasement (Class QC1).....	499 & 511
Reinforcing steel	509.02
Sand for mortar	703.03
Bituminous pipe joint filler.....	706.10
Granular material for bedding and backfilling shall be durable gravel, sand, slag or crushed stone meeting grading requirements of.....	703.17
or granulated slag	703.08
or bank run gravel.....	703.20
Resilient and Flexible gasket joints (concrete, sewer and culvert).....	706.11
Vitrified clay, B and S.....	706.12

The kinds of pipe permitted for each of the designated types of conduit shall be as follows:

Any storm and/or sanitary sewers that will be turned over to SMU or MSD for ownership must be an approved pipe material. Contact MSD/SMU for currently approved pipe materials.

Type A Conduits – Culverts:

Non-reinforced concrete pipe (Class 3).....	706.01
Reinforced concrete pipe (Class II minimum).....	706.02
Reinforced concrete pipe with S stirrups.....	706.15
Reinforced concrete elliptical pipe (Class II minimum).....	706.04
Reinforced concrete pipe, vitrified clay lined.	706.05
Vitrified clay pipe (extra strength only).....	706.08
Structural plate corrugated steel structures	707.03

Type B Conduits – Storm sewers or sanitary under pavement:

Reinforced concrete pipe (Class II minimum).....	706.02
Reinforced concrete pipe with S stirrups.....	706.15
Reinforced concrete elliptical pipe (Class II minimum).....	706.04
Vitrified clay pipe (extra strength only).....	706.08
Plastic Pipe	Various, Per Contract Documents*

*Use this material for sanitary and combined sewer only when depth of cover is less than 35 feet (10 meters).

Type C Conduits – Storm sewers or sanitary not under pavement:

Reinforced concrete pipe (Class II minimum).....	706.02
Reinforced concrete pipe with S stirrups.....	706.15
Reinforced concrete elliptical pipe (Class II minimum).....	706.04
Vitrified clay pipe (extra strength only).....	706.08
Plastic Pipe	Various, Per Contract Documents*

*Use this material for sanitary and combined sewer only when depth of cover is less than 35 feet (10 meters).

Type D Conduits – Drive pipes and bikeways:

Non-reinforced concrete pipe (Class 3).....	706.01
Reinforced concrete pipe (Class II minimum).....	706.02
Reinforced concrete pipe with S stirrups.....	706.15
Reinforced concrete elliptical pipe (Class II minimum).....	706.04
Vitrified clay pipe (extra strength only).....	706.08
Galvanized corrugated steel conduits, Type I and II	707.01
Galvanized corrugated (3 x 1) steel conduits.....	707.02
Structural plate corrugated steel structures	707.03

Type E Conduits – Miscellaneous small drain connections and headers:

Non-reinforced concrete pipe (Class 3).....	706.01
Reinforced concrete pipe (Class II minimum).....	706.02
Reinforced concrete elliptical pipe (Class II minimum).....	706.04
Concrete drain tile (12" [0.3 m] and under), extra quality	706.07
Vitrified clay pipe (extra strength).....	706.08
Clay drain tile (12" [0.3 m] and under), extra quality.....	706.09
Galvanized corrugated steel conduits, Type I and II	707.01
Galvanized corrugated (3 x 1) steel conduits.....	707.02
Corrugated aluminum pipe underdrains, without perforations	707.21 or 707.22

Type F Conduits – Conduits on steep slopes; underdrain outlets:

Galvanized corrugated (2-2/3 x 1/2) steel conduits, Type I and II	707.01
Galvanized corrugated (3 x 1) steel conduits.....	707.02
Corrugated aluminum alloy pipe underdrains, without perforations	707.21 or 707.22

Type G Conduits

Ductile Iron Pipe 748.01

Type H Conduits (Inlet Connections)

Non-reinforced concrete pipe (Class 3)..... 706.01

Vitrified clay pipe (extra strength only)..... 706.08

Reinforced concrete pipe (Class II minimum)..... 706.02

Type I Conduits (House Drains)

Plastic Pipe 707.45*

*Use this material for sanitary and combined sewer only when depth of cover is less than 35 feet (10 meters).

603.03 Definitions. For the purposes of this specification, the following definitions are used:

A. Long span structure includes all of the following material kinds: 706.05, 706.051, 706.052, 707.15, and 707.25.

B. Plastic pipe includes all of the following materials kinds: 707.31, 707.32, 707.33, 707.41, 707.42, 707.43, 707.44, 707.45, 707.46, 707.47, 707.51, 707.52, and 748.02.

C. Corrugated metal pipe includes all of the following material kinds: 707.01, 707.02, 707.03, 707.04, 707.05, 707.07, 707.11, 707.12, 707.13, 707.14, 707.21, 707.22, 707.23, and 707.24.

D. Iron pipe includes the following material kind: 748.01.

E. Rigid Pipe includes all of the following material kinds: 706.01, 706.02, 706.03, 706.04, 706.08, 706.09, and 748.06.

F. Conduit includes long span structures, pipe, culverts, sewers, drains, or any other item specified herein.

G. Backfill is soil, granular embankment, or structural backfill placed above the bedding to the elevation as describe.

H. A cut situation is an existing field situation when the top of the conduit is below the existing ground where an embankment may be constructed.

I. A fill situation is an existing field situation when the top of the conduit is above the existing ground where an embankment is to be constructed.

J. A fill situation, meets the requirements of a cut if the fill is constructed to at least 2 feet (600 mm) above the top of the conduit before placing the conduit.

K. The conduit rise is the vertical distance from outside wall to outside wall or outside corrugation measured at the middle of the conduit.

L. The conduit span is the horizontal distance from outside wall to outside wall or outside corrugation measured at the widest point of the conduit.

M. The conduit spring line is equal to the rise divided by two.

N. Trench width is the horizontal distance between the vertical walls of the Trench measured in feet.

603.04 Material Provisions.

The Engineer will allow any of the following alternate material provisions:

A. The Contractor may use Type 1 or 2 structural backfill if granular or soil embankment is required or allowed.

B. Supply pipe of the required size or one size larger.

C. If 707.05 or 707.07 conduit is specifically itemized or specified in the Proposal, the Contractor may provide conduit conforming to 707.04 and having a bituminous paved invert. Provide the same corrugation profile and sheet thickness listed in the Proposal.

D. The Contractor may furnish higher strength concrete or plastic pipe of the same type where lower strength pipe is specified.

E. The Contractor may furnish a thicker metal pipe of the same corrugation profile and type where a lesser thickness is permitted or specified.

F. If 706.02 reinforced concrete pipe is specifically shown on the plans as "special design", the manufacturer shall submit shop drawings and design calculations by a Registered Engineer for review and written approval before manufacture. Submit a minimum of seven copies of the shop drawings and allow a minimum of 4 weeks for approval. Include the following in the shop drawings:

1. All structural design and loading information.
2. All material specifications.
3. All dimensions.

Design reinforced concrete pipe based on *AASHTO LRFD Bridge Design Specifications*, Section 12.

G. If a 706.05 structure is specifically itemized or specified in the Contract, the Contractor may submit, to the Department for approval, a request to supply a 706.051 structure placed on

precast slab bottom, or a 706.052 structure placed on precast slab bottom, that is hydraulically equivalent and meets all cover requirements. These structures and slab bottoms shall conform to the preapproved design by a Registered Engineer from approved manufacturers on file with the Department. Manufacturers not approved may submit structural design criteria, analysis method, and structure details for approval. The manufacturer shall submit shop drawings and hydraulic calculations by a Registered Engineer for review and approval before manufacture. The bottom slab may be cast-in-place with approval from the Department however there will be no increase in time permitted.

H. If 706.051 or 706.052 is specifically itemized or specified in the Contract, on footers, the Contractor may substitute each one for the other upon structure approval for hydraulics and cover. The manufacturer shall submit shop drawings and hydraulic calculations by a Registered Engineer for review and approval before manufacture. If 706.051 or 706.052 is specifically itemized or specified in the Contract, on pedestal walls, the Contractor may substitute each one for the other upon structure approval for hydraulics, cover and pedestal wall design. 706.051 or 706.052 require different pedestal wall designs.

I. All 706.051 or 706.052 shop drawings require a Registered Engineer signature for design and check. The manufacturer shall submit shop drawings and hydraulic calculations to the Department for review and approval before manufacture.

J. For metal pipe 54 inch (1350 mm) diameter or larger and pipe-arch, ensure the manufacturer provides match marked ends and a layout drawing.

603.05 Excavation.

Excavation includes the loosening, handling, re-handling, removal, filling and disposal of any and all materials, wet or dry, including gumbo, quicksand, hardpan, shale, rock, roadway pavement and all unforeseen obstacles.

Construction In or Under Embankments. Where pipe sewers are to be placed within or beneath an embankment, and the upper extremity of the pipe will be less than three feet (914 mm) below the surface of the original ground, construct the embankment to an elevation of at least three feet (914 mm) above the upper extremity of the pipe, or to the surface of the completed embankment if less than three feet (914 mm) above the upper extremity of the pipe, before trenching for the pipe. Then excavate the trench to the minimum width necessary for placing the pipe and backfilling properly. Lay the pipe and backfill the trench before additional embankment is placed thereon.

Open Cuts. Open cut or trench all excavations except where trench-less construction is required on the Plans. Unless so required, no trench-less construction will be permitted except by written permission or order obtained from the Engineer before beginning the work. The City reserves the right to rescind such order at any time during the progress of the Work.

Widths and Depths. Excavate sufficient width and depth to permit and facilitate construction to the lines, grades and dimensions shown on the Plans, and for sheeting, bracing, pumping, draining and other construction operations. In construction of pipe sewers, excavate

trenches to the widths and depths governed by control dimensions for typical trenches shown on Standard Drawing Acc. No. 49032.

Extra Excavation and Refill. If any excavation is carried below the required depth, remove the loosened material and fill the extra space with concrete of the same class as that to be used in the bottom of the structure or as specified for bedding on Standard Drawing Acc. No. 49032 without additional cost to the City.

The foundation for the conduit bed shall be firm for its full length. Where unstable material is encountered below the foundation, remove to the depth directed by the Engineer under the conduit and for a width on each side equal to the diameter or span of the conduit and replace with granular material. Remove rock or boulders encountered at the conduit bed at least six inches (150 mm) below the bottom of the conduit and replace with granular material.

The proposed elevations of manholes and pipes and the estimated lengths of pipe may be adjusted by the Engineer during construction.

Change the flow line, not to exceed one foot (305 mm), or remove unsuitable material at the direction of the Engineer in an amount not to exceed one foot (305 mm), at the same Contract bid price.

When the flow line is lowered more than one foot (305 mm) or if it becomes necessary to remove more than one foot (305 mm) of unsuitable material below the bottom of the trench, compensation will be provided therefore under 210 and 211.

Length of Openings. Conform the length of all openings to the limits shown on the Plans. The lengths of all openings are subject to the review and approval of the Engineer.

Sheeting and Bracing. Furnish, place and maintain such sheeting and bracing as may be required by the **Site Safety Plan, OSHA requirements**, or the opinion of the Engineer, to securely support the sides and ends of the excavations, and to prevent injury to the structure being built or to persons or property. If at any time the City so orders, install such additional sheeting and bracing as the Engineer may consider necessary. Compliance with such orders or failure on the part of the City to issue such orders does not release the Contractor from liability for damages resulting from weak or insufficient sheeting, nor from responsibility for protecting The Work and adjacent property from damage. Immediately and compactly fill the voids appearing outside the sheeting with suitable material in a satisfactory manner. Sheeting and bracing may be left in place unless otherwise ordered by the Engineer. Never remove sheeting and bracing until sufficient backfill has been placed to provide ample support to the sides of the excavation as determined by the Engineer. When sheeting is left in place, cut it off at least six feet (1.83 m) below the proposed finished surface if within the roadway or at least three feet (914 mm) below the proposed finish surface if beneath the sidewalk space. Sheeting and bracing ordered left in place is paid for under 504.

Disinfection. If a portion of the excavation consists of decomposed or obnoxious material, thoroughly and satisfactorily disinfect or deodorize the objectionable material where consideration of the health, safety or convenience of the public, or the workers requires such action, or when so directed by the Engineer.

603.051 Tunneling. Construct sewer tunnels only when tunneling is shown on the Plans. Unless so indicated, do not tunnel except by written permission or order obtained from the Engineer before beginning the tunneling work. The City reserves the right to rescind such order or permit at any time during the progress of the work. All of the details of tunnel construction are subject at all times to the approval of the Engineer.

Conform the length of open tunnel at any time to the limits shown on the Plans or determined by the Engineer. Do not commence excavation for tunneling until lumber for sheeting and bracing, or liner plates, have been delivered to the work site. The liner plate diameter shown on the Plans has been determined to permit a maximum mining deviation of three inches (75 mm) from true line and grade. Correct any deviation greater than three inches (75 mm) by reaming, so that the pipe may be laid to true line and grade in the tunnel.

Tap one plate in each course of liner plates for a two-inch (50 mm) grout nipple closed by a screw plug. Stagger grout nipples circumferentially. Grout as necessary to back up liner plates and fill voids. Carry out all grouting as directed by the Engineer.

Construct tunnels in strict conformity with the details shown on the Plans or approved by the Engineer. Keep the width or height of the tunnel a minimum of 54 inches (1.4 m). Firmly hold the sides and roof of the tunnel in place by such sheeting and timbering or liner plates as may be required to fully protect the structures and the workers, and prevent settlement of pavements, walks, curbs, buildings, or other structures. If at any time the City so orders, install additional sheeting, bracing or other supports as the Engineer may consider necessary, but compliance with such orders or failure on the part of the City to issue such orders in no case releases the Contractor from liability for damages resulting from weak or insufficient supports, nor responsibility for protecting The Work and adjoining property from damage. Immediately and compactly fill voids between the tunnel lining and top and sides of the excavation with suitable material in a satisfactory manner. Wedge sheeting boards tightly against the top and sides of the excavation. The haphazard sheeting and bracing of tunnel walls and roof is not permitted. Keep the completed tunnel lining as near as practicable to the working face and at no time more than six feet (2 m) from the face of the tunnel. Keep the face sheeted and braced and the main sheeting ahead of the excavation when soft or running material is encountered in excavation. Under such conditions, it may be necessary to install liner plates with the use of a needle beam. Under extreme conditions, it may be necessary for the Contractor to furnish and use a tunnel shield.

Leave in place the liner plates or sheeting and bracing of all tunnels without extra compensation.

Ventilate all tunnels adequately and light sufficiently to insure proper construction and inspections.

Backfill tunnel entirely with concrete containing a maximum of 12 ft³ (0.34 m³) of aggregate per sack of cement, mixed to a zero slump and well compacted after placing. Use a minimum of three sacks of cement per cubic yard (4 sacks per m³) of concrete. Ram the top portion of the concrete backfill tightly against the top and sides of the tunnel lining.

Payment for sewers constructed in tunnel is made in accordance with the provisions of the pertinent 603 Conduit item, and in addition, the price bid per linear foot covers and includes furnishing and placing sheeting and bracing or liner plates, tunnel shafts, and furnishing and placing concrete for tunnel backfill.

Add:

603.059 Video Taping of installed Sewers. This item shall be used for verifying the integrity and water tightness of the final installed main line sewers following the leakage and deflection testing. All storm, sanitary and combined main line sewers shall be video recorded after all backfill and restoration work has been completed. The videos shall be PACP compliant, and the submittals must adhere to MSD/SMU requirements.

603.06 Bedding.

Conform the conduit bedding to one of the classes specified. When no bedding class is specified, conform the conduit bedding to Class B.

Class A. Bedding - consists of a continuous concrete cradle conforming to the plan details.

Class B. Bedding - consists of a bed of granular material having thickness as shown on Standard Drawing Acc. No. 49032.

Shape the layer of bedding material to fit the conduit for at least ten percent of the vertical diameter of the conduit and shape recesses to receive the bell of bell-and-spigot pipe.

603.07 Laying Conduit. Lay the conduit in the center of the trench starting at the outlet end with the bell or groove-end laid upgrade. Ensure that the conduit is in contact with the bedding throughout its full length such that line and grade is maintained. Lay metal conduits according to one of the following methods:

- A. If the seam is longitudinally either riveted or welded, place the seam or weld at the spring line.
- B. If the metal pipe is fabricated helically (having a continuous seam running around the outside of the pipe), arrange the corrugations so the helix angle or twist is rotating downstream in the direction of the flow to increase hydraulic performance.

Maintain flows at all times until the new facilities are completed and in service. Maintain the flows through existing facilities to be replaced unless a temporary bypass conduit is used.

Construct the inlet and outlet ends of all conduit runs with pipe ends as normally fabricated by the manufacturer. If field cutting is necessary, locate the cut end at an interior joint within the run and provide a cradle, collar, or band to ensure a stable joint.

Construct a concrete collar on the last joint if field cutting is necessary to meet a structure or headwall.

Erect 707.03, 707.15, 707.23, and 707.25 conduits according to 522.03. Where two plate thicknesses are specified, locate the thicker plates at the bottom and corner plates in pipe-arch structures, and the bottom row, if centered, or bottom two rows, if not centered, in round structures.

Set the 706.051 units on the concrete footing shown on the plans. Unless otherwise shown on the plans, provide a 3-inch (75 mm) deep by 14-inch (350 mm) wide keyway in the center of the footing. Place the units in a 1/2-inch (13 mm) bed of mortar. If proper line and grade of the structure cannot be maintained on the bed of mortar, set the units on 5 X 5-inch (125 X 125 mm) masonite or steel shims. Fill the entire keyway joint with mortar.

Set the 706.052 units on the concrete footing shown on the plans. Unless otherwise shown on the plans, provide a 3-inch (75 mm) deep by 14-inch (350 mm) wide keyway in the center of the footing. Place the units on 5 X 5-inch (125 X 125 mm) masonite or steel shims to provide a minimum 1/2-inch (13 mm) gap between the footing and bottom of the unit's bottom leg. Fill the entire keyway joint with mortar.

If reinforced concrete pipe has elliptical reinforcing, the top and bottom of the pipe are clearly marked on the pipe. Handle and place reinforced concrete pipe with elliptical reinforcement and reinforced concrete horizontal elliptical pipe with single cage reinforcement with the reinforcement markings along a vertical plane as marked on the pipe. Handle and place reinforced concrete pipe with auxiliary supports (S-stirrups) with the centerline of the auxiliary support system (S-stirrups) in a vertical plane as marked on the pipe.

For 706.05, 706.051, or 706.052 structures fill the lifting devices with mortar. Cover the exterior of the lifting devices with joint-wrap material if outside the limits of the membrane waterproofing. Use joint-wrap with a minimum width of 9 inches (225 mm). Use only lifting devices that do not require a hole through the structure.

For all 707 conduit, use only lifting devices that do not require a hole through the structure.

Immediately after placing conduit, construct the end treatments at both the outlet and inlet ends. These end treatments include headwalls, concrete riprap, rock channel protection, sod or other erosion control items.

Additional Notes:

Lay the lower segment of the conduit so that it is in full contact with the shaped bedding throughout its full length. Orient longitudinal laps or seams to the sides in metal conduits. Lap the circumferential seams on the inside of the pipe in the direction of flow.

Begin and end all Type A conduits with pipe ends as normally fabricated by the Manufacturer. If field cutting is found to be necessary, locate the cut end at an interior joint and provide a cradle, collar, or band to assure a stable joint.

Erect 707.03 structural plate corrugated steel structures in accordance with the requirements of 522.03.

Place 706.02 reinforced concrete pipe with elliptical reinforcement and 706.04 reinforced concrete horizontal elliptical pipe with single cage reinforcement, with the reinforcement markings along a vertical plane. Place 706.03 reinforced concrete pipe with auxiliary supports along the centerline of the auxiliary support system, in a vertical plane.

Where called for on the plan, encase conduits with specified thickness of Class QC1 concrete meeting the requirements of 511. Include furnishing and placing the concrete encasement and any forming and/or additional excavation required in the unit price bid for the conduit to which it applies.

Lay pipe in a dry trench. Lay pipe only when the Inspector is present.

Curves having a radius of ten or more times the internal diameter of the pipe for sewers 30-inch (760 mm) and larger may be built of radius pipe cast to fit the curve. The center of the first radius pipe must come within one foot (305 mm) of the point of curvature even if it requires the cutting of pipe.

Conduct operations so as to maintain at all times sewer flows through existing facilities to be replaced until new facilities are completed and placed in use.

603.08 Joining Conduit. Join the conduit sections so that the ends are fully entered and the inner surfaces are flush and even.

Provide water-tight joints for all types of conduit, except as noted below. Provide seal with resilient and flexible compression joints, or approved equal, as determined by the Director. Joint seals shall meet ASTM C-443 and C-361. Bituminous pipe joint filler is not permitted.

Where Aluminized Type 2, corrugated metal pipe is permitted to be used for driveway culvert, provide coupling bands having corrugations matching those of the pipe ends.

Type E Conduits have open joints.

Remove all dirt or cement from the inside of the pipe and leave joints smooth after placement is complete. Test to insure proper alignment and grade with a straight edge before placing if two or more joints are jointed and sealed into units. Use push-on type joints; Tyton, Super Bell-tite, or approved equal when ductile iron pipe is used for gravity sewers.

Use mechanical joints when ductile iron pipe is used for force mains or pressure sewers.

Follow specification 706.11 or 706.12 for resilient and flexible gaskets.

Protect completed joints against rapid drying by suitable covering material when Portland cement mixtures are used.

Inspection of the conduit is required before any backfill is placed. Re-lay or replace any pipe found to be out of alignment, unduly settled, or damaged.

603.09 Exterior Coatings and Membrane Waterproofing. Apply waterproofing to 707.03, 707.15, 707.23, and 707.25 conduits with less than eight feet of cover by one of the following methods.

A. Coat the exterior of the conduit above the limits of the bedding and within the limits of backfill. Ensure that all plate seams and bolts are thoroughly sealed. The coating material and application shall conform to AASHTO M 243. Allow asphalt mastic material to dry 48 hours and tar base material to dry 28 hours before placing the conduit backfill. Rib stiffeners do not need to be coated.

B. Construct Buried Liner Waterproofing Membrane protection in the fill per the manufacturer's recommendations. The Buried Liner Waterproofing Membrane protection will be a seamless continuous sheet placed over the conduit and extend at least 10 feet (3.3m) outside of the paved shoulder and for the width of the trench.

For 707.03, 707.15, 707.23, and 707.25 conduits, coat the exterior of the conduit above the limits of the bedding and within the limits of backfill. Ensure that all plate seams and bolts are thoroughly sealed. The coating material and application shall conform to AASHTO M 243. Allow asphalt mastic material to dry 48 hours and tar base material to dry 28 hours before placing the conduit backfill. Rib stiffeners do not need to be coated.

603.10 Backfilling. Place backfill to the limits described and according to the compaction requirements. Place the backfill in the trench and embankment outside the trench uniformly on both sides of the conduit for all conduit installations.

A. General. The Contractor may operate small compaction equipment with less than a total weight of 1 ton (0.9 metric ton) over the conduit to compact the backfill. Do not use hoe packs on top of the conduit until 2 feet (0.6 m) of backfill is compacted on top of the conduit. The Contractor may operate compaction equipment with less than a total weight of 8 tons (7 metric tons), but more than 1 ton (0.9 metric ton), over the conduit after placing and compacting 2 feet (0.6 m) of backfill. Do not operate equipment with a total weight of 8 tons (7 metric tons) or more, until placing and compacting a cover of 4 feet (1.2 m) over the top of the conduit. The above restrictions apply when working within one span on each side of the conduit, or 6 feet (1.8 m), whichever is less. As shown on the plans, encase conduits with the specified thickness of Class QC1 concrete.

B. Long Span.

1.

For long span structures in cut, place and compact structural backfill over the top of the section to a minimum depth 4 feet (1.2 m) or to the subgrade elevation whichever is less and for a width of 2 feet (0.6 m) on each side of the section. Use soil, granular embankment, or structural backfill to construct the adjacent embankment and for the remaining depth to the subgrade. Construct the adjacent material according to Item 203.

2.

For long span structures in fill, place and compact structural backfill over the top of the section to a minimum depth of 2 feet (0.6 m) or to the subgrade elevation whichever is less and for a width of 2 feet (0.6 m) on each side of the section. Use soil, granular embankment, or structural backfill to construct the adjacent embankment and for the remaining depth to the subgrade. Construct the adjacent material according to Item 203.

C. Type A and B. Backfill Types A and B conduits except for long span structures as follows:

1.

In

a cut situation, place and compact structural backfill above the bedding for the full depth of the trench. Within the trench and more than 4 feet (1.2 m) above the top of the conduit, if the trench can accommodate compaction equipment, the Contractor may construct Item 203 Embankment. For plastic pipe with an ID 8 inch (200 mm) or less, place and compact structural backfill above the bedding for the full depth of the trench.

2.

In

a fill situation, place and compact structural backfill above the bedding for the full depth of the trench specified in 603.05.B of this Supplement. Above these limits, uniformly place the lesser of one pipe span or 4 feet (1.2 m) of structural backfill on each side of the conduit and to a depth of 2 feet (0.6 m) above the top of the conduit. Construct the embankment outside the limits of the backfill. For plastic pipe with an ID 8 inch (200 mm) or less, place and compact structural backfill above the bedding for the full depth of the trench.

D. Type C and D. Backfill Type C and D conduits as follows:

1.

In

a cut situation, for plastic pipe, place and compact structural backfill above the bedding and to 12 inches (300 mm) over the top of the pipe. All other conduit material types place and compact backfill. For plastic pipe with an ID 8 inch (200 mm) or less, place and compact structural backfill above the bedding for the full depth of the trench.

2.

In

a fill situation, for plastic pipe, place and compact structural backfill above the bedding for the full depth of the trench specified in 603.05.B of this Supplement. Above these limits, uniformly place the lesser of one pipe span or 4 feet (1.2 m) of structural backfill on each side of the conduit and vertically to the top of the conduit. Then place for a depth of 12 inches (300 mm) structural backfill over the top of the pipe equal to the trench width centered on the pipe center line. Construct the embankment outside the limits of the backfill. All other conduit material types place and compact backfill. For plastic pipe with an ID 8 inch (200 mm) or less, place and compact structural backfill above the bedding for the full depth of the trench.

E. Type E. Place and compact backfill above the bedding to a height equal to two-thirds of the conduit rise then place and lightly compact backfill for a depth of 12 inches (0.3 m) above the pipe. Place no stones larger than 4 inches (100 mm) that will be part of the embankment in contact with the pipe.

F. Type F. Place and compact backfill above the bedding. Backfill Type F conduits for underdrain outlets according to 605.03.C.

Additional Notes:

Backfilling covers the replacing of the excavated materials after the sewers and other structures have been built, and the proper grading and shaping of the surface of the backfill. Do not backfill over completed sewers and structures until they have been inspected and approved. Do not backfill without permission from the Engineer. Backfill pipe sewers immediately after they have been inspected and approved. Prosecute backfilling operation as The Work progresses and keep completed as near to the end of the completed sewer as practicable.

Rubbish, muck, or other unsuitable materials will not be permitted for backfilling material. Do not use stones and shale exceeding one-half cubic foot (0.0034 m³) in volume in the backfill and separate stones and shale that are in the backfill by at least six inches (150 mm) of earth.

Do not use fill material consisting of rocks, frozen lumps, foreign matter and particles in excess of three inches (75 mm) in size when corrugated metal pipe is used. Local site material is adequate if sufficiently compacted at controlled moisture content. Do not use highly plastic silts and clays, organic silts or peats as backfill materials. Place backfill material below the haunches of the pipe and tamp to the specified density. Place an additional six to eight inch (150 mm to 200 mm) layer on each side of the pipe and compact. Backfill all conduits, except Type E, evenly on both sides of the pipe and to a minimum depth of one foot (305 mm) above the pipe for the full width of the trench with granular material placed in layers and pneumatically tamped. In placing and tamping the initial backfill around the pipe sewer, exercise care so as to not disturb the line and grade of the pipe. Hold stepping on or working over pipe sewers to an absolute minimum until they have been covered with the initial backfill.

When the top of the trench is above the top of a Type A, Type B, Type H, or Type I conduit, use granular backfill material above the initial backfill, and compact it to the top of the trench in layers not to exceed four inches (100 mm) in thickness with mechanical tampers. Use Controlled Low Strength Material (CLSM) above the initial granular backfill to the top of the trench when:

1. The trench is located anywhere in the existing or proposed Right-of-Way.
2. Any part of the trench is within two feet (610 mm) of the edge of the future or proposed Right-of-Way; and
3. In crossings of street pavement or driveway extending at the angle of repose, but at least two feet (610 mm) beyond the street or driveway pavement.

For areas outside these limits, water may be used to compact granular material if satisfactory drainage is provided for the free water. When compacting with water, place the granular material in layers not exceeding 12 inches (305 mm) loose depth. Saturate each layer thoroughly with water by flooding or jetting. In lieu of the above requirement for backfilling the full depth of the trench with granular material, backfill portions of deep trenches more than four

feet (1.2 m) above the top of the conduit with suitable soil or granular embankment material, provided that such portions of the trench are sufficiently wide to accommodate the use of heavy compaction equipment. Meet the requirements of 203 pertaining to embankment construction for such equipment.

Place and compact proper embankment material for a width on each side of the conduit, equal to at least twice the diameter of the conduit, or 12 feet (3 m), whichever is less, and for a minimum depth of three feet (914 mm) over the top of the conduit when the top of a Type A or Type B conduit is above the top of the trench and is not in a proposed embankment. Place granular material one diameter or four feet (1.2 m), whichever is less, on each side of the conduit. Compact in layers not exceeding four inches (100 mm) in thickness with mechanical tampers. Place the remainder of the embankment material in accordance with the requirements of 203.

Follow the procedure outlined above when the top of a Type C, Type D, Type F or Type G conduit is above the top of the trench and is not in a proposed embankment, except that granular material will not be required.

Use suitable soil or granular material placed in layers not exceeding four inches (100 mm) in thickness, and compact with mechanical tampers above the initial backfill for Type D, Type F and Type G conduits. Compact the soil as required by 203.

Use suitable soil or granular material above the initial backfill for Type C conduit. Consolidate by thoroughly jetting with water. Consolidate trenches over 14 feet (4.3 m) in depth by jetting in two equal layers.

For jetting other than granular material, insert a hose not smaller than 1-1/2 inch (40 mm) in diameter and a nozzle not smaller than one inch (25 mm) diameter and not shorter than 2/3 the depth of the trench carrying water at a minimum pressure of 40 pounds per square inch (300 KPa) into the backfill in a uniform pattern to obtain maximum consolidation. After the final jetting of the trench, leave the backfill to settle and to permit drainage of impounded water. Include a water removal system, either natural or mechanical, in the typical jetting procedure. Place at intervals not exceeding 500 linear feet (152.4 m) of trench. Raise settled trench surfaces to grade by filling with approved fill material and compacting to a density equal to that of adjacent ground.

Use suitable granular material to backfill above the bedding for Type E conduits. Compact with mechanical tampers. Tamp solidly under and around the pipe to a height above the flow line, equal to two-thirds of the diameter by the use of proper tools. Place the backfill to a depth of 12 inches (305 mm) above the top of the pipe carefully with shovels. Do not dump or shove directly into the trench. Do not use stones larger than four inches (100 mm) in diameter in this part of the backfill. If the granular material, in the judgment of the Engineer, is of a composition such that it will enter the joints of the pipe, wrap the joints with strips of tarred paper or tarred burlap, four inches (100 mm) in width. Pack backfill material around the paper or burlap to prevent its displacement. The above operation will generate no additional compensation for the Contractor.

Construct a uniform embankment over the sewer to a minimum depth of three feet (914 mm) above the crown, when the crown of the sewer is less than three feet (914 mm) below the ground surface. Excess excavated material may be used for this purpose. If there is not enough excess material, the Contractor shall furnish additional approved material without cost to the City.

Grade the surface of all backfill neatly and evenly to conform to the existing ground.

Place sufficient backfill to provide ample support for the sides of the excavation as directed by the Engineer before removing sheeting and bracing. Backfill with suitable material any cavities and voids exposed by, and resulting from, the removal of sheeting.

Do not operate heavy earth moving and compaction equipment closer than one pipe diameter, or six feet (1.8 m), whichever is greater, on each side of the conduit until placing and properly compacting a cover of four feet (1.2 m) over the top of the conduit. Lightweight dozers and graders may be operated over culverts having two feet (610 mm) of compacted cover.

Include payment for backfilling in the unit price bid for various 603 items.

603.11 Placement and Compaction Requirements. Place soil, granular embankment, or Structural Backfill Type 1 or 2 in lifts not to exceed 8 inches (200 mm). The Department will perform all compaction testing according to Supplement 1015. The compaction requirements per material type are as follows:

- A. For soil embankment, compact each lift until 96 percent of AASHTO T 99 is achieved.
- B. For granular embankment and Structural Backfill, Type 1 or 2, compact each lift of material according to 603.11.E of this Supplement using mechanical devices, hoe packs, jumping jacks, hand devices, vibrating plates, or other equipment that meets the restrictions in 603.10. Provide compaction equipment that compacts the material under the haunch of the pipe. If the compaction equipment cannot fully compact the material under the haunch, supplement the compaction equipment by using shovel slicing, spud bars, or mechanical spud bars to compact the material under the haunch of the pipe. Use shovel slicing and spud bars in conjunction with the compaction operations to compact the material and to manipulate the material under the haunch of the pipe.
- C. For Structural Backfill Type 2, compact each lift of material according to 603.11.E of this Supplement using flood compaction or mechanical devices, hoe packs, jumping jacks, hand devices, vibrating plates, or other equipment that meets the restrictions in 603.10. Provide compaction equipment that compacts the material under the haunch of the pipe. If the compaction equipment cannot fully compact the material under the haunch, supplement the compaction equipment by using shovel slicing, spud bars, or mechanical spud bars to compact the material under the haunch of the pipe. Use shovel slicing and spud bars in conjunction with the compaction operations to compact the material and to manipulate the material under the haunch of the pipe.
- D. Place Structural Backfill Type 3 in layers not to exceed 12 inches (300 mm) loose depth. Vibrate, tamp, or compact to approximately 85 percent of the original layer thickness.

E. At the beginning of the work, construct a test section in the conduit trench. The Engineer will use at least 96 percent of the test section maximum dry density for acceptance of the production areas. Use at least the same number of passes or compactive effort used to construct the test section to compact the production areas. Use compaction equipment with a total weight or centrifugal force of at least 1/2 ton (0.5 metric tons). Supply the manufacture's specification for the compaction equipment. Except when using a hoe pack, use at least six passes with the compaction equipment in the production areas.

The Engineer may reduce the minimum passes if the passes are detrimental to compaction.

Construct a new test section if the pipe type, bedding material, backfill material, or trench conditions change.

F. If using trench boxes with either Type A or B conduits, configure the trench box so that the bedding and backfill material is compacted directly against the trench walls.

G. The Engineer may adjust the lift thickness to obtain the required compaction, fill all the voids, achieve the proper seating of the backfill material, and achieve the stability of the backfill material and the pipe. Do not use equipment or methods that compromise the structural integrity of the pipe.

603.12 Clearing Site and Restoring Damaged Surfaces. Immediately after completion of the placing and compacting of the backfill remove and dispose of all surplus material according to 603.01 of this Supplement and clear the site and restore all required surfaces.

Additional Notes:

Immediately remove and dispose of all surplus materials, including dirt and rubbish, after the backfilling has been completed, as prescribed in 105.16 and 105.17. Unless otherwise called for on the plans, replace all pavement, sidewalks, sod or other surfaces disturbed, to a condition equal to or better than that existing before the work was started, or as specified in the "Street Restoration Book", furnishing all materials, labor, equipment, etc.

Perform the work where construction crosses private property in conformity with all agreements between the City and the owners. The Contractor is presumed to have examined these agreements before submitting the Proposal. Whether or not such an agreement exists, replace or restore in a good and professional manner, all property removed, damaged, or destroyed in accordance with the following provisions:

A. Fulfill all work or requirements as noted on the Plans or called for in the Special or Detail Provisions, or the General Notes.

B. Replace or restore all fences, walks, driveways, utility or sewer lines, buildings or other structures removed, damaged or destroyed. Protect, replace, or restore all trees, shrubs, bushes, and other landscaping improvements, except where noted otherwise on the plans. Take

into consideration existing shrubs or hedges crossing a permanent right-of-way or fence. Restore these as provided in the first sentence of this paragraph.

C. Where the work is in an area maintained as a lawn, garden, play field, fairway, etc., remove the top soil and keep separate. For restoration, grade the surface of the area disturbed. Remove any stones, harrow, and cover with a minimum of four inches (100 mm) of acceptable topsoil. Hand rake and fine grade the topsoil then restore with similar cover vegetation.

D. Where the work is in an area such as a pasture, meadow, or cultivated field, remove the top soil and keep separate. For restoration, grade the surface of the area disturbed, remove any stones, harrow, and replace topsoil.

E. When the work is in a ravine or other rough terrain, leave the premises in a neat and orderly condition. Remove rubbish, construction materials and equipment. Grade, remove, or level off surplus excavation.

F. Perform all work under this item at no additional cost to the City by including it in the price bid for the various items of work.

603.13 Field Paving of New or Existing Pipe. Field pave the bottom of the conduit with concrete as shown on the plans.

For new pipe installations, do not pave until at least 4 feet (1.2 m) of fill is placed on top of the conduit, or the top of subgrade is reached. If the paving is placed before completion of the entire fill, clean any gaps between the conduit and concrete paving, then fill with heated bituminous material conforming to 705.04.

Reinforce the paving with 4 X 4-W1.4 X W1.4 galvanized welded wire fabric (or comparable). Provide a mesh with a width 4 inches (100 mm) less than the finished paving. Securely fasten the mesh to the conduit near each edge and at the center of the mesh at points not more than 4 feet (1.2 m) apart along the flow line of the culvert. Repair any damage to the galvanizing or other coating material caused by placement or by tack welding. Use wire brushing and paint with zinc rich paint to make the repairs.

For aluminum structural plate, securely fasten the mesh to the circumferential seam bolts with galvanized tie wire. Provide a paving that is 3 inches (75 mm) thick measured from the top of the corrugations of the conduit to a height equal to 1/3 of the rise. Provide galvanized reinforcing steel support chairs beneath the mesh where necessary. Give special care to the mesh during concrete placement. After placing the concrete, strike it off with a template to produce the proper radius, and finish with a float to produce a smooth finish. Cure the concrete according to 451.10.

603.14 Method of Measurement. The Department will measure conduit by the number of feet (meters), measured from center-to-center of appurtenant small structures or between open ends inclusive of lengths of pipe bends and branches. The Department will not deduct for catch basins, inlets, or manholes that are 6 feet (2 m) or less across, measured in the direction of flow. Where the location of an appurtenance or an open end is changed with the approval of the Engineer to accommodate full conduit sections, the Department will

measure the length placed. Conduits placed on slopes steeper than 3:1 or with beveled or skewed ends will be measured along the invert.

When the pay item calls for concrete encasement, payment for furnishing and placing the concrete encasement, and for any additional excavation required shall be included in the unit bid price for the pertinent conduit. When the pay item calls for a new conduit to be field paved, payment for the field paving, including all work and materials necessary for the item, shall be included in the unit bid price for the pertinent conduit.

The Department will measure field paving of existing pipe by the number of feet (meters).

Additional Notes:

Change the location of an appurtenance or an open-end pipe with the approval of the Engineer to accommodate full conduit sections, by measuring the length to the planned location or the changed location, then implementing whichever results in less cost to the City. When repairing a conduit on storm sewers, the length of conduit to be paid for shall be the actual number of linear feet (m) measured from the internal face of the appurtenant structure to the point of connection with the existing conduit. When changing the location of an appurtenance, measure the length of conduit to the internal face of the appurtenance.

The City will pay for video recording of sewers on a lump sum basis for all storm, sanitary or combination main line sewers. All videos must be PACP compliant, and the submittals must adhere to MSD/SMU requirement.

603.15 Basis of Payment. The Department will pay for accepted quantities at the contract prices as follows:

Item	Unit	Description
603	Foot (Meter)	___" (___ mm) Conduit, Type ___
603	Foot (Meter)	___ X___ Conduit, Type ___
603	Foot (Meter)	___" (___ mm) Conduit Reconstructed, Type ___
603	Foot (Meter)	Type ___ Precast Reinforced Concrete Flat Topped Three-Sided Culvert, ___' (___ mm) Span X___' (___ mm) Rise
603	Foot (Meter)	Type ___ Precast Reinforced Concrete Arch Sections, ___' (___ mm) Span X___' (___ mm) Rise
603	Foot (Meter)	___' (___ mm) Rise X___' (___ mm) Span Conduit, Type A Corrugated Steel Box Culvert, ___' (___ mm) Minimum Cover, ___' (___ mm)

603	Foot (Meter)	Maximum Cover ___' (___ mm) Rise X___' (___ mm) Span Conduit, Type ___ Corrugated Aluminum Box Culvert, ___' (___ mm) Minimum Cover, ___' (___ mm)
603	Foot (Meter)	Maximum Cover ___" (___ mm) Conduit, Type ___, with Field Paving of Pipe
603	Foot (Meter)	___" (___ mm) Conduit, Type ___, Field Paving of Existing Pipe
603	Foot (Meter)	Conduit, Type F for underdrain outlets

Additional Notes:

The number of tee branches ordered and accepted will be paid for at the Contract unit prices bid. The video taping of installed sewers, will be paid at the Contract unit price.

Payments will be made under:

Item	Unit	Description
603	Each	T-branches
603.029	Lump Sum	Video Taping of Installed Sewers

Item 604 Manholes, Catch Basins, Inlets, Inspection Wells, Junction Chambers, Precast Reinforced Concrete Outlets, or Monuments

- 604.01 Description**
- 604.02 Materials**
- 604.03 Construction Methods, General**
- 604.04 Excavation and Backfill**
- 604.05 Brick and Block Masonry**
- 604.056 Precast Solid Concrete Block**
- 604.06 Precast Concrete Modular Construction**
- 604.064 Precast Concrete Rings**
- 604.07 Concrete (Cast-In-Place)**
- 604.08 Method of Measurement**
- 604.09 Basis of Payment**

604.01 Description. This work consists of constructing or reconstructing manholes, catch basins, inlets, inspection wells, junction chambers, precast reinforced concrete outlets, or monuments of the type and sizes specified; or adjusting existing castings to grade, as specified.

Use removed or excavated materials in the Work when the material conforms to the specifications; if not, then recycle or dispose of the material according to 105.16 and 105.17.

604.02 Materials. Furnish materials conforming to:

Structure concrete, Class QC1	499, 511
Brick and masonry units	704
Precast reinforced concrete manhole, catch basin, and inlet sections	706.13
Precast reinforced concrete outlet	706.15
Preformed expansion joint fillers	705.03
Epoxy coated reinforcing steel	509.02, 709.00
Cast frames, grates, and covers ...	711.12, 711.13, or 711.14
Welded frames and grates	513.17, 711.01
Steps	711.13, 711.30, or 711.31
Structural backfill, Types 1, 2 and 3.....	703.11
Resilient and flexible gasket joints	706.11
Curing materials.....	705.05, 705.07
Mortar	602
Nonshrink Mortar... ..	705.22

The City will furnish replacement of castings broken and/or needing replacement due to no fault of the Contractor. Obtain replacements at the appropriate City Storage Yard. Include the cost of hauling castings in the unit price bid for this item.

604.03 Construction Methods, General. Construct the specified structures according to the plans. Place inlets, catch basins, inspection wells, junction chambers, monuments, or precast outlets at the locations and elevations shown in the plans according to the standard construction drawings or as directed by the Engineer. Place manhole castings at the elevation and station with offset to the center of the casting or as directed by the Engineer. Place the manhole base at the elevation and station with offset to agree with the pipe station, offset and pipe invert elevation according to the standard construction drawings or as directed by the Engineer. Use flat slab top manholes, except where the manhole is located within the street, as shown on the standard construction drawing. Do not remove the flat slab top manhole lifting devices.

There will be no additional payment for any inlets or manholes where the structure elevation is changed four feet (1.2 m) or less. If the structure elevation is changed more than four feet (1.2 m), compensation or deductions for the work involved, whether increased or decreased, will be paid for under 602. Where it is necessary to construct catch basins or inlets over four feet (1.2 m) in depth, changes in the depth of walls will be paid or credited for under 602.

Thoroughly mortar with a flush mortar joint the underdrain outlet pipe to the precast reinforced concrete outlet. Furnish and place lateral sewer connections including drops and leads except pipe included in Item 603 in this Supplement.

Locate or cut conduits as shown on the standard construction drawings so they do not protrude inside the structure walls.

Take adequate precautions to prevent structure concrete or mortar cement from freezing. Preheat the brick, concrete block, or precast concrete structure throughout the entire mass to a temperature between 50 to 80 °F (10 to 27 °C) before placing mortar if the ambient temperature is 40 °F (4 °C) or less.

Set iron frames, tops, and covers of the type shown on the plans in a mortar bed with a flush mortar joint.

Prevent earth or debris resulting from construction operations from entering the manholes, catch basins, junction chamber, inlets, and precast reinforced concrete outlets. Remove any debris.

A. Reconstruction to grade

1. Carefully remove and clean the existing castings.
2. Remove the existing walls of manholes down to the spring line or below as necessary.
3. Remove existing walls of catch basins and inlets below the window openings, grates, or any points of wall failure.
4. Using the salvaged casting, reconstruct the structure to the new grade, conforming as nearly as practicable to the existing dimension and type of construction.

B. Adjustment to grade

1. Carefully remove and clean the existing frame, adjust the height of supporting walls, and reset the existing frame in a bed of concrete mortar or structure concrete to the new grade.
2. Carefully remove the existing cover or grate and install a casting or an acceptable adjusting device on file at the Laboratory or an adjusting device approved by the Engineer to the new grade and install per the manufacturer's recommendations.

Supply all castings. Submit as directed by the Engineer. In addition to other requirements, provide only bicycle safe-type inlet castings.

Properly slope and set castings in conformity with the existing pavement surface, or so the new pavement and curbs may be constructed as shown on the Standard Drawings.

Fasten manhole frames to the manhole using at least four stainless steel anchors-3/4" x 4" or 4-3/4" x 3/4" (20 x 125 mm) expansion bolts.

Furnish grills for wing wall inlets. Fabricate from single refined wrought iron bars (ASTM A-189) as shown on the Standard Drawings. Place two coats of good quality black asphaltic paint on the grills. Apply one coat immediately after fabrication, and the other coat after installation.

Replace any existing walks disturbed during the construction of manholes, catch basins, and inlets at no additional cost to the City and in such manner as to conform in all details to their original construction unless the building of new walk is included in the work.

All connections for existing sewers, including drops and leads, except pipe included in 603, are considered a part of manholes, inlets and catch basins. Furnish and place six inch or eight inch (150 or 200 mm) drain tile, 706.07 or 706.09 in manholes, catch basins, and inlets for sub-grade drainage, where and as directed by the Engineer. Consider said tile a part of all manholes, inlets and catch basins.

Use Butyl mastic seals at manhole joints and at adjusting rings. See Acc. No. 49037.

When reconstruction of a manhole is specified, remove the domed section of the existing manhole and reconstruct the manhole to the new grade, conforming as nearly as practicable to the existing dimension and type of construction. Reuse the salvaged castings provided they are the latest version castings or use new castings.

When remodeling the bottom of existing manholes is specified, construct a new manhole invert to facilitate a change in pipe size, slope, elevations or sewer alignment. Construct the new bottom of brick or formed concrete masonry, as shown on Standard Drawing Acc. No. 49004. Brick Masonry is not permitted for concrete manhole construction.

Remove and haul away any construction material or other debris that may drop into the inlet chamber or manhole during Contractor's operation. Do not permit or cause any debris or construction material to enter the main sewer system. No separate payment shall be made for this work; therefore, include all costs in the price bid for these items.

604.04 Excavation and Backfill. Excavate to dimensions that provide ample room for construction.

Remove any obstruction necessary at no additional cost to the City.

Take all necessary precautions to protect the work already completed and the adjacent property. Should it be necessary to resort to blasting, be responsible for any and all damage to the work or to adjacent property. Before blasting, apply, pay for and receive for a permit from the City Engineer.

If the material found at grade is not suitable for foundation, excavate to a further depth and fill with suitable material. Payment shall be as provided in 210 and 211.

The Engineer may adjust the proposed locations of manholes, catch basins, and inlets during construction. If the flow line is changed more than one foot (305 mm) horizontally,

provide for compensation or deductions under 109.05. The City Engineer must review and approve any changes in such facility locations before deviating from plans.

The backfilling shall follow the completion of the work as closely as the type of construction will permit. Take special care not to disturb the work. Use Controlled Low Strength Material (see Hamcin specification) for all backfilling within six feet (2 m) of all manholes and inlets unless otherwise approved by the Engineer.

Backfill excavations in streets which are paved or are to be paved using Controlled Low Strength Materials as specified in 613. Granular fill of the type specified for Type B conduits is prohibited.

Backfill excavations not located within two feet (610 mm) of the street pavement as specified for backfill above the initial backfill for Type C Conduit in 603.10 of this Supplement.

Dispose of all waste surplus from excavation in accordance with 105.16 and 105.17 before laying in the mortar.

604.05 Brick and Block Masonry. Thoroughly wet brick and concrete block masonry units before laying in the mortar, and lay the brick and masonry units with a flush mortar joint.

Take adequate precautions to prevent concrete and mortar from freezing. Do not set brick and masonry units having a temperature of 40 °F (4 °C) or less with mortar until heated. When required, heat to ensure that a temperature of 50 to 80 °F (10 to 27 °C) is obtained throughout the entire mass of the material.

Cure the exposed surfaces of all brick and block masonry by covering with wet burlap for 48 hours or by applying curing membrane according to Item 511.

Form channels in the bottom of manholes as shown on the Standard Drawings or as directed by the Engineer. Line both the channels and benches with vitrified brick or formed concrete masonry. Brick Masonry is not permitted for concrete manholes.

In constructing walls of storm manholes, lay the brick radially in a full bed of mortar with interior joints not more than 1/4 inch (6 mm) wide. Lay every seventh course as stretchers. Lay the intervening courses as headers. As the wall is laid up, anchor the manhole steps in the masonry as shown on the Standard Drawings. Place stubs in the wall of the manhole to accommodate inlet and other pipes entering the manhole. Support these stubs with brick masonry corbelled out from the side of the manhole, as shown on the Standard Drawing. In lieu of this corbelling, the pipe may be supported with brick or concrete masonry extending down to the bottom of the excavation. Dome the upper portion of the manhole as shown on the Standard Drawings. Draw in the walls gradually until the inside diameter is two feet (610 mm). Neatly point up the interior joints and clean the surface of all surplus mortar. Outside joints shall be entirely filled with mortar and the surface plastered with a mortar coat 1/2 inch (12 mm) in thickness. Manhole steps are not required in manholes.

Protect masonry joints from freezing for a period of five days.

Brick masonry is not permitted in junction chambers.

604.056 Precast Solid Concrete Block. Lay concrete blocks as specified for brick masonry under 604.05 of this Supplement. Do not, however, use concrete blocks in construction of manholes and junction chambers.

604.06 Precast Concrete Modular Construction. Furnish precast bases on a compacted structural backfill bed having a minimum thickness of 3 inches (75 mm). Ensure that the structural backfill bed is level and uniformly support the entire area of the base.

After placing the pipe, grout all openings between the pipe and structure less than 4 inches (100 mm) with mortar and grout all openings between the pipe and structure greater than 4 inches (100 mm) with nonshrink mortar. Seal all joints between modules with materials specified in Item 603 for Type A, B, C, D, or F conduit.

Cure median inlets with the same materials and methods specified in 622.07.

The manufacturer of precast modular items must be certified according to Supplement 1073.

604.064 Precast Concrete Rings. Seal joints in precast rings as prescribed under 604.03 of this Supplement.

604.07 Concrete (Cast-In-Place). Place and furnish structure concrete as shown on the plans.

604.08 Method of Measurement. The Department will measure Manholes, Inlets, Catch Basins, Monument Assemblies, Monument Boxes, Reference Monuments, Inspection Wells, Junction Chambers, and Precast Reinforced Concrete Outlets, whether new, reconstructed, or adjusted to grade, by the number of each type of structure complete and accepted.

604.09 Basis of Payment. The Department will pay for accepted quantities at the contract prices as follows:

Item	Unit	Description
604	Each	Manholes
604	Each	Inlets
604	Each	Catch Basins
604	Each	Monument Assemblies
604	Each	Reference Monuments
604	Each	Right-of-Way Monuments
604	Each	Inspection Wells
604	Each	Junction Chambers
604	Each	Manhole, Catch Basin or

604	Each	Inlet Reconstructed to Grade Manhole, Catch Basin, Inlet, or Monument Box Adjusted to Grade
604	Each	Precast Reinforced Concrete Outlet

Additional Item:

The work included in this item, including excavation, backfill, hauling and setting castings, furnishing interceptor inlet castings and grills for wing wall inlets, reinforcing steel, where specified, restoration not included under conduit installation and for other incidentals necessary for completion of the items, shall be paid for at the Contract price, complete in place.

Item	Unit	Description
604	Each	Remodel Bottom of Existing Manholes

Item 608 Walks, Curb Ramps, and Steps

608.01 Description. Add after the words "curb ramps" the words "detectable warning strips".

608.02 Materials. Add:

Base Course Concrete Walk.....	608
Edge Restraint (Concrete Walk).....	608
Bedding and Joint Sand	703.02A
Type "B" Clay Unit Pavers	704.04
Type "C" Cast Iron	712.14
Type "G" Granite.....	712.14
Type "O" Surface Applied Polymer Domes.....	712.14
Type "F" Flat Plate.....	712.14

608.03 Concrete Walks.

A. Excavation. Add:

Saw and trim the existing sidewalk (at a joint) to a neat line wherever the proposed concrete sidewalk adjoins or abuts an existing sidewalk.

C. Placing and Finishing. Replace first paragraph with the following:

Immediately before placing concrete, thoroughly moisten the subgrade. Deposit concrete in a single layer; strike it off with a template. Provide an even and uniform broom finish placed perpendicular to the curb line. Do not plaster the concrete.

In locations such as the Central Business District, Neighborhood Business Districts, and historic Over-the-Rhine and Pendleton neighborhoods, edge first then broom finish for the final finish. Leave no ribbons. In all other locations, broom finish and match adjacent walk edge condition.

Use a 1/4-inch (6 mm) radius edging tool to edge all outside edges and joints. Divide the surface of the walks into equally spaced rectangular blocks at approximately 5-foot (1.5 m) intervals. Saw or form transverse joints to a depth of not less than one-fourth the thickness of the slab and to a width of approximately 1/8 inch (3 mm). Install 1/2-inch (13 mm) thick expansion joint filler between the walk and any fixed structure that extends the full depth of the walk. Install 1-inch (25 mm) thick expansion joint filler between the walk and the back of curb that is on a 250-foot (75 m) or smaller radius, such as at street intersections. Install 1/2-inch thick expansion joint filler at driveways as shown in the City Standard Drawings. Expansion joints shall be provided in sidewalks at such intervals, not exceeding 30 feet, as the Engineer may direct. These expansion joints shall be made of 1/2-inch thick and 5 inch wide preformed material.

Expansion joint filler shall be placed flush with the surface of the walk. Joint filler that is more than 1/4 inch below the sidewalk surface shall be filled with caulk in accordance with Item 639.1- Caulking and Sealant of this Supplement.

Add:

608.031 Clay Paver Sidewalks. Construct clay paver sidewalks as follows:

A.

Descri

ption. This work consists of providing all equipment, labor and material necessary to install new clay pavers, including all related accessories/attachments & hardware, for completion of work according with the construction plans and specifications.

B. Materials. Provide Interlocked Clay Paver Brick meeting the following requirements:

Type: I
Class: SX
Application: PX
Size: 2 1/4" T. x 4" x 8"

Use standard clay pavers and clay pavers with truncated domes at curb ramps from the same manufacturer in accordance with 608.071 Detectable Warning Strip of this Supplement. Pavers must have spacer lugs and chamfered edges. Submit samples for approval.

C. General. All edges of the clay paver installation must be restrained. The type of edge restraint is noted on the plans.

D. Base. Construct the sand laying course as follows:

1. Use only clean, compacted masonry sand for the 1" paver setting bed and the paver joints specified for pedestrian traffic areas in compliance with ASTM C 144.
2. The finished base course shall be approved before the placement of the sand laying course.

3. The sand laying course shall be spread evenly over the areas to be paved and screened to a level that will produce the required 25 mm (1") maximum thickness when the clay pavers have been placed and vibrated.

E. Placing and Finishing. Place brick paver bricks as follows:

1. The paver units shall be laid in the approved pattern.
2. The paver stones shall be laid in such a manner that the desired pattern is maintained and the joints between the stones do not exceed 3 mm. (1/8").
3. The gaps at the edge of the paved surface shall be filled with standard edge pieces or with bricks cut to fit. The bricks shall be cut to a straight even surface without cracks or chips. All cuts to be within 1/16".
4. After final vibrating the surface shall be true to grade and shall not vary by more than 5 mm (1/4") when tested with a 3 m (10') board at any location on the surface.
5. Sand pavers in and brush. Repeat as needed to ensure complete filling of gaps.

608.07 Curb Ramps. Replace second paragraph with the following: Furnish all labor, material and equipment necessary for the placement of detectable warning devices at curb ramps or other walking surfaces, complete and ready for service at the locations shown on the plans. The work includes but is not be limited to: layout, maintenance of pedestrian traffic, saw-cutting, removals, concrete and cement base materials, bedding, surface preparation, surface sealant, and repair of adjoining areas disturbed by the installation of the detectable warning surface.

Type "B" New Detectable Warning installations includes the forming of the recessed space required to accept the new pavers into the concrete ramp as a monolithic placement. See standard drawings, for typical details. Perform the work in accordance with Sections 4.1 and 4.7 of the Americans with Disabilities Act Accessibility Guidelines (ADAAG) as amended through January 1998 and with Section 1108 of the Architectural and Transportation Barriers compliance Board's "Draft Guidelines for Accessible Public Rights-of-Way", dated June 17, 2002 as amended, supplemented and adopted.

Ensure all detectable warning materials conform to ANSI A117.1—1998 Specifications. Submit manufacturer's certification of compliance with all applicable standards and drawings and/or catalog cutsheets to the City Engineer for approval at least three working days prior to installation. Submit four copies of the Manufacturer's technical data for each manufactured product.

Detectable warning surfaces contrast visually with adjacent walking surfaces either light-on-dark, or dark-on-light. Furnish textured surfaces to provide slip resistance. Submit color samples for approval by the City Engineer at least three working days prior to installation. Color submittals include manufacturer's statement of percentage of visual contrast provided according to ADAAG A4.29.2. Submit three samples made up of actual unit pavers – color and texture required. Include in each set of samples the full range of exposed color and texture that to be expected in the completed work. Brick red is the preferred color of a detectable warning used with a light background. Safety yellow or light granite is the preferred color of a detectable warning used with a dark background. The City Engineer may approve other colors.

Protect unit pavers and aggregate during storage and construction against wetting by rain, snow or ground water and against soilage or intermixture with earth or other types of materials.

A. Types. Material type of detectable warnings includes the following classifications:

Type "B" (Brick) — Pre-Cast clay/ceramic paving bricks.

Type "G" (Granite) — Granite paving blocks.

Type "O" (Overlay) — Surface Applied Polymer Domes.

Type "F" (Fiberglass) — Flat Plates applied to wet concrete.

Type "C" (Cast Iron) — Flat Plates applied to wet concrete.

B. Sub-Base Course. Compact sub-base to 8-1/2 inches (216 mm) below final grade. Provide base course material to bring the sub-base up to the appropriate level.

C. Base Course. The base course consists of five-inch (125 mm) thick plain concrete walk. Construct the top of concrete base course 3-1/2 inches (89 mm) below final grade. Shape the base course to grade and cross section with an allowable local tolerance of 1/4 inch (6 mm). Provide smooth trowelled finish and at least two weep holes at the low points in the depression. Fill weep holes with pea gravel and cover with filter fabric to prevent sand migration out of the depression.

D. Edge Restraint. Restrain Type B detectable warning strip bricks on all edges by six inch thick by nine inch wide (150 mm by 225 mm) cast-in-place concrete walk conforming to the requirements of 608. Do not place expansion joints immediately adjacent to brick pavers or through the edge restraint. Taper the transition between 9 inches (225 mm) thick walk and five inches (150 mm) thick walk over a distance of five inches (150 mm) as shown on the Standard Drawings.

E. Size, Location and Alignment. Detectable warning surfaces extend 24 inches (610 mm) minimum in the direction of travel and the full width of the curb ramp, landing, or blended transition. Locate the detectable warning surface so that the edge nearest the curb line is six inches (150 mm) minimum and eight inches (205 mm) maximum from the face of the curb line. Align the domes on a square grid, in rows parallel and perpendicular to the predominant direction of travel. Do not skew domes diagonally to the direction of travel.

F. Application. Prepare the surface of existing conforming ramps and install the detectable warning devices in accordance with Manufacturer's specifications and in accordance with this specification, or as otherwise specified on the plans. The finished surface is uniformly profiled to completely match the adjoining surfaces without lips, obstructions and drains completely.

If there is a delay of more than 24 hours in installing the pavers, before the depressed base is open to pedestrian traffic, fill the hole with clean stone conforming to ODOT Item 304. Remove all stone prior to placement of the sand bedding course.

Obtain approval of the finished base course before placement of the sand bedding course. Cover the weep holes with filter fabric to prevent migration of sand bedding. Spread the sand bedding evenly over the areas to be paved and screened to a level that will produce the required 2-1/4 inches (56 mm) thickness when the paving bricks have been placed and vibrated. Do not disturb the sand bedding course once it has been screened and leveled.

Lay the paver units in the approved pattern. Lay the bricks in such a manner that the desired pattern is maintained and the joints between the bricks do not exceed 1/8 inch (3 mm). Fill the gaps at the edge of the paved surface with standard edge pieces or cut the bricks to fit. Cut the bricks to a straight even surface without cracks or chips. All cuts to be within 1/16 inch (1.5 mm).

Protect the paving bricks with mechanical protection (carpet, rubber material, etc.) and vibrate to their final level by two or three passes of a vibrating plate compactor. After the first vibration, brush sand containing at least 30 percent 1/16 inch (1.5 mm) particles over the surface and vibrate it into the joints with additional passes of the plate vibrator so as to completely fill the joints. Sweep the surplus material from the surface and leave the entire site clean. After the final vibrating, test the surface with a four foot (1.2 m) board to verify that the surface is true to grade and does not vary by more than 1/4 inch (6 mm) at any location.

Detectable Warning, Type B Retrofit. To install Type "B" Retrofit Detectable Warnings, remove existing sidewalk, replace with no less than the lower three feet of concrete curb ramp and install a new concrete ramp with recess to allow for the new bricks and sand bedding per 608.07. See standard drawings, for typical details.

Detectable Warning, Type O. Install Type "O" Detectable Warning installations, on pre-existing concrete curb ramp installations conforming to ADAAG. Do not use on new construction. Install the detectable warnings in accordance with the Manufacturer's installation instructions.

Detectable Warning, Type F and Type C. Install Type "F" and Type "C" Detectable Warning installations in new, wet concrete in accordance with the Manufacturer's published installation instructions.

G. Warranty/Guaranty. Provide a warranty that the application by the Manufacturer to last no less than five years without losing more than two percent of the truncated domes. Also provide a warranty by the Manufacturer for five years against fading, chipping, peeling, cracking, or loss of original shade due to sunlight, salt or exposure to weathering.

608.08 Method of Measurement. Add after the third paragraph:

The City will measure the actual square feet of detectable warning devices, furnished and in place, complete and accepted measured from center-to-center of the outer-most domes parallel and perpendicular to the ramp centerline, with both measurements each increased by two inches (50 mm) and then multiplied together. Round the square footage (square meter) calculation to the nearest one-tenth square foot (0.1 m²). Complete this item and include all work necessary to provide a complete and useable detectable warning device.

The City will measure Clay Paver Sidewalk by the number of square feet (square meters) of finished surface, complete in place.

608.09 Basis of Payment. Add:

Item	Unit	Description
608	Square Foot	Detectable Warning, Type "B" (Square Meter)
608	Square Foot (Square Meter)	Detectable Warning, Type "B" Retrofit
608	Square Foot (Square Meter)	Detectable Warning, Type "O"
608	Square Foot (Square Meter)	Detectable Warning, Type "F"
608	Square Foot (Square Meter)	Detectable Warning, Type "C"

Additionally, for the work of clay paver sidewalks, payment includes construction of the sand laying course and furnishing and installing the paver bricks and all related accessories/attachments and hardware required to complete the installation as specified.

Item	Unit	Description
608	Square Foot (Square Meter)	Clay Paver Sidewalk

Item 609 Curbing, Concrete Medians, and Traffic Islands

609.01 Description

Add:

Construct curbing in strict accordance with the following Standard Drawings on file in the City Engineer's office, which show the details of construction for the following various types of curbs.

- Type A-1, Asphaltic Concrete Curb (Acc. No. 21429)
- Type B-1, B-2 and B-3, Concrete Curbs Integral with Concrete Base (Acc. No. 21431)
- Type L-1, Standard Lug Concrete Curb (Acc. No. 21430)
- Type P-1, P-2 and P-3, Concrete Curb Integral with Concrete Pav't. (Acc. No. 21432)
- Type P-4 and R-2, Standard Concrete Combined Curb and Gutter (Acc. No. 21433)
- Type R-1, Standard Conc. Roll Curb Integral with Concrete Pav't. (Acc. No. 21434)
- Type S-1, S-2 and S-3, Standard Separate Concrete Curbs (Acc. No. 21435)

609.04 Cast-in-Place Concrete Curb and Combination Curb and Gutter. Add:

The finished curb form must measure precisely to the curb dimensions. Forms of greater or lesser height will not be permitted. Include backfill, compaction, and soil renovation consistent with Item 654 and Sodding, consistent with Item 660 for restoration adjacent to the curb. Adhere to the provisions of Item 660.09 Watering.

609.08 Basis of Payment. Add at the end of the first sentence of this section:

“regardless of whether the curb depth is of uniform or varying height.”

Item	Unit	Description
609	Foot (Meter)	Concrete Curb Repair, Type R-2 (Acc. No. 21511)
609	Foot (Meter)	Concrete Curb Repair, Type P-4 (Acc. No. 21511)
609	Foot (Meter)	Concrete Curb, Type S-1 (Acc. No. 21435)
609	Foot (Meter)	Concrete Curb, Type L-1 (Acc. No. 21430)
609	Foot (Meter)	Concrete Combined Curb & Gutter (Acc. No. 21433)

Add:

Item 611 Pipe Culverts, Sewers, Drains, and Drainage Structures

611.01 Description. Delete and replace with the following:

This work consists of constructing conduits, and constructing and reconstructing drainage structures. Perform the work of this item in accordance with Items 603 and 604 of this Supplement.

611.02 through 611.16. Delete these sections and refer to the pertinent sections of Items 603 and 604 in this Supplement.

611.17 Basis of Payment. When utilizing the 611 pay items for ODOT Urban Paving and ODOT LPA projects, add the “As Per Plan” designation onto the pay item description since these items are referring to Item 603 and 604 specifications in this Supplement.

Add:

Item 612 Tree Grates and Guards

612.01 Description. This work consists of furnishing all materials, equipment, and labor necessary to clean and paint tree grates and guards, enlarge tree grates including removing the tree grate, notching the radial spokes, breaking off the unwanted portions, and

resetting the grate, and/or installing a new tree grate or half of a tree grate into an existing tree grate frame. Additionally, it may include adding washed pea gravel, if gravel settling has occurred.

612.02 Materials. Furnish materials conforming to:

Paint	708.03
Cast Iron Tree Grates	711.121
Pea Gravel	703.01 - #8 Gradation

612.03 Painting Tree Grates and Guards.

A. Preparation. Prepare surfaces to be painted in accordance with the paint Manufacturer's published recommendations. Submit six copies of paint technical data, as well as thinning instructions and MSDS to the Engineer at least fourteen days prior to beginning paint preparation work. Deliver materials to the site in their original, unopened containers.

B. Application. Apply paint in accordance with the paint Manufacturer's published recommendations. Paint only surfaces that are clean and dry. Do not apply paint in rain, snow, fog, or mist, or to frosted or ice coated surfaces. Apply materials smoothly, spread or flow on evenly, free from runs, sags, brush marks, or other defects. Treat defective surfaces and sand all surfaces between coats of paint. Allow preceding coat to dry thoroughly before applying succeeding coat. Minimum time between coats is 24 hours, if faces are of uniform texture, color, and sheen.

Thin no coating more than specifically recommended in the Manufacturer's published literature. Use thinner of highest type of those recommended. Do not thin ready-prepared coating without the approval of the Engineer. Use pure, highest quality auxiliary materials, such as linseed oil, shellac, turpentine, etc., approved by the Engineer. Identifying labels must be placed on the material containers.

Apply all coatings by brush or roller unless spray application is specifically named as acceptable in description of required treatment. Thoroughly stir coatings and keep at a uniform consistency during application. Dispose of excess paint, thinner, and/or other auxiliary materials offsite in a lawful manner.

612.04 Enlarging Expandable Tree Grates.

A. Construction. Remove both halves of the tree grate and, using a pneumatic or electric cutting wheel or grinder, notch halfway through the surface of the grate where it is intended to be enlarged. When notching is completed, support useable portion of grate on a solid surface with notched areas approximately one half inch off the edge of solid surface. Strike the unusable portion of the grate with a hammer and fracture each notch separately. After the unusable portion is removed, use a grinder to smooth rough edges. Reinstall grate to original position. Take special care to protect tree and surrounding surface. Any tree or grate damage caused by this work must be corrected or compensated for as determined by the Urban Forest Manager.

612.05 Installing New Tree Grate Into Existing Tree Grate Frame.

- A. Preparation.** Furnish cast iron tree grates conforming to ASTM A-48-83 Class 35 or better, manufactured by Neenah Foundry Company, or approved equal. Furnish pea gravel washed and free of all debris.
- B. Paint and Primer.** Furnish new grates with paint and primer, if indicated on the plans or directed by the Engineer.
- C. Installation.** Backfill to one inch below grate seat with washed pea gravel. Clear all debris from grate seat prior to setting grate. Set grate flush with the top of the frame. Grate halves must be bolted together on the underside when bolt slots are provided. Do not damage the tree. Any tree damage caused by this work must be corrected or compensated for by as determined by the Urban Forest Manager.

612.06 Method of Measurement Tree Grates. The City will measure the number of tree grates and tree guards painted by each half grate. The City will measure enlarging expandable tree grates by each half grate enlarged. The City will measure furnishing and installing tree grates by the number by each half grate installed and accepted, complete.

612.07 Basis of Payment. Payment for the painting of grates and guards is full compensation for all labor, material, and equipment necessary to perform work described above. Payment for the enlarging of the tree grates is full compensation for all labor, material and equipment necessary to perform work described above. Payment for furnishing and installing tree grates is full compensation for all labor, tools, material, and equipment necessary, including proper backfilling for each grate.

Item	Unit	Description
612	Each	Painting Tree Grates and Guards
612	Each	Enlarging Expandable Tree Grates
612	Each	Installing New Tree Grate into Existing Frame

Item 613 Low Strength Mortar Backfill

Delete the contents of this Item and substitute:

Use the current version of the HAMCIN: CLSM – CDF specifications that are on file with the Office of the City Engineer.

Item 614 Maintaining Traffic

614.01 Description. Add at the end of this section:

Keep a copy of these notes available at the site anytime work is in progress.

All subcontractors must adhere to the same MOT (Maintenance of Traffic) requirements as the General Contractor.

614.02 Traffic Facilities. Add after the second sentence in Subsection "A":

Maintain Police and Fire Access at all times.

614.03 Traffic Control General. Add after the first paragraph:

Perform the required work with the maximum safety of, and the least inconvenience to the traveling public and the Contractor. The Engineer must approve any proposed variance from the Maintenance of Traffic notes in advance, in writing. Except as modified below, the requirements for maintaining traffic, as indicated in the "State of Ohio Department of Transportation Construction and Material Specification", Item 614; "The Ohio Manual of Uniform Traffic Control Devices" (OMUTCD or the Ohio Manual), Part 6; and the City of Cincinnati "Traffic Safety Handbook" (Blue Book) current editions, latest revisions and pertinent items of Specifications and proposal shall apply.

To assure maintenance of adequate traffic control at all times, do not install or remove any traffic control devices without the approval of the City Traffic Engineer, his or her designee and the Engineer. Submit a Maintenance of Traffic Plan 14 days prior to the start of construction. The MOT plan is subject to review before implementation. Include a drawing accurately depicting the alignment of the roadway, and indicating all traffic control devices and their alignment, (north direction arrow, street names, travel direction, sign spacing, signs wording, device placement, lane widths, barricades, lights, pavement markings, etc.).

At the Pre-Construction Meeting, submit to the Engineer the name and telephone number of a person(s) who can be contacted 24 hours a day by the City of Cincinnati and all interested Police agencies. This person(s) shall be responsible for replacing and maintaining necessary traffic control devices per the approved traffic control plan.

Add after the last paragraph:

Keep all equipment clean and in proper working condition. Use only retroreflectorized or illuminated signs of the most recent color and type as specified in the Ohio Manual.

The Contractor is required to obtain prior approval from the Engineer for any work on the weekend or nights.

Maintain and keep erect all existing street name signs during construction. When necessary due to construction conflicts or activities, relocate the existing sign, if possible, or remove the existing sign for storage and pick-up by City forces.

Include payment for this work in the lump sum price bid for Item 614 Maintaining Traffic.

Add:

614.031 Notifications. Notify the following, five working days prior to the start of work and any street closure with the approval of the City Traffic Engineer or his or her designee and the Engineer:

- A. Local Police District
- B. Local firehouses
- C. Queen City Metro/SORTA
- D. TANK (for work in the CBD)
- E. Local schools.
- F. Local hospitals
- G. Abutting property owners
- H. Additional contacts as required by the Engineer.

If temporary signs to restrict parking are installed, notify the local Police District 24 hours prior to installation and post the signs at least 14 hours before the parking restriction listed on the signs. Use properly worded temporary signs with legible dates and times.

Contact the Traffic & Road Operations Division Supervisor at 200-5212 or TSB (Traffic Services Bureau) Controller Service Section at 352-4391 or 378-6200 at least one week prior to any grinding or curb repair operations near vehicle loop detectors. Coordinate an acceptable date with them to begin grinding work in order to save the existing loops or to arrange for proper signal operation if the loops must be destroyed. Coordinate with them to ensure that the existing pavement markings are documented and the proposed pavement marking drawing is ready prior to beginning grinding operations and/or paving operations.

614.04 Work Zone Marking Signs. Add after the third paragraph:

C. Erect a ROAD WORK AHEAD sign and a END ROAD WORK sign on permanent mountings on all project streets and all side streets leading into or out of the project area for the length of the project. Mount signs between 100 feet (30.5 m) and 200 feet (61 m) from the project area. These signs are not to be considered replacements for any advanced warning signs used for lane closures.

Remove all signs no later than 15 days after the completion of the project.

614.07 Traffic Maintained. Add after the first paragraph:

Replace any traffic control device that becomes moved or damaged during the duration of the project. Assign a competent person to check the work zone on a daily basis to correct any deficiencies. Make checks before work is to start for the day and continuously throughout the day. Make a final check before leaving the site for the day to assure all devices are in place or, if not needed, are covered, turned or removed from the site. Cover, turn sideways or remove from the site any unnecessary signs when no work is being performed and no roadway hazards are present.

Add after the fifth paragraph:

Use flashing arrow panels for all lane closures. Flashing arrow panels may be required at any time during the job or project by the Right of Way Management Inspector or a Traffic Engineering official. Use arrow panels in the CBD for any work in a travel lane. Conform to the Ohio Manual Part 6, Section 6F.53, "Arrow Panels". For a stationary lane closure, locate the arrow panel on the shoulder at the beginning of the merging taper. Where the shoulder is narrow, locate the arrow panel in the closed lane. Use arrow panels in combination with appropriate signs, channelizing devices and other temporary traffic control devices. Locations which will require a flashing arrow panel will be as directed by the Engineer, as approved in the MOT notes and drawings, or as specified in the Detailed Specifications, General Notes, and/or Special Provisions for the Project.

Use properly weighted 36 inch (914 mm) drums or 36 inch (914 mm) grabber cones for standard channelizing devices for closing any lane to traffic. Use 36 inch drums or 36 inch grabber cones for tapers for lane closures. 28 inch (710 mm) cones may be used for daytime only, short duration closures. Do not exceed the distance equal to the posted speed limit for the spacing between all channelizing devices in the taper and transition area (example: if the posted speed is 25 MPH, make the spacing 25 feet). Do not exceed two times the posted speed limit as the maximum space between channelizing devices in the tangent area. Use channelizing devices that are orange in color with two or three retroreflective bands. Use only retroreflective material on channelizing devices that has a smooth sealed surface that will display approximately the same color day and night. Keep all retroreflective materials on devices in good condition, maintaining their retroreflective properties.

Restrict all vehicles, equipment, workers and their activities to one side of the pavement at all times, unless otherwise approved by the Engineer. Do not park or stop vehicles or equipment except within designated areas. Enter and leave work areas in a manner that will not be hazardous to, or interfere with, the normal flow of traffic. Do not park personal vehicles within the right-of-way, except in specific areas designated by the Engineer.

Maintain pedestrian protection and pedestrian access at all times in conformance with the Ohio Manual part 6D.01. "Pedestrian Consideration". Pedestrian safety is of utmost importance throughout the life of the Contract. Do not lead pedestrians into conflicts with work site vehicles, equipment or operations. Do not lead pedestrians into conflicts with vehicles moving through or around the work site. Provide pedestrians with a safe, convenient path that replicates as nearly as practical the most desired characteristics of the existing sidewalk(s) or a footpath(s). If the pedestrian pathway is to be closed, post signs and direct pedestrians to the safest crossing point. If the pathway is to be closed between safe crossing points, post signs in advance of the closed area at a safe crossing point or make arrangements for safe pedestrian passage. Provide approved type pedestrian barriers if required by Traffic Engineering or the Engineer. The safety of pedestrians is the responsibility of the Contractor.

Add after the last paragraph:

Unless additional requirements are cited in the Contract Documents, conduct construction operations so that all lanes are open and available for the movement of traffic between the hours of 7 A.M. and 9 A.M. and between 4 P.M. and 6 P.M., Monday through Friday. During all other working times, close only one lane at a time unless prior approval is obtained from the City Traffic Engineer or his or her Designee and the Engineer.

Failure to comply with the provisions of all Maintenance of Traffic items will result in liquidated damages being assessed against the Contractor at the rate listed in the Contract Documents for failure to complete on time. Liquidated damages will be assessed for each violation, each day.

Maintain work zone and other maintenance of traffic control as required by the Engineer in order to perform any materials testing or other related work at no additional cost to the City. Do not remove or modify the work zone pattern(s) until the Engineer has given his or her consent to do so.

614.09 Law Enforcement Officer. Add:

The use of a police officer(s) with a marked police vehicle is encouraged and may be required by Traffic Engineering or the Engineer when work is done within a signalized intersection. The hiring of a police officer is for traffic control assistance with traffic and pedestrian control, for the safety of the traveling public, pedestrians and for the safety of the workers. Make arrangements and pay for the services of an off-duty police officer and cruiser, as needed. The Cincinnati Police Department (564-1880) requires advance notice for these services. Discuss the duties of the police officer before the work is started.

Obtain approval from Traffic Engineering in advance of the closing of any road for the purpose of the proposed work. Provide advance notification in accordance with the Plans and Section 107.22.

614.10 Work Zone Traffic Signals. Add:

Refer to Section 1314 of this supplement for the requirements of Maintenance of Existing Traffic Signals and Street Lighting Circuits.

614.11 Work Zone Pavement Markings. Add:

Perform all permanent pavement markings under a separate pay item (See Item 640 – Pavement Marking and related sections). This does not relieve the Contractor from the responsibility to maintain visible markings after each workday.

Following both the grinding operation and the placement of the intermediate course of pavement, install Class I (full pattern) work zone pavement markings per the Pavement Marking Plans no later than the end of the work day and maintain them until the intermediate course or the surface course (whichever is applicable) of pavement is complete. Machine apply paint and glass beads. Do not spray paint markings using aerosol cans.

If areas of the roadway are opened to traffic after grinding and/or leveling operations, place temporary reflectorized foil tape following the Pavement Marking Plans immediately after both the grinding and the paving operations and maintain it until the full striping pattern is installed at or before the end of the work day. Place the foil tape as follows:

Centerline	1 foot yellow dash every 20 feet
------------	----------------------------------

Lane Line	1 foot white dash every 20 feet
Stop Line	1 foot white dash every 5 feet
Crosswalk Line	1 foot white dash every 5 feet

Following the placement of the surface course of pavement, install Class I (full pattern) work zone pavement markings per the Pavement Marking Plans no later than the end of the work day and maintain them until the permanent pavement markings are complete. Machine apply paint and glass beads. Do not spray paint markings using aerosol cans. Place temporary **removable** reflectorized tape (per the Pavement Marking Plans) immediately after paving utilizing the spacing listed above and maintain it until the work zone pavement markings or the permanent markings are complete. Use "Scotch Lane" 5710 Series Detour Grade tape manufactured by the 3M Company or an approved equal. **Do not use foil tape on the final or surface course.** Complete Work Zone or permanent pavement markings at or before the end of the work day the final or surface course is placed.

Install markings with the same professional alignment and general positive guidance that is utilized with the permanent pavement markings. The installation and maintenance of the work zone and other temporary markings are considered subsidiary obligations under the maintenance of traffic work items and separate payment for performing this work will not be made unless the bidding documents state otherwise. Contact the Engineer once work zone pavement markings are placed to schedule approval by Traffic Engineering staff.

Add:

Item 627 Driveways

627.01 Description. This work consists of the construction of Portland cement concrete driveways, Portland cement concrete base and asphaltic concrete surface driveways, and full-depth hot-mix asphalt driveways, including all the labor, materials, and equipment required to construct the driveways complete including excavation, preparation of the subgrade, construction of the base if applicable, construction of expansion joints, curing of concrete and placing asphaltic concrete surface. Construct concrete driveways seven inches (178 mm) thick. Sidewalks that cross the driveway shall be seven inches thick. Construct concrete base and asphaltic concrete surface driveways with a seven inch (178 mm) base and a two inch (51 mm) surface course.

627.02 Materials. Furnish materials conforming to:

Aggregate Base.....	304.01 and 304.02
Asphalt Concrete – Type 1	448
Concrete – Class QC1	499 and 511
Expansion Joint Material	705.03

627.03 Driveways. Construct driveways in accordance with the applicable standard drawings and as follows. Construct to the length and width approved by the Engineer.

627.04 Excavation. Excavate to the required depth and to a width that allows installation, bracing and subsequent removal of forms. Fine grade and solidly compact the subgrade with a five ton roller. Compact the subgrade by heavy tamping where the use of a

roller is impractical. Excavate to allow for installation of base where required by the Plans or standard drawings.

627.05 Forms. Use forms made of either steel or sound two-inch plank, straight, true and clean. Set the forms true to line and grade, firmly staked down and well braced.

627.06 Placing and Finishing. Place concrete in accordance with the requirements of 451.06. Provide an even and uniform broom finish placed parallel to the curb in the apron portion and perpendicular to the curb in the sidewalk portion. Place preformed expansion joint filler 1/2 inch thick on both sides between the driveway and the curb. If the driveway is over 30 feet long, use one inch thick joint filler along the curb. Install expansion joint filler and depress 1/4 inch and seal as provided in 451.15. Place expansion joint filler in the sidewalk portion as shown on the City Standard Drawings. Concrete shall be seven inches thick between these expansion joints.

627.07 Curing. Cure concrete driveways in strict accordance with the provisions of 451.10.

627.08 Asphalt Surface Course. Construct the asphalt surface course, where applicable, in accordance with the requirements of 448. Do not place asphalt surface course until the concrete driveway has cured sufficiently to support paving operations without damage.

627.09 Asphalt Driveway. This work consists of repairing/replacing asphalt driveways and asphalt aprons. Sawcut a neat perpendicular joint across the driveway at the limit of removal. Remove the necessary existing asphalt pavement and compact the subgrade. Place and compact full-depth 448 Type 1 hot-mix asphalt. Match the new pavement thickness with the existing driveway section. Seal the joint with an asphalt binder material meeting the requirements of 702.01 of the ODOT CMS.

627.10 Method of Measurement. The City of Cincinnati will measure driveways by the square foot of finished surface complete in place.

627.11 Basis of Payment. Payment for driveways is full compensation for excavation, backfill, base course material where required, expansion joint material and incidentals required to complete the driveway.

The City will pay for accepted quantities at the Contract price as follows:

Item	Unit	Description
627	Square Foot (Square Meter)	Concrete Driveway
627	Square Foot (Square Meter)	Concrete Base and Asphaltic Concrete Surface Driveway
627	Square Foot (Square Meter)	Asphalt Driveway Repair

Add:

Item 628 Sawing Concrete

628.01 Description. This work consists of providing all necessary labor, materials and equipment to perform sawing of concrete work except when sawing is included under other items of the work. Using a diamond saw blade, saw to a minimum depth of 1-1/2 inch (40 mm). Make the saw cuts carefully and in a neat manner with an approved concrete saw. No Vermeer™ concrete cutter or similar type of equipment utilizing a wide rotary cutting wheel will be permitted for this work. Provide layout of proposed sawcutting and obtain approval from the Engineer prior to starting work. Repair concrete not to be removed but damaged by the sawing operation without cost to the City and to the Engineer’s satisfaction.

628.02 Method of Measurement. The City will measure the actual number of linear feet of concrete sawed to the required depth.

628.03 Basis of Payment. Payment for Sawing Concrete includes the costs of providing sawblades, traffic control, and subsequent clean-up of saw slurry and/or debris and disposal of same in a lawful manner. The City will pay for accepted quantities at the Contract prices as follows:

Item	Unit	Description
628	Foot (Meter)	Sawing Concrete

Add:

Item 629 Curbs Reset

629.01 Description. This work consists of resetting and trimming existing curbs to line and grade with the face vertical. This work also consists of excavating, backfilling and installing concrete base and restoring adjacent surfaces. Reset only curbs in good condition as designated by the Engineer.

629.02 Materials. Furnish materials conforming to:

Aggregate Base.....	304.01 and 304.02
Asphalt Concrete Surface Course	448
Concrete Base.....	451
Concrete – Class QC1	499 and 511
Expansion Joint Material	705.03

629.03 Excavation. Excavate the trench for the curb to a depth of 24 inches (610 mm) below top of curb grade and to a width of 12 inches (305 mm) back from the curb line unless otherwise indicated on the plans or directed by the Engineer. Fill any areas of over-excavation with compacted aggregate base meeting the requirements of 304.

629.04 Curb Preparation. Re-dress the ends of the old curbs to make a joint not exceeding 1/4 inch (6 mm) wide for a distance of 12 inches (305 mm) down from the top.

629.05 Concrete Base for Curb. Spread a layer of stiff concrete on the bottom of the trench after the trench has been thoroughly cleaned of all loose material. Adjust and tamp concrete to correct line and grade.

629.06 Resetting Curb. Set the curb true to line and grade with the face vertical after the subgrade of the street has been roughly finished. Place additional concrete in back of the curb to a depth of eight inches (200 mm) from the top of the curb and spade well and tamp. Where driveways are required, lower the curbs as directed. Trim off the projecting ends of the adjoining curbs as shown on Standard Drawing Acc. No. 21508.

629.07 Backfilling. After the concrete has cured, fill the remaining space behind the curb with fine earth tamped to solid compaction where sod space adjoins curb. Where walk or driveway adjoins curb, backfill with aggregate base meeting the requirements of 304.

629.08 Restoration. Restore the Portland cement concrete walks, driveways and concrete base disturbed in the resetting of the curbs, as directed. Where directed, place expansion joint material behind the curb and between sections of curb.

629.09 Method of Measurement. The City will measure the linear feet of curb reset, complete in place.

629.10 Basis of Payment. The additional costs associated with excavation, moving the curbs (if required), concrete for bedding, backfill, and restoration of sod space and roadway are incidental to the completion of this item. Disturbed concrete walks and driveways shall be removed and restored to the nearest joint. Concrete walk and driveway restoration will be paid at the unit bid price of Item 608 or 627.

The City will pay for the accepted quantities of curb reset at the Contract price per linear foot as follows:

Item	Unit	Description
629	Foot (meter)	Curbs Reset

Item 630 Traffic Signs and Sign Supports

630.03 Certified Drawings. Add after the first paragraph:

Submit to the Project Engineer seven sets of drawings, catalogue cuts, and specifications for all traffic control signs for review and approval by the City Traffic Engineer or his/her designee. Do not purchase or install any signs without written approval from the City Traffic Engineer or his/her designee.

630.04 Sign Fabrication.

Add in the last sentence of the fifth paragraph the word "green" after the word "reflective".

Add after the fifth paragraph:

Use the official highway alphabet and letter series as shown on drawings that will be provided for all sign legends. Match existing signs and samples that may be provided for all inks and colors for the reflective sheeting. The City will not accept signs with improper color schemes or non standard fonts. The Contractor is advised to make sample signs for review and approval by the City before producing large runs of signs.

Add after the second sentence in the sixth paragraph:

Cut blanks of the thickness, size and shape as specified in the drawings. Ensure that all corners are properly rounded and free from rough edges.

Add to the eighth paragraph under the list of signs to be fabricated using fluorescent yellow green reflective sheeting:

CITY #159, #169I & #169R BACKGROUND FOR WORD "SCHOOL"

630.07 Sign Erection.

Add:

C. Curb Control (Parking) Sign Erection.

Mount all curb control signs at a 45 degree angle from the curb except for City #34 (street cleaning) and City #133 (snow emergency) signs. Mount all other signs at a 90 degree angle from the curb (perpendicular). See City standard drawings ES-6-1 and ES-6-2 for sign mounting and post installation details.

D. Parking Meter/Post Erection. Parking meter heads shall be removed and installed by City forces only as directed by the Engineer. Do not remove any meter posts until City forces have removed the meter heads. See Plans or City standard drawing ES-6-2 for sign mounting and post specifications and installation requirements.

E. Street Name Sign Erection. . Provide a minimum of thirty (30) days notice to the Engineer prior to the final traffic sign installations to arrange for City forces to fabricate the final street name signs unless otherwise noted on the Plans.

F. Pole Mounted Sign Erection. Meet the requirements of Item 630 including the exceptions shown on City Standard Drawing ES-6-1 for the pole mounted sign support assembly. Include in the unit bid price the necessary labor, brackets, banding, hardware and equipment to mount each assembly.

630.14 Method of Measurement

Add:

The City will measure Sign, Flat Sheet, Installation Only by the number of each sign installed to post, pole or wire, and will include the pickup of the signs, mounting hardware and equipment needed to mount each sign as shown on the plans and/or per City Standard Drawing ES-6-1.

The City will measure Sign, Flat Sheet, Allowance by the value of the invoice(s) received from the City of Cincinnati Sign Shop. No markup will be paid for this item.

630.15 Basis of Payment.

Add:

The City will pay for accepted quantities at the contract prices as follows:

Item	Unit	Description
630	Each	Sign, Flat Sheet, Installation Only
630	Lump Sum	Sign, Flat Sheet, Allowance

Add:

Item 634 Project Sign

634.01 Description. This work consists of providing all labor, materials and equipment necessary to furnish, erect, maintain for the duration of the project, and subsequently remove a new, professionally painted, project sign. This work also includes any necessary restoration of surfaces after removal to return the area(s) disturbed to as good as or better condition than originally existed.

634.02 Materials.

Furnish materials conforming to:

Anchors (if required)	Stainless Steel Epoxy Type, UNO
Concrete, Class QC1 (if required).....	499
Sign Board.....	MDO Board – Size 4’ x 8’ UNO
Sign Posts.....	4” x 4” Treated, UNO
Stainless Steel Hardware (if required)	730.10

634.03 Construction. Manufacture sign in accordance with the graphic shown below, including colors, fonts, and graphics. Add the project name, general contractor’s name and completion date to the sign. Provide proposed sign layout diagram to Engineer for approval at least 10 working days prior to project start. Erect sign using sign posts set firmly into the soil and braced as necessary, unless noted otherwise in the bidding documents. Maintain sign until



project completion or as otherwise directed by the Engineer. Locate signs in accordance with the bidding documents or as directed by the Engineer.

Project Construction Signage

4' x 8' digital print with UV inks and UV overlaminate. Mounted to 1/2" MDO board or Alumatic type material.

Contact Laura Martin of Transportation and Engineering for artfile at (513) 352-5268 or laura.martin@cincinnati-oh.gov.

634.04 Method of Measurement. The City will measure Project Signs by the number of signs provided and satisfactorily installed, maintained for the duration of the project, and subsequently removed, including the posts and any hardware necessary to provide for a complete installation, and any work necessary to restore disturbed surfaces after sign removal.

634.05 Basis of Payment. The City will pay for the accepted quantity at the Contract price for:

Item	Unit	Description
634	Each	Project Sign

Add:

Item 635 Cutting and Trimming Old Granite Curbs

635.01 Description. This work consists of the cutting and trimming of old granite curbs which are spalled or otherwise damaged, so that they will be acceptable to be reset in the new improvement. When so ordered, cut and form new ends on damaged curbs. Square and dress ends to afford joints not exceeding 1/4 inch (6 mm) wide for a distance of 12 inches (305 mm) down from the top of the curb.

635.02 Method of Measurement. The number of newly dressed ends will be the actual number of cuts made regardless of whether a cut produces one or two new ends.

635.03 Basis of Payment. The City will pay for the accepted quantity at the Contract price for:

Item	Unit	Description
635	Each	Cutting and Trimming Old Granite Curbs

Add:

Item 636 Bicycle Rack

636.01 Description. This work consists of furnishing all labor, materials and equipment necessary to construct and erect the completed bicycle rack of the type specified. Include all anchors, foundations, connections, shimming, and finishes necessary to complete this work. See the standard drawings for additional information.

636.02 Materials. Furnish materials conforming to:

Concrete – Class QC1	499
Concrete pad	608
Foundations.....	630.05
Steel pipe	707.70
Powder Coating.....	708.04
Galvanizing	711.02
Steel Base Plates.....	ASTM A36, 730.09
Anchor bolts	ASTM A36
Stainless Steel Pipe.....	730.09
Stainless Steel Hardware.....	730.10

636.03 General. Make the line and grade of the bicycle rack true to that shown on the plans. Shim vertically flange mounted racks. Designate Rack Types as "Type A/B/C/D/E – Capacity-Mounting-Finish" where:

Type isA, B, C, D or E
Capacity is either:2 or 4
Mounting is either: Flange (F) or Embedded Post Foundation (X)

Finishes are: Galvanized (G), Stainless (S) TGIC Powder Coated (T) or Powder Coat over Galvanized (G+T)

636.04 Fabrication. Fabricate bicycle racks out of steel pipe, nominal diameter, Schedule 40. Bend the pipe in one piece as shown on the standard drawing. Do not weld the bicycle rack in sections. Fabricate the base plate and cross bar in accordance with the standard drawing and continuously welded to the steel pipe prior to finishing. Finish the entire unit as specified.

636.05 Finishes. Clean steel to near white steel and treat with iron phosphate pre-treatment when TGIC powder coat finish (T) is specified.

Hot-dip galvanized racks after fabrication in accordance with 711.02 when galvanized finish is specified.

Powder Coat over Galvanized (G+T) – Galvanize per 711.02, but do not quench (water, chromate, phosphating) or apply any other post treatments prior to powder coat finish (T).

Polish stainless steel racks to #4 Architectural or satin finish after fabrication when stainless finish is specified.

636.06 Construction. Locate foundations for bicycle racks and stake at the proper location in accordance with the plans. The City will provide the staking where no locations or dimensions are given on the plans.

Prior to excavation, check for underground obstructions. After stakeout, notify the Engineer at least three days before the scheduled work so that the rack locations may be field checked by the Engineer for approval. The Engineer may change the bicycle rack location due to underground obstructions or lateral clearance requirements. After approval, take responsibility for the correct location and orientation for all rack foundations.

Perform excavation for foundations by earth auger; however, in areas of underground utilities, excavation must be by hand labor.

Use internally threaded epoxy system anchors, 1/2 inch (12 mm) (bolt size as manufactured by Epcon or approved equal). Conform installation to the Manufacturer's instructions. Anchors must be capable of developing an ultimate load capacity in tension of 2,000 pounds (900 kg). Install anchors in structural slabs to a depth not to exceed 75 percent of the thickness of the slab.

Core drill existing walks and structural slabs for flange mounting, using anchors and prepared in accordance with the Manufacturer's instructions. Shim flange mounted racks vertically, perpendicular to the rack.

636.07 Shipping and Storage. For bicycle racks, furnish only. Package all parts in protective plastic material and cardboard to protect finishes during shipping and storage.

Deliver packaged racks to:

Fred Anderton, Manager, Lunken Airport
City of Cincinnati, Division of Aviation
262 Wilmer Avenue, Cincinnati, Ohio 45226
513-352-6340

636.08 Method of Measurement. The quantity of bicycle racks will be for each type of bicycle rack installed. Do not measure anchors, excavation and concrete for foundations separately. Measure and pay for walk removal, concrete pads and concrete pavers installed for bicycle racks separately.

636.09 Basis of Payment. Payment will be made at the Contract unit price bid for each Furnish Bicycle Rack Type, which will be full compensation for all labor, equipment, tools, and incidentals necessary for each item furnished complete, in place, and accepted.

Item	Unit	Description
636	Each	Bicycle Rack – Type A, B, C, D or E
636	Each	Furnish Bicycle Rack – Type A, B, C, D or E

Add:

Item 637 Sheeting and Bracing Ordered Left in Place

637.01 Description. This item provides for payment only for sheeting and bracing left in place if shown on the Plans or in compliance with a written order from the Engineer. Cut off all sheeting and bracing left in place on a line six feet below the existing or proposed street surface, or three feet below the existing or proposed ground surface if not within the street right-of-way.

No payment will be made for waste material, for material cut off, for the excess size of unnecessarily large timbers. Sheeting and bracing left in place at the option of the Contractor, and sheeting and timbering left in tunnel will not be paid for under this item.

The right of the City to order sheeting or bracing left in place cannot be construed as an obligation upon the City to issue such orders, nor does the compliance with such orders or failure on the part of the City to exercise its right to issue such orders, release the Contractor from the responsibility for any damage caused by its operations, nor from its responsibility to protect the work and adjacent property.

637.02 Method of Measurement. The quantity measured is the number of board feet of sheeting and bracing ordered left in place or left in place as shown on the Plans. Sheeting will be considered to be two inches thick, unless heavier sheeting is ordered.

637.03 Basis of Payment. Payment for accepted quantities left in place in accordance with this specification will be made at the Contract price bid per 1,000-board foot measure (MBFM) which includes all the labor, materials and equipment required to furnish, install and cut off the sheeting and bracing for:

Item	Unit	Description
637	MBFM	Sheeting and Bracing Ordered Left in Place

Add:

Item 639 Architectural Poles and Accessories

639.01 Description. This item consists of providing all labor, materials and equipment necessary to fabricate, finish, transport, store, and erect architectural poles, hardware, accessories, attachments, meter arm holders and foundations complete and ready for service, including cleaning and preparing all exposed steel and aluminum surfaces (including the poles), and subsequently powder coating them. This item also includes the necessary excavation and backfill and disposal of excavated materials lawfully offsite and restoration of disturbed surfaces to a condition equal to or better than existing.

639.02 Materials. Furnish materials conforming to:

Bolts, Nuts, Washers (High Strength Unless Noted Otherwise)	ASTM A 325
Concrete – Class QC1	499
Fabricator Prequalification	513.03 – Level UF and/or AWS
Foundations.....	630.05
Galvanizing (Hot Dip Process).....	711.02
Powder Coating.....	708.04
Shop Drawings.....	501.04
Steel Pipe or Tube (Standard Weight and Seamless)	ASMT A 501
Structural Steel Shapes, Plates, Connection Material.....	ASTM A 36

639.03 Fabrication. Weld all connections throughout, unless bolting is specified or detailed. Grind all welded connections smooth. Bolt all field connections.

639.04 Finishing. Hot Dip Galvanize. Do not quench (water, chromate, phosphating) or apply any other post treatments since posts will be painted. Apply Federal Color specified on drawings per City Supplement Item 708.04 Powder Coating.

639.05 Shipping and Storage and Erection. Package all parts properly in protective plastic material and cardboard to protect finishes during shipping and storage. Store parts (if necessary) off of the ground and protected from the elements until such time as they can be installed. Erect and/or install in such a manner as to avoid damage to the finished surfaces. Repair any damage to the satisfaction of the Engineer.

Set pole in pipe sleeve using a medium grade coarse sand with differing sizes of particles that lock into each other to prevent installed poles from spinning. Meet ASTM C33 requirements.

639.06 Guaranty Period. Replace at no additional cost any part that fails in any manner by reason of defective material or workmanship for a period of 2 years unless a longer period is specified in the Bidding Documents.

639.07 Method of Measurement. The City will measure Architectural Poles, Architectural Pole Extensions, Poles Caps, Pole Boots, and Pole Foundations by type, each. Bike Rings, installation only, will be measured by each. Meter Arms and Holders, when specified on poles other than included in Item 639, will be measured by each.

639.08 Basis of Payment. The City will pay for the accepted quantities at the contract prices as follows:

Item	Unit	Description
639	Each	Architectural Pole – Type __
639	Each	Architectural Pole Extension – Type __
639	Each	Pole Cap – Type __
639	Each	Pole Boot – Type __
639	Each	Architectural Pole Foundation – Type __
639	Each	Bike Ring, Installation Only
639	Each	Meter Arm and Holder

Add:

Item 639.1 Caulking and Sealants

639.1.01 Description. This item consists of caulking all joints in concrete to match existing, caulking around all metal accessories in concrete or brick paving, and all other caulking shown or required by any drawings and not included with another section or as designated by the Engineer.

639.1.02 Materials. Provide only products that are recommended and approved by the Manufacturer for the specific use to which they are put and that comply with all requirements of the Contract Documents. For each generic product, use materials from only one Manufacturer. Provide only materials that are compatible with each other and with joint substrates. Provide colors of exposed sealers as selected by the Engineer. Provide materials conforming to:

Pavement Joint Sealant.....	713.01
Primer	713.02
Backer Rod	713.03

639.1.03 References.

- A. ASTM C 719 - 83 -- Standard Test Method for Adhesion and Cohesion of Elastomeric Joint Sealants under Cyclic Movement (Hockman Cycle); 1993.
- B. ASTM C 920 - 87 -- Standard Specification for Elastomeric Joint Sealants; 1987

- C. ASTM C 1193 - 91 -- Standard Guide for Use of Joint Sealants; 1991.
- D. FS A-A-272 -- Caulking Compounds; 190.
- E. FS SS-S-200E -- Sealants, Joint, Two-Compound, Jet-Blast-Resistant, Cold-Applied, for Portland Cement Concrete Pavement; 1984 (Amended 1988).

639.1.04 Inspection. Inspect all surfaces to receive caulking and sealant materials and report all defects. Starting work implies acceptance of surfaces as satisfactory. Verify that joints and spaces to be caulked or sealed are of proper width. Cure all concrete surfaces thoroughly. Do not apply caulking or sealants to surfaces contaminated with grease, oil, bituminous materials, form release agents, bond breakers, deleterious curing compounds, water repellants, and other special surface treatments

639.1.05 Submittals. Submit Product Data, Manufacturer's Installation/Application instructions and Cut Sheets for each joint sealer, including instructions for substrate cleaning and preparation, to the Engineer. Submit color selection samples consisting of cured samples of actual products showing the manufacturer's full range of colors available (products exposed to view only). Submit a Substrate Test Report for each Sealer as well as a Certified Test Report from an independent testing agency showing compliance with all specified requirements. Reports may be on tests conducted up to 24 months before submission, provided the products tested were aged specimens of the same formulation as to be used. Submit field inspection test reports. Certificates for each sealer are required. Provide Manufacturer's certificate stating the product complies with the specifications and is appropriate for the use it is being put to. Submit Installer's preconstruction inspection report, listing all conditions detrimental to performance of the joint sealer work. Submit a schedule showing maximum joint spacing allowable for each sealant compound. Submit this schedule for all joint sizes within 30 calendar days after award of the general Contract. This schedule will be reviewed along with shop drawings to verify conformity with job requirements and Manufacturer's current technical bulletins.

639.1.06 Preparation. Review all materials abutting sealant joints to determine whether form release materials etc., will have a detrimental effect on adhesion of this project. Thoroughly clean all joints, removing all foreign matter and protective coatings. Do not use any cleaning solvent which may leave a residue.

Clean out joints in accordance with the recommendations of the sealer manufacturers and as follows: Remove all material that could impair adhesion, including dust, dirt, coatings paint, oil, and grease before starting sealer installation; Exception: materials tested to show acceptable adhesion and compatibility; Dry out damp and wet substrates thoroughly; Clean M-Type (mortar) and O-Type (Other) substrates by suitable mechanical or chemical methods; Remove loose particles by vacuuming or blowing with oil-free compressed air; Remove laitance and form release agents; Clean A-Type (Aluminum) and G-Type (Glass) substrates by chemical or other methods which will not damage the substrate; Use methods which will not leave residues that will impair adhesion.

639.1.07 Substrate Test. Furnish samples of actual substrate materials tested by the sealer product manufacturer. The substrate sample will be tested to determine what preparation procedures (if any) are necessary to make sealers adhere properly under

environmental conditions that may occur during installation. Test to determine compatibility with substrates, backers, and secondary seals, if any. Use Manufacturer's standard test methods. Report the sealant Manufacturer's recommendations for substrate preparation and sealer installation and identify specific primers required. The requirement for testing will be waived if test reports based on previous testing of the product and substrates to be used are acceptable to the Architect/Engineer.

639.1.08 Field Installation Tests. Test the adhesion of all sealers to actual substrates before installation. Seal five foot (1.5 meter) lengths of joints and cure properly. Try to pull sealer out of the joint by hand, using a method recommended by the Manufacturer. Select test joints representative of joints to be sealed by the product to be tested. Perform this test for each type of sealer. Perform tests in the presence of the Architect/Engineer and the technical representative of the sealer's Manufacturer.

Peel Adhesion: Install samples in the field on various substrates with appropriate primers. Test samples at least ten days prior to commencing sealant work and inspect closely for adequacy of adhesion.

Primer Discoloration: Take special precautions to guard against primer being applied over any surface to remain exposed if discoloration is indicated and considered a factor.

Soundness of Substrates: Be responsible for providing sound, strong substrates of the dimensions shown on the drawings. Perform all subsequent work using the exact procedures established above.

Bear full responsibility for any decline in performance level of subsequent work, as compared to initial sample installations.

Mock-ups: Before beginning installation, install sealants in joints in actual construction as directed by the Architect, to show color, materials, and installation. Keep the Mock-ups intact as the standard for evaluating the completed work.

Pre-installation Meeting: Have the sealer installer, sealant manufacturer's representative, and other affected installer's meet to review sealer installation and protection procedures and the sequencing of related work.

639.1.09 Installation. Deliver materials in their original, un-opened containers or bundles with Manufacturer's label intact showing name of Manufacturer, product name, shelf life, date manufactured, and installation instructions.

Do not install sealers if any of the following conditions exist: air or substrate temperature exceeds the range recommended by the Manufacturer or is below 40°F (5°C); or if the substrate is wet, damp, or covered with snow, ice, or frost. Do not install sealers if joint dimensions are less than or greater than that recommended by the Manufacturer – notify the Engineer and get Manufacturer's recommendations for alternate products.

Examine joints for characteristics that may affect sealer performance, including configuration and dimensions. Do not begin sealer work until satisfactory conditions have been corrected.

Prime substrates as recommended by the sealer manufacturer. Use masking tape to keep primers and sealers off adjacent surfaces which would be damaged by contact or clean-up. Remove the tape as soon as practical. Prime all porous substrates for maximum adhesion. Check the recommended primer for possible yellowing, discoloration and dirt pick-up. Take adequate precautions to prevent the primer from being applied over the face of porous substrates by masking, etc., when dirt pick-up occurs after exposure. Apply the primer before installation of the backer rod.

Install fillers to provide proper joint depth or support for sealant backers.

Perform the initial work under the supervision of representative of the sealant Manufacturer. Maintain established job procedures, methods, and results for the duration of the project. Do not apply sealant below the temperature that is recommended by the Manufacturer in their published literature, and in no case under 40°F (5°C). When temperatures are between 40°F and 50°F (5° and 10°C), check material for prolonged tack and cure rate. Where installation below 50°F (10°C) is unavoidable, use Manufacturer's paving joint low temperature catalyst. Do not use catalysts when temperatures remain above 60°F (16°C).

Job mix multi component sealants with suitable power operated equipment. Prior to mixing any sealants for the project, the sealant Manufacturer's authorized representative must inspect and approve all equipment, and approve all mixing procedures. Furnish a letter to the Owner's representative verifying such approval. During the course of caulking and sealing operations, conduct periodic inspections to insure that all equipment is functioning properly and approved procedures are being adhered to.

Retain on an approved preprinted card a button or plug from each cartridge of sealant. Cross-reference the card to the location on the project where the sealant from the cartridge is applied. Show the date of mixing and application, material, manufacturer's batch number, and cartridge numbers on plug cards. Protect filled cards from damage until plugs are cured and then turned over to the Owner's Representative. Retain cards until the completion of all caulking and sealing work and use to isolate and identify potential areas of defective sealant, material.

For joints 1/2 inch wide, make depth equal to width but not less than 1/2 inch. For joints 1/2 inch to one inch wide, make depth 1/2 inch. For joints over one inch wide, follow the Manufacturer's published recommendations. Do not twist or stretch the preformed bead type or rope type back up materials during installation.

Use release material between the back-up material and sealant to confine adhesion to surfaces of materials being joined at joints subject to movement, where required by nature of the back-up material used, or where sealant contacts the back of the joint. Follow Manufacturer's published recommendations exactly. Furnish release material over support backing for all traffic bearing joints (not required over polyurethane backing).

Neatly tool joints slightly concave using the tooling agents recommended by the sealant Manufacturer. Repair any air pockets exposed during tooling. Tool the joint so as to compress the seal material and improve adhesion to surfaces joined.

639.1.10 Patching. Patch or replace defective or damaged sealants. Be responsible for damage to adjacent surfaces caused by caulking and sealing operations, and repair or replace same as directed by the Engineer.

639.1.11 Cleaning. Clean adjacent surfaces soiled by caulking and sealing operations. Remove wet material before it "sets". Follow Manufacturer's recommendations for cleaning procedures. Use non-staining or injuring cleaning agents on exposed surfaces. Use cleaning agents that are not potentially dangerous to metal surfaces to wash-off by rain.

639.1.12 Guarantee/Warranty. Provide a guarantee on an approved form, warranting all sealant work against defective material or workmanship for five years. Guarantee must further state that all sealants are guaranteed against: adhesive or cohesive failure where joint spacing is within the limits called for on Manufacturer's data sheets; any crazing developing on the surface of the material; for five years of outdoor exposure; any staining of adjacent surfaces by the sealant and/or primer (yellowing, etc.); any puncture, abrasion or tear failures in self leveling sealants installed on grade; excessive dirt pick up, chalking or color change on surface or cured sealers; any increase or decrease in Shore A durometer in excess of 25 percent of readings taken one month after cure. Supply an agreement to repair or replace all sealant defects, as listed above, which develop during the guarantee period at no cost to the City.

640 PAVEMENT MARKING

Item 641 Pavement Marking – General

641.01 Description. Add before the first paragraph:

For temporary work zone pavement markings, see Item 614.11 of the City Supplement.

641.02 Materials. Add after the last paragraph:

All permanent pavement marking materials shall comply with the latest ODOT specifications and proposal notes located on the ODOT website under "Design Resource Reference Center".

641.08 Marking Types.

Replace Sections E and F with the following:

E. Stop and Crosswalk Lines. Place stop lines as solid white stripes using the width specified. Place crosswalk lines as solid white stripes using the width specified.

F. Transverse/Diagonal Lines. Place transverse/diagonal lines as solid stripes of the width and color specified, and at an angle to the direction of travel.

641.10 Removal of Pavement Markings. Add:

Remove all existing pavement markings that conflict with the final pavement markings by methods approved by the Engineer . Cost for this work is incidental to the cost of the new pavement markings.

650 ROADSIDES

Item 657 Riprap for Tree Protection

657.02 Materials. Delete limestone.

657.03 Tree Wells in Fill. Replace the words "12 inches (310 mm)" with the words "4 inches (100 mm)".

Add after the last paragraph:

In addition to the requirements of this section, when a tree well is constructed:

1. Aerate the soil in accordance with 658.
2. Prune trees in accordance with ANSI 300 – 1995.
3. Fertilize trees according to National Arborist Association Standards (666.011).

Item 658 Tree Root Aeration

658.02 Materials. Add at the end of the first sentence "...and a neutral pH.

658.03 Preparation. Add after the end of the first sentence:

Do not use mechanized equipment, other than a hand or small riding lawn mower – do this work by hand. Do not disturb the topsoil and humus layer. Prune and fertilize trees as per 657.03.

658.041 Installation of Tile. Earth fills greater than 12 inches (305 mm), require the construction of a tile aeration/watering system. Construct tile lines at the base of the aggregate aeration course radiating from the well wall to the periphery of the tree branches in a pattern similar to the spokes in a wagon wheel. Install eight tile lines per tree in a fill that completely surrounds the tree. Tile will penetrate the well wall. At the periphery end of each tile line, angle the line on a right angle to the surface of the fill and terminate with a bell shaped tile with vented cover at grade. Hold the vertical column in place with a sufficient amount of cobble sized stone to hold it securely until the aggregate aeration course and earth fill are properly in place.

658.05 Aeration with Tree Wells. Add:

Earth filled greater than four inches (100 mm) requires tree root aeration. The four inch (100 mm) fill requires a two inch (50 mm) aggregate aeration course. At no time must fill or aggregate be placed within a tree well or touching the trunk of the tree. Aggregate must be one half depth of fill up to fills of 12 inches (305 mm).

658.07 Method of Measurement. Add to the end of the last sentence:

"...and the tile lines by the linear foot (m) including vertical line and bell tile with cover."

658.08 Basis of Payment. Add:

Item	Unit	Description
658	Foot (meter)	Tile Line Aeration System

Item 660 Sodding

660.04 Preparation of Areas to be Sodded.

Delete the first two sentences and replace with:

Before placing the sod, excavate the sod bed to such a depth so as to allow the placement of a layer of topsoil at least three inches (80 mm) in depth when compacted. Spread the topsoil at a grade which will assure that the surface of the sod after tamping will conform to the grade indicated on the plans, or as directed by the Engineer. Topsoil must meet the requirements of Item 653.

660.10 Method of Measurement. Add the words "sodding with topsoil," after the word "measure".

660.11 Basis of Payment. Add after the first sentence:

The City will pay for accepted quantities including the furnishing and placing of topsoil at Contract price for:

Item	Unit	Description
660	Square Yard (Square Meter)	Sodding with Topsoil

Item 661 Planting Trees, Shrubs, Perennials, and Vines

661.13 Mulch. Delete the first sentence of the second paragraph.

661.14 Pruning. Delete the first sentence.

Add:

Item 663 Ornamental Light Attachments in Trees

663.01 Description. This work consists of installing ornamental light strands to trees. The lights must be attached to the tree trunk and main limbs by screw eyes. Screw the eyes into the trunk at intervals of four feet (1.2 m). Attach electrical wire to the screw eyes with plastic bands or ties.

663.02 Materials. The materials consist of one inch (25 mm) long stainless steel screw eyes and plastic ties.

663.03 Basis of Payment.

Item	Unit	Description
663	Each	Ornamental Light Attachments

Add:

Item 664 Structural Soil Mix

664.01 Description. This work consists of installing structural soil mix in direct proximity to trees below sidewalks when specified by the Engineer.

664.02 Materials. Furnish materials conforming to:

Aggregate.....	703.01 - #57 Gradation
Topsoil	653.02

664.03 Composition. Create blend of materials consisting of #57 graded aggregate, topsoil and peat with the following characteristics:

- A. Mixture Ratio:** #57 Aggregate to filler, = 2.7:1.0 (by volume).
- B. Filler consists of:** 70 percent loamy topsoil (by Volume) and 30 percent peat (by volume).
- C. Voids in # 57 Aggregate:** 30.7 percent.
- D. Specific Gravity:** 1.89.
- E. Air Void/Porosity of Mixture at 100 percent compaction:** 27 percent.

664.04 Method of Measurement. The City will measure the volume of the space filled with the structural soil mix in its compacted state.

664.05 Basis of Payment.

Item	Unit	Description
664	Cubic Yard (Cubic Meter)	Structural Soil Mix

Add:

Item 665 Planting Salvaged Plants

665.01 Description. This item consists of excavating, transporting and re-installing salvaged plants.

665.02 Materials and Construction Methods. Prior to digging, mark each tree on the north side of the trunk with a small spot of paint. During transplanting, orient each tree to due north per the mark. Dig and handle each plant salvaged in full compliance with A.N.S.I. Z60.1 standards adhering to the earth ball size stated therein being considered the minimal acceptable size.

665.03 Method of Measurement and Basis of Payment. The City will measure and pay for this item in accordance with the provisions included in the Plans or elsewhere in the Contract Documents.

Item 666 Pruning Existing Trees

666.01 Description. Add after the first sentence:

All pruning and other tree work must conform to the following standards:

- A. National Arborist Association standards and ANSI 300 - 1995 for pruning of shade trees, guying of shade trees, fertilizing of shade and ornamental trees, lightening protection installation systems for shade trees and pesticide application procedures.
- B. A.N.S.I. Z133.1 - Safety Requirements for Tree Care and Removing Trees and Cutting Brush.

Copies of both of these standards are currently on file at the City's Park Board Operations Division Office.

Add:

666.015 Permits. Obtain a Public Tree Work Permit from the Park Board before any work is undertaken within 15 feet (5 meters) of any tree within the right-of-way under any Contract or Permit. Bring any conflict between the Contract requirements and the Park Board's requirements to the attention of the Engineer for resolution.

666.02 Wound Dressing. Delete this section and replace with:

Do not use tree wound dressing unless a designated brand is specified to reduce sucker sprouting stimulated by recent pruning on certain tree species.

666.03 Pruning. Add after the last paragraph:

Perform all pruning in conformance with the two standards specified in 666.01. In addition, the Engineer may order that specific branches be removed to minimize interference with traffic or pedestrians. Pruning also includes the removal of any plant material including vines within a three-foot (914 mm) radius of trunk.

666.04 Painting. Delete this section and replace with: Perform any painting operations in conformance with 666.02.

666.05 Removal of Foreign Materials from Trees. Delete the end of the last sentence after the word "tree" and replace with "...and prune in accordance with 666.01."

666.06 Removal of Rubbish. Add after the first sentence:

Complete this work within two hours of the time the tree is pruned.

Add:

Item 667 Large Trees Moved and Reset

667.01 Description. This item consists of digging, moving and resetting trees six inches (150 mm) or larger in diameter, including the digging of the necessary tree holes and drain pits, furnishing and placing the necessary topsoil, aggregate, peat, commercial fertilizer, mulch, water and other incidentals necessary to complete this item.

667.02 Material. Furnish materials conforming to:

Topsoil	653.02
Commercial Fertilizer	659.04
Backfill Mix	661.11
Mulch.....	661.13
Wrapping, Guying and Anchoring.....	661.15, 661.16

667.03 Preliminary Wrapping. Securely and properly wrap the tree with layers of burlap, and tie in the branches to prevent injury during digging, moving and planting.

667.04 Digging Trees. Dig each tree in such a manner that it may be lifted with the necessary roots enclosed in an earth ball having a minimum diameter 12 times the diameter of the tree. In all cases, ensure that the earth ball is of sufficient size to meet the requirements of ANSI Z 60.1.

Dig and/or move and/or reset only dormant trees unless otherwise directed by the Engineer.

667.05 Moving. Move trees with a root ball using only approved, standard tree-moving equipment.

667.06 Tree Holes. Dig tree holes for this item to a minimum depth of three feet (914 mm) with a minimum diameter of eight feet (2.4 m). In no case dig the tree hole less than 1-1/2 feet (460 mm) deeper than the depth of the root ball or the diameter less than the diameter of the root ball plus four times the diameter of the tree.

Slope the bottom of the tree hole toward the drain pit or as indicated on the Plans.

667.07 Drain Pits. When called for on the plans, provide drain pits in accordance with ODOT standard drawings or as directed by the Engineer.

667.08 Backfill Mix. Provide backfill mix for all trees reset. Do not use backfill mix in a frozen or muddy condition. Mix backfill on the project site unless otherwise directed by the Engineer.

667.09 Pipe Drains. Drain specified tree holes into a drain pit by pipe laid on the bottom of the tree holes, or as directed by the Engineer. Such drainage installation, including the necessary pipe, will be paid for in accordance with 603 of this Supplement.

667.10 Surplus Material. Dispose of any surplus materials in accordance with 105.16 and 105.17.

667.11 Pruning. Prune the ends of all broken and/or damaged roots 1/4 inch (6 mm) or larger with a clean cut removing no more than the injured portion. Prune the tops of all trees in compliance with the standards set forth in ANSI 300 - 1995 and ANSI Z 133.1 Safety Standards. Remove specified branches directly interfering with traffic or pedestrians, or as directed by the Engineer.

667.12 Wrapping. Wrap all trees in accordance with 661.15.

667.13 Bracing. Brace all trees in accordance with 661.16. Whenever the tripod guy type system is used in areas of pedestrian traffic, make the wires conspicuous to prevent accidents and liability to the City. Place yellow plastic tubing of uniform and sufficient length over the doubled wires to serve as a pedestrian warning or take other precautions as directed by the Engineer.

667.14 Mulching. Mulch in accordance with 661.13.

667.15 Period of Establishment. Place and care for all trees in accordance with 661.17.

667.16 Removal of Stakes and Wrapping. Remove in accordance with 661.18.

667.17 Method of Measurement. The City will measure the number, size and species of trees moved and reset, completed and accepted in place.

The City will measure aggregate for drain pits by the cubic yard (cubic meter) of drain pit constructed including all labor, materials and incidentals necessary to construct the pits.

667.18 Basis of Payment. The City will pay 80 percent of the bid price when the trees are delivered and reset at the project site and the remaining 20 percent if the trees are still living after the period of establishment. The City will not pay the remaining 20 percent if the trees have not survived the period of establishment or if the Contractor has not maintained the trees in accordance with the requirements of 661.17.

The City will pay for accepted quantities at the Contract prices as follows:

Item	Unit	Description
667	Each	Large Trees moved and Reset, (<i>Size</i>), (<i>Species</i>)

Add:

Item 669 Seeding and Other Matting Materials

669.01 Description. This work consists of furnishing, placing, and maintaining seeding and other matting materials on areas as shown on plans and as directed by the Engineer.

669.02 Materials. All materials must meet Manufacturer's specifications and be approved by the Engineer.

669.03 Construction. Apply all materials following the Manufacturer's specifications.

669.04 Maintenance. Maintain the matting areas as described in 659.18.

669.05 Method of Measurement. The yardage of the other matting materials must be the number of square yards (soil surface area) of the seeding (if required) and matting placed in accordance with the manufacturer's specifications, completed and accepted.

669.06 Basis of Payment. Payment for accepted quantities placed will be made at Contract price for:

Item	Unit	Description
669	Square Yard (Square Meter)	Seeding (if required) and other matting materials

Item 670 Erosion Protection

670.01 Description. Add the following:

An Erosion Control Plan is to be submitted and approved by the Engineer prior to beginning construction. No construction may begin until all appropriate erosion control measures are in place.

670.02 Materials. Add the following line:

Seeding and other matting materials.....669

670.03 Construction.

Add the following to the first sentence:

and, in addition, cover at least 75 percent of slope, ditch or swale with matting material.

670.06 Basis of Payment. Add the following to this sub-section:

New matting material, straw, coconut, fiberglass and paper strip matting, each requiring slightly different installation procedures, is now in place in Hamilton County. Some include their own grass seed and fertilizer incorporated in the material. Before placement, the Engineer must review and approve the use of any material other than as specified.

No specific item may be included for payment of erosion control measures. Erosion control measures are to be paid as part of other construction item.

700 MATERIAL DETAILS

700 Minimum Requirements for Sampling Materials

Replace applicable sections with:

Specification Number	Material	Material Only Inspection or Sampling Requirements	Post Inspection Instructions
305, 451, 452, 499	Concrete cylinders – pavement or base	Make 5 cylinders each day, each 100 CY (m ³) or fraction thereof.	
511, 499	Concrete for Structures	Make 5 cylinders each day, each class, each 100 CY (m ³) or fraction thereof, each span.	

703 Aggregate

703.01 General.

D. Method of Test. Replace: "Clay Lumps" test (S1017) with AASHTO T112.

703.05 Aggregate for Asphalt Concrete. (Intermediate and Surface Courses), Prime Coat (408), Chip Coat (422), and Microsurfacing (421).

B. Coarse Aggregate. Delete Section 1 and substitute:

1. Provide 100 percent crushed carbonate stone (CCS), 100 percent crushed air-cooled blast furnace slag (ACBFS), or 100 percent crushed washed gravel.

Add:

703.20 Bank Run Gravel. Provide sound durable materials containing not more than five percent clay or silt by weight and free from an excessive amount of deleterious material. Meet the following grading requirements:

100 percent passing a three-inch sieve (75 mm);
at least 90 percent passing a one-inch (25 mm) sieve;
not more than 25 percent passing a 1/4-inch (6mm) sieve;
and not more than 5 percent passing a No. 50 sieve.

704 Masonry Units

Add:

704.04 Clay or Concrete Paving Brick. Furnish manufactured paving bricks conforming to ASTM C902, Class SX, Type I Specification for Pedestrian and Light Traffic Paving Brick. Furnish solid pavers without core holes or other perforations meeting the following requirements:

Physical Dimensions 4" x 8" x 2-1/4" (101.6 x 202.2 x 57.15 mm)
Minimum Average Compressive Strength..... 8,000 psi (60 Mpa)
Average cold waterabsorption > 6% with no individual unit >7%
Freeze/Thaw Resistance > 50 cycles (ASTM C67)
Dimension Tolerances Meet PX standard
Dimension Tolerances around mean 1/16" (2 mm)

706 Concrete and Clay Pipe

706.02 Reinforced Concrete Circular Pipe. Modify ASTM C 76 accordingly:

2.1 Applicable Documents. Replace ASTM C 497 Testing Concrete Pipe or Tile with AASHTO T 33.

Modify Table 5 to include the following additional sizes:

Table 5 (Modification)

Internal Diameter of Pipe (inches)	Wall Thickness (inches)	Circular Reinforcement Inner Cage	Deformed Square Inches Outer Cage

6	1-3/4	0.07	—
8	1-3/4	0.07	—
10	1-3/4	0.07	—

11.4.1 Concrete Test Requirements.

Add:

Provide cores drilled from the wall of the pipe satisfying the minimum specified concrete strength requirements as outlined in the compression tests. Ensure that the diameter of the core has a capped height to diameter or L/D ratio between one and two. Secure and prepare the cores for testing as prescribed in the appropriate sections of AASHTO T 33. Ensure that the compressive strength of each core tested is equal to or greater than the design strength of the concrete. If a core does not meet the required strength, another core from the same pipe may be tested. Reject any pipe if this core does not meet the required strength. Provide additional tests on other pipe to determine the acceptability of the lot. When the cores cut from a section of pipe successfully meet the strength test requirement, plug and seal in a manner such that the pipe section will meet all of the test requirements of these specifications.

11.9 Absorption. Delete this section and substitute:

Ensure that the absorption of a sample from the wall of the pipe as determined in AASHTO T 33 does not exceed nine percent of the dry weight. When the initial absorption specimen from a pipe fails to conform to these requirements, perform another absorption test on another specimen from the same pipe and substitute the results of the retest for the original test results. Permit a retest on two additional pipe for each pipe that failed when the replacement specimen fail to conform to the specified requirements. Accept the pipe only when all retest specimens conform to the specified requirement. Obtain retest specimens from broken or unbroken pipe.

11.10 Retests of Pipe. Delete this section:

11.11 Test Equipment. Delete this section and substitute:

Furnish all facilities and personnel necessary to carry out the specified tests as described in AASHTO T 33.

16. Marking.

Add:

Mark on each section of pipe: (a) the pipe class, (b) type of wall to be designated as A, B, or C, mark wall thicknesses between standard ASTM wall thicknesses with the letters of both the thinner and thicker walls, i.e. A/B for wall thicknesses between A wall and B wall, (c) the date of manufacture, (d) the name or trade-mark of the manufacturer including plant location, (e) mark the center line of the crown and invert inside or outside the pipe with elliptical steel reinforcement and quadrant steel reinforcement at both ends, except where cast lift holes are centered over the crown. Mark the center line of the crown of the pipe without lift holes on the inside and outside of the pipe with TB, (f) mark the pipe with quadrant steel with the letter "Q"

(g) mark pipe with elliptical reinforcement with the letter E and (h) mark pipe with deformed reinforcement conforming to modified Tables 2 and 3 with the letters DF. Provide legible and indented marking on the pipe section or paint with waterproof paint.

706.04 Reinforced Concrete Elliptical Culvert, Storm Drain and Sewer Pipe.

Modify ASTM C 507 as follows:

2.1 Applicable Documents. Replace ASTM C 497 Testing of Concrete Pipe or Tile with AASHTO T 33.

11.5. Concrete Test Requirements. Add:

Provide cores drilled from the wall of the pipe satisfying the minimum specified concrete strength requirements as outlined in the compression tests. Ensure that the diameter of the core has a capped height to diameter or L/D ratio between one and two. Secure and prepare the cores for testing as prescribed in the appropriate sections of AASHTO T 33. Ensure that the compressive strength of each core tested is equal to or greater than the design strength of the concrete. If a core does not meet the required strength, test another core from the same pipe. Reject any pipe if this core does not meet the required strength. Provide additional tests on other pipe to determine the acceptability of the lot. When the cores cut from a section of pipe successfully meet the strength test requirement, plug and seal in a manner such that the pipe section will meet all of the test requirements of these specifications.

11.9 Absorption Test Requirements of Concrete. Delete this section and substitute:

Ensure that the absorption of a sample from the wall of the pipe as determined in AASHTO T 33 does not exceed nine percent of the dry weight. When the initial absorption specimen from a pipe fails to conform to these requirements, make another absorption test on another specimen from the same pipe and substitute the results of the retest for the original test results. Permit a retest on two additional pipe for each pipe that failed when the replacement specimen fail to conform to the specified requirements. Accept the pipe only when all retest specimens conform to the specified requirement. Obtain retest specimens from broken or unbroken pipe.

11.11 Test Equipment. Delete this section and substitute:

Furnish all facilities and personnel necessary to carry out the specified tests as described in AASHTO T 33.

706.05 Precast Reinforced Concrete Box Sections. Add:

Submit shop drawings in accordance with 501.04.

706.051 Precast Reinforced Concrete Three-Sided Flat Topped Culverts. In the fourth paragraph, delete the third sentence and replace with:

Submit shop drawings in accordance with 501.04.

706.052 Precast Reinforced Concrete Arch Sections. In the fourth paragraph, delete the third sentence and replace with:

Submit shop drawings in accordance with 501.04.

706.053 Precast Reinforced Concrete Round Sections. In the fourth paragraph, delete the third sentence and replace with:

Submit shop drawings in accordance with 501.04.

706.13 Precast Reinforced Concrete Manhole Riser Sections, Flat Slab Tops, Catch Basins and Inlet Tops, and Portable Barriers. Add:

Submit shop drawings for all precast structures in accordance with 501.04.

707 Steel, Aluminum and Plastic Pipe

707.15 Corrugated Steel Box Culverts. In the third paragraph, delete the second sentence and replace with:

Submit shop drawings for all structures in accordance with 501.04.

Modify:

707.25 Corrugated Aluminum Box Culverts. In the third paragraph, delete the second sentence and replace with:

Submit shop drawings for all structures in accordance with 501.04.

Add:

707.26 Cast Iron Pipe.

Provide cast iron pipe, fittings and joints for sewers conforming to AWWA Specifications C-102, C-106, C-108, C-110 and C-111.

Add:

707.27 Ductile Iron Pipe.

Provide ductile iron pipe, fittings and joints for sewers conforming to AWWA Specification C-151.

707.41 Smooth-Wall Polyvinyl Chloride Underdrain Pipe. Add:

Provide ASTM D-3212 joints flexible elastomeric seals, or solvent welded joints using ASTM D-2855 for PVC specified pipe.

Can only be used if cover is 35 feet (10.7 m) or less.

Type PSM Poly Vinyl Chloride (PVC) sewer pipe and fittings; ASTM D-3034 latest edition.

As a minimum, provide a Standard Dimension Ratio (SDR) of 35 for PVC.

707.52 ABS Sewer Pipe. Add:

Can only be used if cover is 35 feet (10.7 m) or less.

As a minimum, provide a Standard Dimension Ratio (SDR) of 35 for ABS.

708 Paint

708.02.D.1.f Urethane Finish Coat – Colors. Delete this section and replace with:

Unless otherwise noted on the plans, the finish coat color will be determined by the Architect/Engineer. Provide color selection charts, samples, etc., as required by the Architect/Engineer to assist with the selection.

Add:

708.03 Paint for Tree Grates. Provide metal primer – Rust-T-Bond Composite type 9804 as manufactured by Foy-Johnson Paint Company or approved equal. Provide exterior enamel top coat of Beige – 29804 or Char Brown – 39842 as manufactured by Foy-Johnson Paint Company as directed by the Engineer, or approved equal.

Add:

708.04 Polyester TGIC Powder Coat Finish System. Provide powder coated finish specified to have TGIC or Type "T" finish.

A. Cleaning and Pretreatment of Hot-Dipped Galvanized Items: Clean, rinse, pretreat, dry, and handle hot-dipped galvanized items as required per polyester powder coat primer coat and finish topcoat Manufacturer's published specifications.

B. Primer Coat: Provide electrostatic application of primer consisting of thermosetting epoxy powder coat:

1. Primer Design Standard: Corvel Zinc Gray 13-7004 (or approved equal).
2. Average Coating Thickness: 2 mils (allowable range = 1.8 mils to 2.2 mils)

Cure primer properly in a convection oven with proper time/temperature ratios for approximately 6 minutes at 250° F (120° C).

C. Polyester TGIC Powder Coat Finish/Top Coat: Provide electrostatic application of polyester TGIC (Triglycidyl Isocyanurate) Powder Coat Finish/Topcoat:

1. Color: Federal Color No. 27038 – Black – Semi-Gloss unless noted otherwise.
2. Average Coating Thickness: 3 mils (allowable range = 2 to 4 mils)
3. Sheen/Gloss Level: 30%

Cure finished topcoat properly in a convection oven with proper time/temperature ratios for approximately 20 minutes at 250° F (120° C).

D. Testing Parameters for Polyester TGIC Powder Coating:

1. Hardness: Minimum hardness of the cured film will withstand a 2H pencil across the coated surface at a 45 degree angle.
2. Humidity Resistance: Evaluated in accordance with ASTM D 2247 with humidity levels maintained between 95% and 100%.
3. Impact: Tested in accordance with ASTM D 2794 using 20 inch-pounds, minimum.
4. Salt Spray Resistance: Cured film shall exhibit the following performance as evaluated in accordance with ASTM B 117 for an exposure of 1,000 hours:

Property	Aluminum	Steel
Average Paint Thickness	3 mils (2 mils to 4 mils)	3 mils (2 mils to 4 mils)
Creep (12" average scribe)	0	0.20 inch (maximum)
Thru-Film Corrosion of Blistering	0	0.1% (maximum)

5. Crosshatch: In accordance with ASTM D 3359B, crosshatch at 95% or better at 1/16 inch spacing.
6. Conical Mandrel: In accordance with ASTM D 522, with a conical mandrel, no cracking at ¼" end.
7. Weather Resistance: Use a Type B Weatherometer in order to evaluate weather resistance in accordance with ASTM G 26. An exposure of 1,000 hours shall not reveal a change in gloss of more than 10%, or a Q.U.V. test chamber shall also be used in accordance with ASTM G 53 with no change in gloss more than 15% after an exposure of 100 hours.
8. Pinholes: Visual evaluation of the cured film shall not reveal the presence of pinholes on exposed surfaces.

9. Corrosion Testing: In accordance with ASTM B 117, the average scribe creep over a 12-inch scribe shall equal less than 1/8 inch at 1,000 hours. For marine test, the average scribe creep over a 12-inch scribe shall equal less than 1/8 inch in one year in 800 DOT exposure area.

E. Verification – Polyester TGIC Powder Coat Finish. Verify polyester powder coat paint application by submitting paint shop invoices. Submit paint shop documentation to verify conformance with Design Standard for Polyester Powder Coat Finish.

711 Structural Steel and Structure Incidentals

Add:

711.121 Cast Iron Tree Gratings. Furnish cast iron tree gratings according to ASTM A-48-83 Class 35 or better as manufactured by Neenah Foundry Company or approved equal.

712 Miscellaneous

Add:

712.14 Detectable Warning Devices.

A. Provide Surface Applied Detectable Warnings, Type O, as manufactured by:

Manufacturer	Product	Address/Phone	Color
Access Products Inc.	Access Tile – 24" x 48" Surface Applied (polymer composite)	241 Main Street, Suite 100 Buffalo, NY 14203 1-888-679-4022 or 1-347-278-7729 www.accesstile.com/products	Brick Red (RD) FED 22144 / RAL 3016
ADA Solutions, Inc.	24" x 48" Surface Applied Tactile / Detectable Warning Surface Tiles (glass, carbon and fiberglass composite)	P.O. Box 3 North Billerica, MA 01862 1-800-372-0519 www.adatale.com	Brick Red (Federal Color No. 20109)
Advantage Tactile Systems Inc.	24" x 48" Surface Applied Detectable / Tactile Warning Surfaces (stainless steel)	241 Main Street, Suite 100, Buffalo, NY 14203 1-800-679-4022 or 1-347-278-7729 www.advantagetactile.com	Brick Red (Federal Color No. 22144)
AlertTile	AlertTile – 24" x 48" Surface-Applied Detectable Warning System (glass-reinforced thermoset composite)	215 South Water Street Suite 103 Wilmington, NC 28401 1-877-232-6287 www.alerttile.com	Brick Red (Federal Color No. 22144)
Armorcast	24" x 48" Surface Mount Detectable Warning Panel (polymer concrete)	13230 Saticoy Street North Hollywood, CA 91605 1-818-982-3600	Brick Red

		www.armorcastprod.com	
Engineered Plastics Inc.	Armor-Tile – 24" x 48" Surface Applied Detectable / Tactile Warning Surface (vitrified polymer composite)	300 International Drive Suite 100 Williamsville, NY 14221 1-800-682-2525 www.armor-tile.com	Brick Red (Federal Color No. 22144)

Or approved equal.

B. Provide Composite Cast-in-Place Detectable Warnings, Type F, as manufactured by:

Manufacturer	Product	Address/Phone	Color
Access Products Inc.	Access Tile – 24" x 48" Cast-in-Place Replaceable (polymer composite)	241 Main Street, Suite 100 Buffalo, NY 14203 1-888-679-4022 or 1-347-278-7729 www.accesstile.com/products	Brick Red (RD) FED 22144 / RAL 3016
ADA Solutions, Inc.	24" x 48" Cast-in-Place Tactile / Detectable Warning Surface Tiles (glass, carbon and fiberglass composite)	P.O. Box 3 North Billerica, MA 01862 1-800-372-0519 www.adatile.com	Brick Red (Federal Color No. 20109)
ADA Solutions, Inc.	24" x 48" Cast-in-Place Replaceable Tactile / Detectable Warning Surface Tiles (glass, carbon and fiberglass composite)	P.O. Box 3 North Billerica, MA 01862 1-800-372-0519 www.adatile.com	Brick Red (Federal Color No. 20109)
AlertTile	AlertCast – 24" x 48" Cast-in-Place (Replaceable) Detectable Warning System (glass-reinforced thermoset composite)	215 South Water Street, Suite 103 Wilmington, NC 28401 1-877-232-6287 www.alerttile.com	Brick Red (Federal Color No. 22144)
Armorcast	24" x 48" Detectable Warning Panel Wet Set / Replaceable (polymer concrete)	13230 Saticoy Street North Hollywood, CA 91605 1-818-982-3600 www.armorcastprod.com	Brick Red
Engineered Plastics Inc.	Armor-Tile – Herculite Series – 24" x 48" Cast-in-Place Detectable / Tactile Warning Surface (vitrified polymer composite)	300 International Drive, Suite 100 Williamsville, NY 14221 1-800-682-2525 www.armor-tile.com	Brick Red (Federal Color No. 22144)
Engineered Plastics Inc.	Armor-Tile – 24" x 48" Cast-in-Place Detectable / Tactile Warning Surface (vitrified polymer composite)	300 International Drive, Suite 100 Williamsville, NY 14221 1-800-682-2525 www.armor-tile.com	Brick Red (Federal Color No. 22144)

Or approved equal.

C. Provide Metal Cast-in-Place Detectable Warnings, Type C, as manufactured by:

Manufacturer	Product	Address/Phone	Color
Advantage Tactile Systems Inc.	Advantage Stainless Steel – 24" x 48" Cast-in-Place Detectable / Tactile Warning Surfaces	241 Main Street, Suite 100, Buffalo, NY 14203 1-800-679-4022 or 1-347-278-7729 www.advantagetactile.com	Natural Finish
Advantage Tactile Systems Inc.	Advantage Cast Iron – 24" x 48" Cast-in-Place Detectable / Tactile Warning Surfaces	241 Main Street, Suite 100, Buffalo, NY 14203 1-800-679-4022 or 1-347-278-7729 www.advantagetactile.com	Natural Finish
East Jordan Iron Works	24" x 24" Series 7005 Cast Iron Detectable Warning Plates	301 Spring Street P.O. Box 439 East Jordan, MI 49727 1-800-874-4100 www.ejco.com	Natural Finish
Neenah Foundry	24" X 24" Series 4984 Cast Iron Detectable Warning Plates	2121 Brooks Avenue P.O. Box 729 Neenah, WI 54956 1-800-558-5075 www.nfco.com	Natural Finish

Or approved equal.

Add:

713 Sealant Materials

713.01 Paving Joint Sealants. Furnish a Paving Joint Sealant that is a multi-component polyurethane based sealant, gun grade in horizontal position, non-sag in vertical position, Sonolastic NP-2 joint sealant as made by Sonneborn Building Products Division of Degussa, THC-901 or Vulkem 227 from Tremco, DynaTrol II from Pecora Corporation, or an approved equal. Clearly indicate batch control numbers on all containers for base and accelerator components of multi-part sealants. Use identical control numbers for mixed components.

713.02 Paving Joints Primer Material. Furnish a primer recommended by the Manufacturer on all substrates, unless the Manufacturer's published literature states that the conditions of the performance guarantee can be met without the use of the primers.

713.03 Paving Joints Backer Material. Furnish a closed cell neoprene sponge rod conforming to ASTM C-509 for backup material for polyurethane sealants. Install rod under compression and at least 1/8 inch wider than the joint width. Furnish back-up material with depth as shown in the Manufacturer's literature. Furnish preformed, compressible, resilient, non-waxing, non-extruding closed cell polyethylene foam joint fillers, non-gassing and of size, shape, and density to control sealant depth.

Add:

730 Traffic Sign and Support Material

730.016 Square Posts. Add part C as follows:

- D. Posts are painted black for streetscape projects. The standard hot-dip galvanized posts will be used for all other applications.

1100 WATER MAIN WORK

The following provisions apply to the construction of all water mains and appurtenances, chambers, service branches and contingent work.

Item 1100 General Provisions

- 1100.01 General**
- 1100.02 Materials**
- 1100.03 Plans and Standard Drawings**
- 1100.04 Construction**

1100.01 General. Before beginning any work under the Contract, the Greater Cincinnati Water Works (GCWW) will furnish Plans to the Contractor showing approximate location of existing water mains, chambers, service branches, and other existing GCWW installations pertinent to the Contract. Examine the site with the GCWW Inspector and note the condition of all GCWW appurtenances.

The Contractor is responsible for the proper care and maintenance of all GCWW appurtenances that are found to be in good condition, and for those repaired or replaced during construction.

Note the condition of existing paving, not to be removed or replaced by a street improvement contract. When the work takes place in a political subdivision other than the City of Cincinnati, a representative of that political subdivision should be present. Upon completion of the project, the area in the vicinity of the project shall be in as good or better condition than existed prior to the beginning of work.

After the Contract has been awarded, and prior to starting the work, the GCWW Engineer will schedule a preconstruction meeting with the Contractor, representatives of the political subdivisions, and utility companies involved. The purpose of this preconstruction meeting is to discuss construction site safety, construction schedules, traffic control, and other aspects of the work that may concern the interested parties present.

Obtain all licenses and permits necessary to complete the work unless otherwise noted on the approved GCWW Plans.

Maintain traffic in a method approved by the authority having jurisdiction, or as specified in the Plans. Maintain proper and adequate access across all roadways, sidewalks, and driveways serving business concerns in the construction area. Install temporary sidewalks, wooden ramps, or bridges to allow the movement of pedestrian traffic at all times, taking special consideration regarding the safety of school children.

For all water main work, labor, and material conform to the GCWW Standard Drawings, specifications, and supplements which are the most current at the time of the opening of the proposals. Purchase copies of these items from the Greater Cincinnati Water Works (GCWW), 4747 Spring Grove Avenue.

1100.02 Materials. Furnish all material, unless otherwise specified in the item itself or on the approved GCWW Plans. Material to conform to the applicable City of Cincinnati Division of Purchasing Specification and/or GCWW Standard Drawings. All material must be inspected and approved by GCWW before installation. Pay all charges for shop and field inspection by GCWW personnel, where applicable.

On a concrete water main project, coordinate all details related to the approval process of the pipe laying schedule, pipe manufacturing, material delivery, and off-loading and storage.

Haul all items furnished by the GCWW from a GCWW Distribution Storage Yard to the work site. The Contractor will be paid for this hauling, except copper service branch material, under Item 1102.

Responsibly manage all materials issued and return all excess material to the GCWW for credit. Any material lost, stolen, damaged, or broken will be deducted from the final payment at the current price paid by the GCWW including an additional 33 percent for handling and storage.

1100.03 Plans and Standard Drawings. The underground utilities which are part of the Contract drawing have been shown in accordance with Section 153.64 of the Ohio Revised Code. In accordance with this Section, notify the Ohio Utilities Protection Service (OUPS) and/or the affected utilities two working days prior to commencing construction operations.

All utility information has been shown on the Plans from information provided by the owner of each utility. In cases where utility information is incorrect and it results in a change in the Plans, notify the owner of the utility to determine the necessary course of action. Submit any subsequent claims as a result of downtime or additional work to the owner of the conflicting utility. The Greater Cincinnati Water Works will not accept claims for any utility other than those as a result of incorrect water main and related appurtenance information.

The proposed locations of mains, valves, connections, fire hydrants, and water services, as shown on Contract drawings, are diagrammatical only. The final locations are subject to field conditions and will be determined by the GCWW Inspector as work proceeds.

Standard drawings concerning construction and installation details for water main work are on file in the Engineering Division of the Greater Cincinnati Water Works, 4747 Spring Grove Avenue, or the City Purchasing Division, and are available for reference or purchase.

1100.04 Construction. The amount and extent of new water main work will be shown on the Plans.

The Contractor's work hours are subject to the approval of the GCWW Director. The GCWW Director has the authority to direct the Contractor's forces to perform any work that, in his or her judgment, is necessary. The GCWW Director also has the authority to order the Contractor to increase or decrease the work forces at such locations that he may indicate.

All water main work shall be done in strict accordance with the specifications of the GCWW and under their direction, supervision, and inspection.

Adjust all chamber castings, valve boxes, fire hydrants, and water service boxes as indicated on the Plans. Those items to be salvaged or relocated will be so indicated on the Plans.

All valves in the Greater Cincinnati Water Works system will be operated by qualified GCWW personnel only.

The GCWW cannot, however, guarantee that all operated valves will provide a watertight shutdown. Every effort will be made to make a shut-down as quickly and effectively as possible. No allowance will be made to the Contractor for any delay in closing a valve or failure to provide a watertight shutdown.

Provide sufficient notice when a shutdown of valves will be required for any work activity.

Before the GCWW will schedule a shut down for tie-in purposes, the Contractor will be required to have all the necessary materials required to complete the tie-in on site to be approved by the GCWW Inspector. A shut down will not be scheduled if the Contractor does not have all the required approved materials on site.

Include all costs and charges for the restoration of street paving, sidewalks, or other areas opened or disturbed in the pursuance of water main work in accordance with the Plans, in the unit bid prices of the various items in the Proposal.

GCWW understands that differing site conditions sometimes result in extra work/change orders to the project. Change Orders, on GCWW Contracts, will be prepared and submitted in strict accordance with Section 109.05 C of the latest edition of the State of Ohio Department of Transportation Construction and Material Specifications and as modified in this City of Cincinnati Supplement. GCWW limits the mark up on wages and fringe benefits as described in 109.05 C. 2. "Labor" to 30 percent. It is expressly understood that, regardless of the nature of the claim or change in scope of work, the Contractor is not entitled to compensation for loss of anticipated profit or production.

Item 1101 Laying Pipe and Fittings

- 1101.01 Description**
- 1101.02 Responsibility for Material**
- 1101.021 Materials Furnished by Contractor**
- 1101.022 Materials Furnished by GCWW**
- 1101.03 Unloading and Storage of Materials**
- 1101.031 Staking of Proposed Water Main**
- 1101.04 Excavation and Preparation of Trench**
- 1101.05 Laying Pipe and Fittings, General**
- 1101.051 Railroad Crossing**
- 1101.052 Creek Crossing**
- 1101.053 Maintaining Water Service and Temporary Lines**
- 1101.054 Hydrostatic Test for Leakage and Water Main Flushing**
- 1101.055 Disinfection of Water Mains**
- 1101.06 Joining Pipe**
- 1101.061 Joining of Flange Pipe**
- 1101.062 Joining of Mechanical Joint Pipe**
- 1101.063 Joining of Push-on Joint Pipe (Compression Joint); Ductile Iron**
- 1101.064 Joining Steel Pipe**
- 1101.065 Joining Concrete Pipe**
- 1101.066 Joining High Density Polyethylene (HDPE) Pipe**
- 1101.07 Backfilling**
- 1101.071 Backfill Materials**
- 1101.072 Restoration**
- 1101.08 Method of Measurement**
- 1101.09 Basis of Payment**

1101.01 Description. This work covers the furnishing of all necessary labor, material, tools, and equipment required in laying various sizes of water mains and fittings. This work consists of unloading of material, proper storage of all pipe and fittings, excavating the trench, locating all utilities within the alignment of the proposed main, laying and joining the pipe, installing polyethylene wrap, cutting and removing existing pipe, making necessary connections and backfilling the trench, the repairing or replacing of all drains, sewers, utilities, and any other structures that may be disturbed or damaged by the Contractor's operations, and restoration of all disturbed surfaces. Include in this item the disposition of excavated material, testing and chlorinating the pipe in place, where applicable, installation of water mains and fire hydrant leads, as shown on the GCWW Plans, or as directed by the GCWW Director. Include in this item all costs associated with the maintenance of traffic in accordance with applicable permits and specifications.

When welded joints are required, retain the services of a testing agency, designated/approved by GCWW, to perform testing of all welds. Include the cost for this service in the unit bid price per lineal foot (meter) of laying pipe.

1101.02 Responsibility for Material.

1101.021 Materials Furnished by Contractor. Schedule the delivery of all material, including pipe and fittings. Coordinate the delivery with the GCWW. Be responsible for all material furnished. All material must conform to the requirements of the GCWW specifications. Furnish certification, analysis, and characteristics of all material. Material that has not been previously inspected and approved by GCWW will be inspected and approved at the job site. The GCWW Inspection Office requires 48 hours notice for this inspection and charges, when they apply, will be billed to the Contractor in accordance with Section 401.13 of the "Rules and Regulations of the GCWW". All materials that may come into contact with potable water must be accompanied by certification prior to approval and installation.

1101.022 Materials Furnished By GCWW. Be responsible for all material furnished by the GCWW.

Inspect all material furnished by GCWW and reject all defective material. Arrange for shipment of "piggy-back" trailers.

Responsibility for all material remains with the Contractor until final acceptance of the work by the City, and all surplus material furnished by the GCWW is returned to the GCWW Distribution Storage Yard and judged to be in proper condition.

1101.03 Unloading and Storage of Materials. Provide all labor, material, and equipment to unload pipe, valves, fittings, castings, or other appurtenances not unloaded by the pipe manufacturer. Use suitable slings, hooks, clamps, or skids, as approved by the GCWW Inspector, on all material. Under no circumstances will any pipe, fittings, valves, castings, or other appurtenances be unloaded by dropping from the trailer or truck bed.

Handle pipe and fittings so that the coating and lining are not subject to damage. If any part of the coating or lining is damaged, repair or replace such material in a manner satisfactory to the GCWW Inspector, at no cost to the GCWW.

Place all pipe and fittings on the job site on blocks and suitably chock to eliminate any possibility of rolling or shifting. Blocks and chocks shall have a minimum thickness of two inches (51 mm) and shall be high enough to assure that the pipe and fittings will not be touched by surface drainage.

Do not store any material within the public Right of Way, including sidewalks, unless previously approved by GCWW or as indicated on the approved Plans.

1101.031 Staking of Proposed Water Main.

On all Water Works Contracts, staking of the proposed water main is performed by GCWW or its representative.

On all private developments, standard water main staking consists of the following:

A. staking must be performed by a licensed surveyor.

All

B. Place a hub with lathe every 50 linear feet (15.2 m) unless in a radius or cul de sac. When staking a radius or cul de sac, place a stake every 25 linear feet (7.6 m), or less as directed by the GCWW Inspector.

C.

Sta

ke all "specials" (fittings, fire hydrants, valves, etc.) in addition to the dimensioning requirements under 2 above.

D. Identify hub with lathe as follows:

1. Station identification.
2. Ten foot (3 m) offset to centerline of proposed water main or fire hydrant.
3. The appropriate cut/fill to finished grade over the water main or fire hydrant.

E.

Ins

tall water main when rough grade on site is within one foot (305 mm) of the proposed final grade.

F.

For

proposed service branches, place a "blue top" stake, provided by GCWW, at the location of the proposed curb stop. Place a ten foot (3 m) offset stake directly back from the blue top stake. Identify the proposed cut or fill over the curb stop on the offset stake.

For street improvement projects, staking water mains is performed in the same manner as on private developments. Additionally, place a nail (or tack) in the existing pavement identifying proposed line and grade.

1101.04 Excavation and Preparation of Trench.

Description. The general proposed location of the pipelines and connections to the existing pipelines are shown on the Plans. If, during the course of work, unforeseen conditions arise, the location of the pipeline may be changed as directed by the GCWW Director to meet such conditions.

Proceed with caution in the excavation and preparation of the trench so that the exact location of underground structures, both known and unknown, may be determined.

Excavation. Excavation includes the loosening, handling, rehandling, removal, filling, and disposal of any and all materials, wet or dry, including gumbo, quicksand, hardpan, shale, rock, roadway pavement, granite blocks, cobblestones or brick pavers, street car rails, abandoned structures, and all unforeseen obstacles.

It is the nature of construction that unmarked utilities or utilities not shown on the Plans may be encountered within the excavation for the proposed work. Identify and remove any abandoned utilities encountered in the excavation. Unless otherwise noted on the Plans, no extra payment will be made to the Contractor for the identification and removal of the

abandoned utility. Include all costs for this work in the unit price bid for the appropriate Item 1101.

Remove rock or boulders encountered at the bottom of the trench and provide at least 4 inches (102 mm) embedment below the bottom of the pipe. Fill all voids left by the removal of rock and boulders with backfill gravel or embedment material compacted in 4-inch (102-mm) lifts.

Make all excavation by open cutting or trenching except where tunneling is required on the Plans or directed by the GCWW Inspector.

Maintain test holes or excavate trench a minimum of 50 feet (15.2 m) in advance of pipe laying, to assure proper clearance between the water pipe and any utility crossing, or underground structure. Brace and support all utilities and structures. Obstructions encountered during the installation of the main, due to the failure of having 50 feet (15.2 m) of trench excavated ahead of laying operations, may require removal and relaying of the pipe at the Contractor's expense.

All labor and material necessary to alter the water main utilities, or structures, due to failure of the Contractor to comply with these regulations is the responsibility of the Contractor.

Disturbed Pavement and Trench. The following dimensions of disturbed pavement will normally be allowed. Reference bid documents for more specific details.

- A. Do not disturb street pavement or sidewalk for a distance of more than 200 feet (61.0 m) ahead of the last laid pipe.
- B. Complete backfill within 50 feet (15.2 m) of the last laid pipe.
- C. Install temporary or permanent surface restoration within a distance of 200 feet (61.0 m) of the laid pipe, including those areas where main installations occur within a closed lane or closed street condition. Use roadway plates only as a temporary measure and for a period not to exceed 24 hours, unless otherwise authorized by GCWW.

Widths and Depths. Excavate to a sufficient width and depth to facilitate construction of the work to the lines, grades, and dimensions shown on the Plans, GCWW Standard Drawings, or as directed by the GCWW Inspector. In those cases where profile grades are not indicated on the Plans, the nominal widths and depths of trenches will be as follow:

Pipe Size	Cover Over Pipe	Clearance Under Pipe	Clearance Either Side of Pipe
12 inches (305 mm) and Under	3'-6" (1.067 m)	4 inches (102 mm) minimum	6 inches (153 mm) minimum
16 inches (406 mm) and Over	4'-0" (1.219 m)	4 inches (102 mm) minimum	6 inches (153 mm) minimum

Excavate chambers to a size that will facilitate the construction of the chambers to the dimensions specified on the GCWW Standard Drawings or as shown on the Plans.

Bell Holes.

Mechanical Joint and Compression Joint. Bell holes shall conform to the following dimensions:

Length = three feet (914 mm) – two feet (610 mm) in front of joint to one foot (305 mm) behind joint.

Width = six inches (152 mm) each side of pipe barrel.

Depth = six inches (152 mm) below pipe barrel.

Welded and Mechanical Coupling. Bell holes shall conform to the following dimensions:

Length = four feet (1.22 m) centered at joint.

Width = 18 inches (457 mm) each side of pipe barrel.

Depth = 18 inches (457 mm) below pipe barrel.

Blasting. Secure the approval of the proper authorities before blasting for excavations. Take the proper precautions to protect all people and property.

Additional Excavation. If any excavation is carried below the depth indicated on profile because of field changes ordered by the GCWW Inspector, or because of unsuitable soil conditions, the Contractor will be compensated under Item 1119.

Pipe Laying in Areas Where Grading Is Necessary. When a street is being improved or where new streets are being constructed, install water mains only when the proposed sub-grade has been properly prepared as stated in the specifications. Under no circumstances will any rolling or compacting by grading equipment be allowed after water main is laid.

Excavation in Unsuitable soil. Where the trench is found to be unsuitable or includes ashes, cinders, refuse, vegetable or other organic material, excavate and remove such material to a depth of an additional three inches (76 mm) to six inches (152 mm) below normal trench bottom and an additional four inches (102 mm) either side of the normal trench width.

Before installing the pipe, backfill the additional subgrade with backfill gravel in three-inch (76-mm) uncompacted layers. Thoroughly tamp the layers, as directed by GCWW Inspector, to provide continuous bearing and support for the pipe when pipe installation and final backfilling operations commence.

If, in the opinion of the GCWW Inspector, the bottom of the trench at subgrade is found to consist of material that is unstable to such a degree that it cannot be removed and replaced with granular backfill to support the pipe properly, then construct a foundation for the pipe,

consisting of timber, piling, or other materials. GCWW will compensate the Contractor for the timber and piling under Item 637 of this Supplement, for the concrete under Item 1110, and for the additional excavation and necessary backfill under Item 1119.

Sheeting and Bracing. Furnish, place, and maintain such sheeting and bracing as may be required to securely support the sides and ends of the excavations, to prevent injury to persons, and damage to property or to the structure being built. Install additional sheeting and bracing as deemed necessary by the GCWW Inspector. Compliance with such orders or failure on the part of the GCWW to issue such orders shall in no case release the Contractor from his liability for damages resulting from weak or insufficient sheeting, nor from his responsibility for protecting the work and adjacent property from damage. Immediately and completely fill voids appearing outside of the sheeting with suitable material in a satisfactory manner. Sheeting and bracing may be left in place at the option of the Contractor unless otherwise ordered by the GCWW Inspector. Remove sheeting and bracing only when sufficient backfill has been placed to provide ample support to the sides of the excavation. When sheeting is left in place, cut off a minimum of two feet (610 mm) below the proposed finished surface. Sheeting and bracing ordered left in place is paid for under Item 637 of this Supplement.

Shielding. Furnish, place, and maintain such shielding as may be required to securely support the sides and ends of the excavations, and to prevent injury to persons, and damage to property or to the structure being built. Immediately and completely fill voids appearing outside of the sheeting with suitable material in a satisfactory manner. Remove shielding only when sufficient backfill has been placed to provide ample support to the sides of the excavation.

Tunneling. Construct water mains in tunnels only when so indicated on the Plans or as directed by the GCWW Director.

When tunnels are constructed without the benefit of steel casing or tunnel liner plates, backfill the pipe area as specified in the GCWW Standard Drawings, and the balance of the area above the pipe with Class T under Item 1110. Ram the concrete portion of the backfill tightly against the undisturbed earth.

Construct tunnels using steel casing or tunnel liner plates as directed in Items 1107 and 1108.

Do not install water mains in any area where final grades have not been established and where grading has not been performed to provide nominal cover over water main when the street is built.

1101.05 Laying Pipe and Fittings, General. Provide and use proper tools and facilities for the safe and convenient performance of the work. Carefully lower all pipe, fittings, valves, and hydrants into the trench by means of derricks, ropes, or other suitable tools or equipment, in such a manner to prevent damage to the water main materials and protective coating and lining. Do not drop or dump water main material into the trench, under any circumstance.

Brush all pipe and fittings to remove all foreign matter and carefully examine for cracks and other defects while suspended above the trench, immediately before installation. Take

every precaution to prevent foreign material from entering the pipe while it is being placed into the trench.

Wrap all ductile iron pipe and fittings with polyethylene in accordance with GCWW Standard Drawing 105-5 and 105-5A. Wrap each pipe with polyethylene just prior to installation. Pre-bagging of multiple pipes is not permitted.

When pipe installation is not in progress, close the open ends with a watertight plug or other means approved by the GCWW Inspector.

If water is in the trench, leave the seal in place until the trench is pumped dry.

When foreign material and/or ground water enters the newly laid pipe, prior to filling and testing, poly-pig the entire pipeline to remove all possible contaminants at the Contractor's expense. Upon successful completion of the cleaning operation, GCWW will re-chlorinate the pipeline at the Contractor's expense.

Carefully wipe clean and dry the ends of the pipe before joining.

Pipe Embedment. Construct the trench with a flat bottom conforming to the proposed grade of the water main. Place the embedment material in the area of the pipe to a depth conforming to the dimensions as specified in Item 1101.04, and as shown on the applicable GCWW Standard Drawings.

Mechanically compact all embedment material and grade the surface to provide a uniform and continuous support beneath the pipe at all points between bell holes or pipe joints.

Where embedment material exceeds four inches (102 mm) below the bottom of the pipe barrel, place and mechanically compact additional embedment material in four-inch (102-mm) layers.

After each pipe has been graded, aligned, and placed in its final position, place and mechanically compact embedment material to a depth of twelve inches (305 mm) above the top of the pipe. Use special care in placing this portion of backfill so as to avoid damaging or moving the pipe.

Complete the trench backfill above the pipe embedment conforming to Item 1101.071 and to the applicable GCWW Standard Drawing. Strictly adhere to all restoration sections on GCWW Plans.

Blocking and Wedging. Place fire hydrants, valves, and fittings on hardwood blocks. Hold fire hydrants, valves, and fittings in position with hardwood wedges. Bed the blocks firmly in the bottom of the trench with uniform bearing and with the long dimension of the block perpendicular to the pipe barrel. Ensure that the blocks are level across the trench and place the proper number of blocks, one upon the other, to bring the fittings to the required grade.

Conform to the minimum dimensions indicated below for blocks and wedges:

Block Dimensions

Pipe Size	Thickness T	Width	Length
4 inches thru 10 inches (102 mm thru 254 mm)	2 inches (508 mm)	6 inches (152 mm)	12 inches (305 mm)
12 inches thru 20 inches (305 mm thru 508 mm)	2 inches (508 mm)	1/2 of Pipe I.D.	I.D. of Pipe
24 inches (610 mm) and larger	2 inches (508 mm)	12 inches (305 mm) minimum	I.D. of Pipe

Wedge Dimensions

Pipe size	Thickness (Taper)	Width	Length
4 inches thru 20 inches (102 mm thru 508 mm)	1-3/4" to 0" (45 mm to 0 mm)	4 inches (102 mm)	6 inches (152 mm)
24 inches (610 mm) and larger	1-3/4" to 0" (45 mm to 0 mm)	4 inches (102 mm)	6 inches (152 mm)

Deflection at Pipe Joint. The maximum permissible joint opening for a regular pipe joint is 1/2-inch (13-mm). Do not exceed Manufacturer's recommendations for joint deflections at special couplings. Do not deflect joints on either side of all valves.

Special Construction for Restraining Fittings. Under some construction situations, restrain a fitting by clamping, bolting, or tie-rods. Furnish the necessary material unless otherwise indicated on the Plans. Furnish all labor and equipment necessary to install this material.

Submit design and material specifications to the GCWW for approval before installation.

Coat all exposed surfaces of the restraining devices with Sherwin-Williams High solids Catalyzed Epoxy Paint (two-part mix NSF 61 approved). Apply all coating material to Manufacturer's recommendations.

Valve Installation. Install all valves with the valve-operating stem as truly plumb as practical.

In the installation of valves 16 inches (406 mm) in diameter and larger, pour the concrete floor of the valve chamber and allow to "set" before placing the valve. Precast floors are acceptable.

Test Holes. Dig test holes along the line of the proposed water main a minimum of 50 feet (15.2 m) ahead of the last laid pipe, including all connection points, to ascertain the location and elevation of utilities crossing the proposed water main. These excavations are considered necessary for water main installation. Include cost for all test holes in the Contract price bid for "Laying Pipe and Fittings". The GCWW will not accept a claim for different utility conditions encountered when test holes are not performed as required.

When the Plans specifically indicate that a test hole must be dug, or in other places where the GCWW Inspector deems necessary, GCWW will compensate the Contractor at the Contract price bid for Item 1120.

Cutting of Pipe. Cut all pipe and special castings necessary to install the water main as shown on the Plans or as directed by the GCWW Inspector. Include the cost for this work in the Contract price bid for "Laying Pipe and Fittings".

The GCWW Director must approve the method of cutting pipe. Do not use cutting torches or electrical devices to cut gray or ductile iron pipe.

Removing Existing Pipe. Cut and remove any existing water main normally in service to facilitate the connecting or joining of the new installation to existing water mains.

Carefully cut and remove the existing pipe at the point designated for the connection. Do not damage valves, specials, or pipe that is to be left in service. Assume responsibility for any such damage.

Remove any abandoned water mains encountered in the excavation for the proposed water main.

All pipe and fittings removed are the property of the Contractor, except for those that are salvaged under Item 1118.

Include the cost for removing water mains in the Contract price for "1101 - Laying Pipe and Fittings."

Air Releases. Install Air Releases where shown on the Plans and at all other high spots that may occur in laying of pipe. Payment for Air Release installation will be paid based on the Contract unit bid price for the appropriate Item 1116.

Install Air Releases in the connections provided by the pipe manufacturer in concrete and steel pipe. GCWW will compensate the Contractor for constructing the chamber under Item 1111.

Reconstruction of Subsurface Structures. While installing the water main it becomes necessary to alter or reconstruct a culvert, sewer manhole, valve chamber, catch basin connection, water main, water service, or sewer tap connections, in the same or new location, perform the work upon order from the GCWW Inspector. The Contractor will be paid for such work at the Contract price bid for the following applicable Items: 1101, 1126, 1110, 602 and 1123. GCWW will not compensate the Contractor for any alteration or reconstruction done for the convenience of the Contractor.

Obtain the written consent of the Owner before changing the position of any utility not specifically called for on the Plans.

Sealing Abandoned Utilities. Seal open ends of abandoned water mains, or water mains to be abandoned with this project, or any other utility, which are cut because of

trenching operations, with a brick or concrete bulkhead. The Contractor shall be compensated for this work under Items 602 and/or 1110.

1101.051 Railroad Crossing. Place the proposed water main in a suitable casing or tunnel liner, as specified on the Plans, when crossing under a railroad track. Item 1107 and Item 1108 specifies material and construction requirements for casing and tunnel liner.

Provide the owner of railroad property adequate notice before proceeding with any work involving the track, right-of-way, and appurtenances. The cost for any special traffic control, supporting devices, or other necessary precautions involving railroad personnel or property, shall be compensated as indicated in the Special Provisions of the Plans.

1101.052 Creek Crossing. Install proposed water mains, under creek beds, in accordance with the Plans or GCWW Standard Drawings. Concrete and reinforcing steel will be compensated for Under Item 1110 and 509. Restrain all pipe joints and fittings per GCWW Contract documents.

1101.053 Maintaining Water Service and Temporary Lines. Maintain adequate water supply to consumers and for firefighting purposes. Schedule operations to assure that water services and fire hydrants will not be out of service for more than the length of time which, in the opinion of the GCWW Director, is required for making necessary connections.

When water service may not be interrupted for the length of time required to make connections, the GCWW Director may order the Contractor to furnish, install, and maintain temporary pipelines. These temporary lines shall be of the size specified by the GCWW Director, which will adequately supply water for normal consumption and fire protection. Sterilize all such temporary pipelines to the satisfaction of the GCWW Inspector.

No additional payment will be made for temporary water mains or services unless specifically stated on the Plans or as a bid item in the Contract Proposal.

1101.054 Hydrostatic Test for Leakage and Water Main Flushing. After installation and backfilling operations have been completed, subject all newly laid pipe to hydrostatic pressure 50 psi (344.75 Kpa) greater than the nominal working pressures in the line being tested.

For all mains larger than 20 inches (508 mm) diameter, GCWW will provide the necessary labor and equipment to fill, chlorinate, and pressure test new mains. In the event pressure testing results in a failure by GCWW Standards, the Contractor will be responsible for all costs associated with the GCWW personnel conducting subsequent testing.

On all other mains, provide the necessary labor and equipment for the filling, chlorinating, pressure testing, and flushing operations. Submit all equipment for the approval of the GCWW Inspector.

Perform filling, chlorinating, pressure testing, and flushing operations Monday through Friday, unless otherwise directed by the Greater Cincinnati Water Works.

Isolate the section of pipe being tested, utilizing temporary plugs. Testing against a valve is prohibited.

Open all main line and fire hydrant valves prior to filling operations.

The GCWW Inspector will determine the location of the source water. The source water must contain a minimum system level chlorine residual of 0.2 ppm. Flush the source point, as necessary, until a system level residual is attained. Sample various locations in the proximity of the source point, under the supervision of the GCWW Inspector, to establish the system level chlorine residual. If a system level chlorine residual of at least 0.2-ppm is not attained, contact the Valve Department Supervisor before continuing with the fill.

Once the system level chlorine residual is attained, furnish and install the necessary assembly to begin the filling of the newly installed water main. The GCWW Inspector shall determine how the main shall be filled (ferrule to ferrule or fire hydrant to ferrule). Furnish equipment including, but not limited to, the following:

A. Nova Flex Model 6286 Fire Hose. NSF 61 Approved ¾ inch I.D.

B.

Fire Hydrant and Ferrule Adapters
Brass or copper fire hydrant and ferrule fittings/adapters.

Fir

C.

Line to include a check valve or other approved backflow device.

Fill

D.

Pocket Chlorine Test Colorimeter (HACH Co., Cat. # 5870000)
(Calibrated by certified GCWW personnel within last 3 months prior to use.)

Poc

E. High Test Chlorine Monitor (HACH Co., Model CN-2IP. Cat #24444-00)

Su

Submit all materials to the GCWW Inspector for inspection. Disinfect all material used for filling purposes.

Flush the fill hose until the system level chlorine level is attained. Slowly fill the section of pipe being tested with water and expel all air from the pipe. Open all hydrants and air cocks during filling operations. Close hydrants and air cocks as water reaches each point expelling the air. Once the filling operation is complete, the filled main shall be allowed to remain under working pressure for a period of 24 or 48 hours, as directed by the GCWW Inspector, to permit the concrete lining to absorb water and to allow the escape of entrapped air. At the end of the 24 or 48-hour period, obtain a high chlorine residual reading at each dead end sample point. Pump out all fire hydrants utilized to facilitate the filling process after each use.

All Contractor personnel associated with obtaining chlorine residual readings must obtain training from a certified GCWW Analyst.

Record and maintain all chlorine residual readings obtained. Provide a copy for the GCWW Inspector's daily log.

Begin the hydrostatic test within 48 hours of completion of the filling operation, prior to the high Cl₂ readings. Supply the water for the leakage test through the original source point. Pump the water to a pressure 50 psi (347.75 Kpa) over the working pressure. Maintain the test pressure for a two-hour test period with leakage not exceeding the maximum allowable. In the event that leakage within the maximum allowable cannot be maintained, locate and eliminate sources of water loss. Furnish all material, labor, and equipment necessary for this work. Include the cost in the Contract price bid for the appropriate Item 1101.

Repeat the leakage test after locating and eliminating the sources of water loss.

Perform the test unless otherwise indicated on the Plans.

Provide all labor and equipment, including pumps necessary to perform the test. The GCWW will provide the necessary gauges and meters.

Maximum Allowable Leakage Formulas

The maximum allowable leakage in cubic feet (cubic meters), while maintaining test pressure, is defined as:

Ductile Iron Pipe (mechanical joint & push-on joint):
(Based on AWWA Design Standard C600-05)

$$\text{Allowable Leakage } A = \frac{L \times D \times \sqrt{P}}{553,520} \text{ in cubic feet per 2 hours.}$$

Concrete Pipe:
(Based on AWWA Design Guideline M-9 Manual)

Allowable Leakage

$$A = \frac{L \times D}{47,392} \text{ in cubic feet per 2 hours}$$

Where: A = Allowable leakage in cubic feet per 2 hours.
 D = nominal inside diameter of pipe in inches
 P = test pressure in pounds per square inch (psi)
 L = length of pipe line in feet

Provide hydrostatic testing and all related testing equipment. Personnel involved with the testing operations must be certified by GCWW. All observed leaks must be repaired.

HDPE (High Density Polyethylene). Conform to Driscopipe Technical Note #35 – Method 1 – (2) Hour Test (copies of Technical Note are available at the GCWW Construction Inspection Office at 4747 Spring Grove Ave.) for pressure testing of HDPE. Prior to performance of the test, expel air from the pipeline to the satisfaction of the GCWW Inspector, using hydrants or air-cocks. If required, install taps at high points where air relief valves can be used to remove air. Include cost of taps in this Item. Plug taps after testing is complete.

Flushing. Begin flushing of the water main a minimum of 24 hours after the completion of hydrostatic testing. Furnish all equipment for the flushing operation. The necessary equipment includes that previously identified for filling of water mains. The GCWW Inspector will inspect all material. Disinfect all material used for flushing purposes.

Immediately prior to flushing, under the supervision of the GCWW Inspector, establish residual chlorine levels at each of the sample point locations. Attain a minimum of 10.0 ppm at each sample point to initiate flushing. If a chlorine residual below 10.0 ppm is identified, flush the sample point in question until a 10.0 ppm chlorine residual is achieved. Failure to achieve the minimum 10.0 ppm residual will result in GCWW re-chlorination of the entire main with all material, labor, equipment, and associated costs at the Contractor's expense.

Perform flushing from the original fill source through sample points. The source water must contain a minimum system level chlorine residual of 0.2 ppm. If necessary, flush the source point and the fill hose until the system level chlorine level is attained. Flush the main line section of the water main first down to 1 – 3 ppm. Upon completion of main line flushing, flush the remaining sample points (i.e. side streets and large branches) one at a time, under the direction of the GCWW Inspector, until 1 – 3 ppm is achieved at each location.

Complete flushing prior to noon for same day sample collections. The GCWW Valveroom Dispatcher shall be contacted by the GCWW Inspector at the start of the shift, on the requested sample collection day, to arrange for sample pick-up. First sample collection must also be scheduled to take place between Mondays and Thursdays.

1101.055 Disinfection of Water Mains. Properly disinfect all new water mains and all modifications to existing water mains prior to being placed into service as per AWWA Standard C-651 Disinfecting Water Mains. Specific requirements and modifications are as below.

Thoroughly clean the inside of all lengths of water mains and fittings with a chlorine/water solution prior to installation. Submit cleaning method to GCWW for approval.

Isolate the section of water main being disinfected by means of temporary plugs installed by the Contractor before beginning the disinfecting procedure.

Each dead end point of a new water main requires a temporary one-inch (25-mm) tap to obtain bacteria samples. For concrete water mains, utilize a two-inch (51-mm) tap provided on the bulkhead. Maintain access to the sampling tap. Furnish the necessary ferrules.

Install a one-inch (25-mm) tap ahead of the fire hydrant control valve, where the newly installed water main terminates at a fire hydrant.

Charge new water mains, smaller than 24 inches (610 mm), with chemicals supplied by the GCWW. Fill the new main with water and allow standing for a period of twenty-four hours. When non-liquid chlorine is used and cold weather dates established by GCWW are in effect, the filled main will stand a minimum of 48 hours. All mains 24 inches (610 mm) and larger are charged with liquid chemicals and filled with water by the GCWW, and allowed to stand for a minimum of 24 hours at all times of the year.

The amount of residual chlorine will be analyzed. If the main being disinfected fails to maintain the minimum allowable residual chlorine content, repeat the disinfection procedure.

Be responsible for all costs associated with subsequent testing performed by GCWW personnel in the event that the bacteria testing results in a failure by GCWW Standards.

In the event the residual chlorine is not sufficient after the second disinfection procedure is completed, remove sections of main, fire hydrants, or other appurtenances for proper flushing and possibly poly pigging. Furnish and pay for all material, labor, and equipment necessary for this work.

After the main has passed the pressure test and is flushed down to system chlorine levels, a bacteria sample will be taken by the GCWW Valve Room personnel at each dead end section of water main. A second and final sample will be taken 24-hours after the first sample. Each sample will require a minimum of 24-hours before results can be obtained, therefore the results of the bacteria samples will not be known for a minimum of 48-hours after the first sample is taken. If all samples show no signs of bacteria the water main will be allowed to be tied-in. GCWW will notify the Contractor when the water main is able to be tied-in.

Include all labor and material necessary to comply with this regulation in the unit bid price for the appropriate Item 1101.

1101.06 Joining Pipe.

General. Join all pipe and fittings in the manner specified by the GCWW. Complete any and all types of joints that are necessary. Joints at connections are specified from available information.

Coating Mechanical Couplings and Closure Assemblies. Coat all exposed steel pipe, couplings, flanges, or bolts, either buried or in chambers, with Sherwin-Williams High Solids Catalyzed Epoxy Paint (two-part mix NSF 61 approved). Apply all coating material in accordance with Manufacturer's recommendations.

1101.061 Joining of Flange Pipe. Manufacturing and installation must be in strict accordance with the most current editions of AWWA Specification C-111. Nuts and bolts shall be made of low-carbon steel as per Appendix C of AWWA C-111.

1101.062 Joining of Mechanical Joint Pipe.

Cleaning and Assembly. Thoroughly wire brush the last eight inches (203 mm) outside of spigot end, inside of bell, and the ductile iron gland to remove all oil, grit, excess coating, and other foreign matter from the joint. Paint this area with a non-toxic soap solution.

Slip the ductile iron gland onto the spigot end of the pipe with the lip extension of the gland toward the bell end. Paint the rubber gasket with the soap solution. Place the painted gasket onto the spigot end with the thick edge toward the gland.

Bolting of Joint. Push the entire section of the pipe forward to seat the spigot end in the bell. Press the gasket into place within the bell. Locate the gasket evenly around the entire joint. Move the ductile iron gland along the pipe into position for bolting. Insert all of the bolts and screw up the nuts tightly with the fingers. When a torque-limiting wrench is used, the torque for various sizes of bolt shall be as follows:

Bolting Diameter	Range of Torque
5/8 inch (15.9 mm)	40 to 60 foot-pounds (54.2 to 81.4 nm)
3/4 inch (19.1 mm)	60 to 90 foot-pounds (81.4 to 122 nm)
1 inch (25.4 mm)	70 to 100 foot-pounds (94.9 to 135.6 nm)
1-1/4 inch (31.8 mm)	90 to 120 foot-pounds (122.0 to 162.7 nm)

If a wrench other than a torque-limiting type is used, use the following wrenches:

Bolt Diameter	Length of WRENCH
5/8 inch (15.9 mm)	8 inches (203 mm)
3/4 inch (19.1 mm)	10 inches (254 mm)
1 inch (25.4 mm)	12 inches (305 mm)
1-1/4 inch (31.8 mm)	14 inches (356 mm)

Tighten alternately nuts spaced 180 degrees apart in order to produce an equal pressure on all parts of the gland. Disassemble, clean, and re-assemble all leaking joints. Nuts and bolts shall be made of high-strength low-alloy steel as per AWWA C-111, Section 4.4.5.

1101.063 Joining of Push-on Joint Pipe (Compression Joint); Ductile Iron.

Cleaning and Assembly. Thoroughly clean the inside of the bell and the outside of the spigot to remove all oil, grit, excess coatings, and other foreign matter. Flex the circular rubber gasket inward and insert into the gasket recess of the bell socket.

Apply a thin film of non-toxic vegetable-based gasket lubricant, meeting ANSI Standard 60/61 requirements, to the surface of the gasket and the spigot end of the pipe. Do not use mineral oil or petroleum based lubricants. Do not lay pipes in cold temperatures when gaskets and lubricants are not workable.

Enter the spigot end of the pipe into the socket with care to keep the joint from contacting the ground. Complete the joint by forcing the plain end of the pipe into the seat of the socket with a forked tool, jack-type tool, backhoe, or other approved method. Insert 12-

inch (305-mm) diameter and smaller pipe with the use of a spade or a bar and sufficient manpower to seat the joint. When completing a joint utilizing a 12-inch (305 mm) restrained joint gasket, use a backhoe where needed. Exercise care to not damage the gasket in this operation.

Mark pipe with a depth mark before assembly to assure that the spigot end is inserted to the full depth of the joint.

File or ground field-cut pipe lengths to obtain a chamfer, on outside of pipe, 1/8 inch (3.2 mm) from cut edge and at an angle of 30 degrees with the cut edge. Remove all rough or sharp edges from the cut edge to prevent possible damage to the rubber gasket.

1101.064 Joining Steel Pipe.

Manufacture/Installation. Manufacturing and installation must be in strict accordance with the most current editions of AWWA Specification C200 and AWWA M11 (Steel Pipe Installation Manual).

1101.065 Joining Concrete Pipe.

Cleaning and Preparing the Joint. Wire brush the spigot ring and bell ring of each pipe joint. Thoroughly clean both rings and the rubber gasket to remove all oil, grit, excess mortar, and other foreign material. Use an approved vegetable base lubricant on each gasket, spigot ring, and bell ring immediately before making the joint. Generously lubricate the gasket groove of the spigot ring. No foreign matter of any kind shall be allowed to touch any area after it has been lubricated.

Methods of Making Joints. Select one of the methods listed below for the installation of pipe, with the approval of GCWW Inspector.

Pull-jack inside method. Place the anchoring post for the jack at least three lengths from the pipe being installed. Firmly wedge the anchor posts to resist the pull necessary to install the pipe, without marring or chipping the lining of the pipe.

Pull-jack outside method. Place the anchoring sling for the jack at least three lengths from pipe being installed or brace an extra heavy trench jack securely against the trench in place of the sling.

Backhoe method. Push "home" the pipe with a backhoe. Use oak blocking between the pipe spigot/bell and the backhoe. Any obstructions encountered in the installation of the pipe, due to the failure of having 50 feet (15.25 m) of ditch open ahead of laying operations, may require the removal and relaying of the pipe at the Contractor's expense.

Checking the Joint. Place a 5/8 inch (15.9 mm) thick metal joint stopper at the spring line, between the spigot ring and "home" of the pipe bell, at the time the pipe is inserted. Use a feeler gauge to check the rubber gasket alignment in the gasket groove. When the rubber gasket is properly aligned, remove the stopper, and insert the pipe to the full joint depth.

Completing the Joint. Use a mortar mix composed of one part masonry cement 701.07, two parts of fine aggregate 703.03, and Cincinnati hydrant water or equal. Mix to a grout consistency to complete the joint outside. Use a stiff consistency for the joint inside.

Firmly secure the "diaper", furnished by the pipe fabricator, around the outside of the joint. Pour the grout mixture down inside the "diaper" from alternate sides of the opening, until the "diaper" is full. Trowel the top of the joint with stiff mortar.

Finish the inside of the joint with the stiff mortar to achieve a smooth effect. Remove any excess mortar.

Allow the completed joint to "cure" in accordance with the Manufacturer's recommended procedures before using any heavy equipment directly over the joint. This includes compaction of backfill. Failure to do so may require the exposure of each joint to verify its integrity at the Contractor's expense.

Coating Mechanical Couplings and Closure Assemblies. Coat all exposed steel pipe, couplings, flanges, or bolts, either buried or in chambers, with Sherwin-Williams High Solids Catalyzed Epoxy Paint (two part mix NSF 61 approved). Apply all coating material in accordance with Manufacturer's recommendations.

For closure assemblies, use a casing of concrete (one part Portland cement and two parts sand). Pour the concrete to obtain a minimum thickness of three inches (76 mm) around the outside of the exposed assemblies. Prior to pouring of concrete, wrap the closure assemblies completely in polyethylene.

1101.066 Joining High Density Polyethylene(HDPE) Pipe. Assemble HDPE in accordance with the related GCWW Standard Drawings and the HDPE Water Main Specifications.

1101.07 Backfilling. Backfill all pipe trenches, tunnel shafts, test holes, and other excavations required to install the proposed water main work as shown on the Plans or as directed by the GCWW Inspector.

Conform to the GCWW Standard Drawings.

1101.071 Backfill Materials.

Backfill Gravel. Conform to 703.11 except that no foundry sand will be allowed.

Pea Gravel. May be unwashed with 100 percent of the material passing 1/2-inch (12.7 mm) sieve, a minimum of 25 percent passing a No. 10 sieve, and a maximum of ten percent passing a No. 100 sieve. Do not include any slag, cinders, ashes, refuse, or other objectionable material.

Coarse Fill. Excavated material from the trench but must be reasonably free from rubbish, muck, shale, topsoil, or other unsuitable material. Maximum dimension of rock shall not exceed three inches (76 mm).

Granular Material. Conform to 703.11 except that no slag, slaker aggregate, or broken salvaged road metal will be allowed.

Methods for Backfilling.

Controlled Density Fill (CDF)/Controlled Low Strength Mortar (CLSM) (HAMCIN: CLSM-CDF) is an acceptable backfill material. Meet the requirements of Item 613 of this Supplement. Prior to placement of CDF/CLSM, place a compacted bedding of granular material 12 inches (305 mm) above all utilities within the excavation. In addition to Item 613 or HAMCIN: CLSM-CDF, whichever is applicable, the approved mixes must meet GCWW material specifications.

Method A Backfill. Conform to the GCWW Standard Drawings. After the embedment material has been placed, place the balance of the backfill material in six-inch (152 mm) compacted layers by a satisfactory mechanical means. Unless specifically noted on the Plans, all backfill shall conform to Method A.

Method B Backfill. Conform to the GCWW Standard Drawings. After the embedment material has been placed, place the balance of the backfill material in six-inch (152 mm) compacted layers by a satisfactory mechanical means. Method B will only be permitted when shown on Plans or specified in the Contract Proposal.

In lieu of mechanical compaction, the Contractor may request in writing to the GCWW to utilize jetting/flooding of the backfill material. If the permitting agency grants approval and it is determined by the GCWW that satisfactory drainage can be provided for, jet the backfill material with water to saturation. Following jetting, remove all free water from the trench by pumping or any other effective means. Perform all jetting in lifts in strict compliance with Item 603.09 of this Supplement.

Special Backfill. When other than standard backfilling is required, it will be so indicated on the Plans or noted in the Proposal.

1101.072 Restoration. Perform all temporary and permanent restoration as indicated on the Plans and/or in compliance with the requirements of the City of Cincinnati, Hamilton County, or appropriate political jurisdiction.

Roll all surface asphalt, temporary and /or permanent, into place. Do not tamp mechanically or use any other means.

Seeding performed within all drainage areas shall conform to Item 659, 712.11, and appropriate ODOT specifications. Use a reinforced woven fabric.

Replace all traffic control lines and devices disturbed by construction. Meet the requirements of the City of Cincinnati, Hamilton County, or appropriate political jurisdiction for traffic control.

Replace all removed sidewalk at the end of each work day with a temporary surface of asphalt or concrete, unless otherwise noted on the Plans.

1101.08 Method of Measurement. GCWW will measure the length of the accepted water main installed which includes the actual number of lineal feet (meters) of pipe, specials, an fittings measured along the center line of the water main in place.

1101.09 Basis of Payment. Payment is full compensation for all labor, material, equipment, and related testing, required to lay the pipe and fittings, and perform restoration as herein specified.

GCWW will pay for accepted quantities at the Contract prices as follows:

Item	Unit	Description
1101	Lineal Feet (meters)	Laying ___" (cm) (type of pipe) and Fittings
1101	Lineal Feet (meters)	Furnishing and Laying ___" (cm) (type of pipe) and Fittings

Item 1102 Hauling Water Works Materials

- 1102.01 Description**
- 1102.02 Measurement**
- 1102.03 Basis of Payment**

1102.01 Description. The work covers the loading and hauling all material furnished by the Greater Cincinnati Water Works, from a GCWW Distribution Storage Yard, or other designated location, to the project site.

Load and store all material according to 1101.03.

1102.02 Measurement. GCWW will measure the total tonnage of all material hauled from a GCWW Distribution Storage Yard to the job site, and the total tonnage of all surplus material furnished by the GCWW returned to the GCWW Distribution Storage Yard.

The pipe manufacturer will deliver concrete pipe and fittings to the job site. Return excess concrete pipe and fittings to the GCWW Distribution Storage yard.

The hauling of material furnished by the GCWW for service branches, will be paid for under Item 1126.

Any additional movement of any pipe or material within the confines of the project is the responsibility of the Contractor. Include the cost of any such work in the price bid per lineal foot (meter) of laying pipe, Item 1101.

1102.03 Basis of Payment. GCWW will pay for accepted quantities at the Contract prices as follows:

Item	Unit	Description
1102	Tons (tonnes)	Hauling Water Works Material

Item 1103 Lowering Existing Water Mains

1103.01	Description
1103.02	Materials
1103.031	General
1103.032	Lead Joints
1103.033	Mechanical Joints
1103.034	Sulfur-Based Jointing Compound
1103.035	Mechanical Coupling
1103.04	Measurement
1103.05	Basis of Payment

1103.01 Description. The work covers the lowering of existing water main, fittings, and fire hydrants where shown on the GCWW Plans or as directed by the GCWW Inspector. Perform this operation while the water main is under pressure, and maintain water supply for domestic consumption and fire fighting purposes. Restore the disturbed area as required.

1103.02 Materials. Furnish all material required to lower existing water main, and to make joints watertight.

1103.031 General. Dig test holes at those locations indicated by the GCWW Inspector to determine the elevation of the existing water main. If the elevation of the existing water main warrants lowering, excavate the trench under the water main and lower the water main so that the top of the pipe will be 3-1/2 feet (1.07 m) below the surface of proposed finished grade.

Where water main is encased in polyethylene, remove the existing encasement. Install new polyethylene encasement in accordance with GCWW Standard Drawing 105-5.

If the elevation of the existing water main indicates lowering is not necessary, the Contractor will be compensated for the test holes under Item 1120.

In the event other underground structures interfere with the lowering process, cut or disconnect the water main, and re-lay below such structures.

Perform lowering gradually and in a careful manner. The Contractor will be held responsible for any cracking, breakage, or damage to the pipe and appurtenances.

After the pipe has been lowered, the GCWW Inspector will check all joints, and determine if they are watertight. Backfill and restore the trench area. Comply with the

requirements of the City of Cincinnati, Hamilton County, or appropriate political subdivision for all temporary and permanent restoration.

1103.032 Lead Joints. Re-caulk or repour all poured lead joints as necessary to make the joint watertight.

1103.033 Mechanical Joints. Remove and replace all mechanical joint bolts and nuts. When necessary to provide water tightness, cut the pipe install a new rubber gasket.

1103.034 Sulfur- Based Jointing Compound. If a joint leak occurs in sulfur based jointing compound joints, remove and replace with new pipe and mechanical sleeves.

1103.035 Mechanical Coupling. Remove and replace all bolt and nuts.

1103.04 Measurement. GCWW will measure the actual number of lineal feet (meters) of pipe and fittings measured along the centerline of the lowered water main in place, completed, and accepted.

The price per lineal foot (meter) of water main lowered will include the resetting of fire hydrants.

1103.05 Basis of Payment. Payment is full compensation for all labor, material, and equipment to lower the water main, fittings, fire hydrants, and perform restoration, as herein specified.

GCWW will pay for accepted quantities at the Contract prices as follows:

Item	Unit	Description
1103	Lineal Foot (meter)	Lowering Existing ____" (cm) Water Main

Item 1104 Installing Valves on Existing Water Mains

- 1104.01 Description**
- 1104.02 Materials**
- 1104.03 Construction**
- 1104.04 Measurement**
- 1104.05 Basis of Payment**

1104.01 Description. This item covers the installing of valves on existing water mains.

1104.02 Materials. GCWW must inspect all valves, pipe and fittings.

1104.03 Construction. Make any necessary excavation, cut and remove a piece of existing pipe, and install a valve, necessary pipe, and fittings conforming to Item 1101. Install polyethylene. Backfill all excavations as described in 1101.07 and restore all disturbed surfaces.

1104.04 Measurement. GCWW will measure the Installation of Valves on Existing Lines by the number of each size completed and accepted.

1104.05 Basis of Payment. Payment is full compensation for all labor, material and equipment required to install the valve on the existing water main as herein specified.

GCWW will pay for accepted quantities at the Contract prices as follows:

Item	Unit	Description
1104	Each	Installing ____" (cm) Valve on Existing Water Main
1104	Each	Furnishing & Installing ____" (cm) Valve on Existing Water Main

Item 1105 Plugging Existing Water Mains and Fittings

- 1105.01 Description**
- 1105.02 Construction**
- 1105.03 Measurement**
- 1105.04 Basis of Payment**

1105.01 Description. This work covers plugging existing water mains and specials at the point indicated on the Plans, or as otherwise required, placing concrete blocking, and backfilling and restoring all disturbed surfaces.

A. Plugging work not covered by this item:

1. Any plugs required for testing or sterilization purposes.
2. Any plugs made for the convenience of the Contractor.
3. Any permanent plugs placed in water mains or specials in the installation of new water mains.
4. Any temporary plugging necessary to provide water for consumers or fire protection, unless specifically indicated on the Plans as a pay item.

1105.02 Construction. Make the necessary excavation and carefully remove the old pipe, install the plug, and make the required joint.

Firmly secure the plug with a mechanical clamp and/or block with concrete Class QC1 as directed by the GCWW Inspector.

Backfill the excavation as described on the GCWW Standard Drawing and restore all disturbed surfaces. Seal open ends of water mains abandoned, because of the installation of plugs, with a brick or concrete bulkhead.

1105.03 Measurement. GCWW will measure Plugs in Existing Water Mains and Fittings by the number of each size completed and accepted.

1105.04 Basis of Payment. Payment is full compensation for all labor, material, and equipment necessary to complete the work as herein specified.

Concrete used for blocking will be paid for under Item 1110.

GCWW will pay for accepted quantities at the Contract prices as follows:

Item	Unit	Description
1105	Each	Furnishing and Installing ___" (cm) Plugs in Existing Water Mains and Fittings

Item 1106 Furnishing and Installing Foamglas Pipe Insulation

- 1106.01 Description**
- 1106.02 Measurement**
- 1106.03 Basis of Payment**

1106.01 Description. This item covers the furnishing of all labor and material necessary to install FoamGlas preformed pipe insulation wrapped with a double layer of polyvinyl tape on water mains.

Water Main Size	Insulation Thickness
4 inches to 8 inches (102 mm to 203 mm)	2-1/2 inches (63.5 mm)
10 inches to 16 inches (254 mm to 406 mm)	3-1/2 inches (89 mm)

1106.02 Measurement. GCWW will measure the actual number of linear feet (meters) of pipe insulation along the centerline of the pipe insulation in place, completed and accepted.

1106.03 Basis of Payment. Payment is full compensation for all labor, material, and equipment required for the installation of the 2-1/2 inch (63.5 mm) or 3-1/2 inch (89 mm) thick pipe insulation.

GCWW will pay for accepted quantities at the Contract prices as follows:

Item	Unit	Description
1106	Linear Foot (meter)	Furnishing and Installing ___" (cm) Foamglas Pipe Insulation

Item 1107 Furnishing and Installing Tunnel Liner

- 1107.01 Description**
- 1107.02 Materials**
- 1107.03 Construction**
- 1107.04 Measurement**
- 1107.05 Basis of Payment**

1107.01 Description. This work consists of furnishing and installing a tunnel liner of the size indicated, to permit the laying of water mains as shown on the GCWW Plans or as directed by the GCWW Inspector.

1107.02 Materials.

Tunnel Liner	-City of Cincinnati Division of Purchasing Spec. 5-3 or latest revision thereof.
Cement for grout	701.04
Sand for grout	703.03
Concrete, Class QC1	1110.021
Pea Gravel.....	1101.071
Brick.....	704.02

1107.03 Construction. Make any excavation, mining and boring necessary to install the tunnel liner. Provide a shaft of adequate size to facilitate the work at the beginning of the tunnel installation. Install sheeting and timbers as required to fully protect the structure and the workers, and to prevent settlement of pavement curbs, walks, buildings, or other structures.

Light and ventilate the tunnel to allow proper construction and inspection. The Engineer will provide control points inside the tunnel as work progresses. Use the control points and install the liner to the line and grade as shown on the Plans or as directed by the GCWW Inspector. Protect and safeguard such control points from damage or movement.

A maximum deviation of six inches (152 mm) from true line and grade will be allowed. Correct any deviation greater than six inches (152 mm) by re-mining, so that the pipe may be laid to true line and grade in the tunnel.

Install one panel, containing a grout hole, in each ring or course. Space the panels 90 degrees apart, circumferentially, in each succeeding ring or course. Perform grouting to back up the liner plates and fill all voids as directed by the GCWW Inspector.

Install a concrete base or floor as wide as the O.D. of the pipe for the full length of the tunnel to provide a firm footing for supporting the water main. Submit the method for loading the pipe into the tunnel to GCWW for approval.

After the water main is laid in the tunnel, backfill the area between the outside of the water main and the tunnel liner plates with pea gravel.

Close both ends of the completed tunnel with four-inch (102 mm) brick bulkheads.

When directed by the GCWW Inspector, install a four-inch (102 mm) drain in the bulkhead.

Perform all restoration as specified.

1107.04 Measurement. GCWW will measure the actual number of linear feet (meters) of installed tunnel liner as measured along the center line of the water main.

1107.05 Basis of Payment. Payment is full compensation for labor, material, and equipment necessary to install the tunnel liner as herein specified.

GCWW will make compensation for the installation of the water main within the tunnel liner under the appropriate Item 1101.

When the GCWW Inspector orders sheeting and bracing to remain in tunnel shafts or pipe trenches, compensation will be made under Item 637 of this Supplement.

GCWW will pay for accepted quantities at the Contract prices as follows:

Item	Unit	Description
1107	Lineal Foot (meter)	Furnishing and Installing ___" (cm) Tunnel Liner

Item 1108 Furnishing and Installing Steel Casing

- 1108.01 Description**
- 1108.02 Materials**
- 1108.03 Construction**
- 1108.04 Measurement**
- 1108.05 Basis of Payment**

1108.01 Description. This work covers furnishing and installing a casing of the diameter and wall thickness indicated and furnishing and installing approved casing insulators,

to permit the installation of a water main as shown on the GCWW Plans or as directed by the GCWW Inspector.

1108.02 Materials.

Steel	ASTM A-139 Grade B
Type of Jointing	Welded
Brick	704.02
Concrete, Class QC1	1110.021
Coating	Bituminous or Approved Equal

1108.03 Construction. Make all necessary excavations to complete the boring or jacking operation to install the steel casing. Submit the method of boring or jacking operation to the GCWW for approval. The Engineer will provide control points for the casing installation. Install casing to conform to these control points. If there is any deviation in grade or alignment of the casing, which prevents the installation as designed or access for maintenance, re-install the casing in the proper manner.

Furnish and install approved water main casing insulators as specified in the GCWW Standard Drawings.

After the water main is installed, completely fill all voids between the outside of the pipe and the casing with pea gravel.

Close both ends of the casing with a four-inch (102 mm) brick or concrete bulkhead, or rubber boot.

When directed by the GCWW Inspector, install a four-inch (102 mm) drain in the bulkhead.

The Contractor is responsible for the bore pit excavations and the necessary support and maintenance of all utilities within the excavations.

Perform all restoration as specified.

1108.04 Measurement. GCWW will measure the actual number of linear feet (meters) of installed tunnel liner as measured along the center line of the water main.

1108.05 Basis of Payment. Payment is full compensation for labor, material, and equipment necessary to install the casing as herein specified.

GCWW will make compensation for the installation of the water main within the steel casing under the appropriate Item 1101.

When the GCWW Inspector orders sheeting and bracing to remain in casing shafts or pipe trenches, compensation will be made under Item 637 of this Supplement.

GCWW will pay for accepted quantities at the Contract prices as follows:

Item	Unit	Description
1108	Linear Foot (meter)	Furnishing and Installing ___" Steel Casing

Item 1109 Excavating For Tapping Sleeve and Valve

1109.01	Description
1109.02	Construction
1109.03	Measurement
1109.04	Basis of Payment

1109.01 Description. This work covers the excavation of a pit in accordance with the dimensions shown on GCWW Standard Drawings, backfilling, compaction, and restoration.

1109.02 Construction. Make the excavation in accordance with the GCWW Standard Drawings and conform to the pertinent references in 1101.04.

GCWW will install the tapping sleeve and valve and tap the water main.

Construction of the chamber, if required, will be compensated for under Item 1111. If a valve box is installed, it will be paid for under Item 1116.

Properly backfill the excavation and perform the necessary restoration.

1109.03 Measurement. GCWW will measure Excavating for Tapping Sleeves and Valves by the number of each excavation completed and accepted.

1109.04 Basis of Payment. GCWW will pay for accepted quantities at the Contract prices as follows:

Item	Unit	Description
1109	Each	Excavating for ___" (cm) x ___" (cm) Tapping Sleeve and Valve

Item 1110 Concrete

1110.01	Description
1110.02	Materials
1110.03	Construction
1110.031	Structures
1110.032	Backfill Concrete

- 1110.033 High-Early Concrete**
- 1110.04 Measurement**
- 1110.05 Basis of Payment**

1110.01 Description. This item covers furnishing and placing the various classes of concrete listed in 1110.02, in the necessary formwork, in accordance with these specifications, as shown on the Plans or as directed by the GCWW Inspector.

1110.02 Materials. Materials shall be as follows:

11

10.021 Concrete Class QC1 – 499.

1110.022 High-Early Concrete Class QC1 – 499. except Portland Cement shall conform to 701.02 and 701.05.

1110.023 Concrete Class "T" – one part Portland Cement (701.04), four parts of sand (703.02); eight parts of gravel (703.02); and 4.75 gallons (18.0 litres) of water per sack of cement.

1110.03 Construction. Construction shall be as follows:

1110.031 Structures. Use Concrete Class QC1 - 1110.021 or 1110.022 for all concrete to be used in constructing piers, pipe protections, blocking, remodeling chambers and for any other purpose necessary for satisfactory completion of the work. All concrete construction shall be governed by the detailed drawings, GCWW Standard Drawings, or as directed by the GCWW Inspector.

Blocking of pipe specials requires the placing of concrete between the water main and the limits of the trench, in a manner to assure the proper distribution of forces to undisturbed earth where possible.

The provisions of Item 511 apply to this item with the following exceptions: 511.15, 511.16, 511.17, 511.18, 511.19, 511.20, 511.21, 511.22, 511.23, and 511.24.

1110.032 Backfill Concrete. Use Concrete, Class "T", for backfill in areas designated on the Plans or where directed by the GCWW Inspector.

1110.033 High-Early Concrete. Use High-Early Concrete as a substitute for Concrete, Class QC1 1110.031 only when conditions warrant and with the permission of GCWW Inspector. Adhere to all provisions of 1110.031

1110.04 Measurement. GCWW will measure concrete by the number of cubic yards (cubic meters), as determined by calculation from structure dimensions (or backfill dimensions), in place, completed and accepted.

Calculation of concrete used in blocking will only be considered for a distance of 12 inches (305 mm) from the outside of the pipe on the thrust side of pipe special, unless otherwise shown on the Plans or GCWW Standard Drawings.

1110.05 Basis of Payment. Payment is full compensation for all labor, material, formwork, and equipment required to complete the work as herein specified.

Compensation for concrete used in the construction of Water Works Chambers is included in Item 1111.

Compensation for reinforcing steel is included in Item 509.

GCWW will pay for accepted quantities at the Contract prices as follows:

Item	Unit	Description
1110	Cubic Yards (m ³)	Concrete, Class "QC1"
1110	Cubic Yards (m ³) Strength	Concrete, Class "QC1" High-Early
1110	Cubic Yards (m ³)	Concrete, Class "T"

Item 1111 Water Works Chambers

- 1111.01 Description**
- 1111.02 Materials**
- 1111.03 Construction**
- 1111.031 Brick Masonry Construction**
- 1111.032 Poured Concrete Walls, Slabs and Floors**
- 1111.033 Precast Chambers**
- 1111.04 Measurement**
- 1111.05 Basis of Payment**

1111.01 Description. This item covers the labor, material, and equipment required to excavate and construct brick masonry, poured concrete, and precast Water Works Chambers.

1111.02 Materials. Furnish materials conforming to:

Concrete.....	1110.021
Concrete Bricks	704.02
Masonry Cement	701.07
Fine Aggregate.....	703.03
Manhole Steps.....	City of Cincinnati
	Division of Purchasing
	Spec. No. 11-14 (latest revision)
Castings and Covers	Furnished by Contractor (must meet

Construct brick walls to a thickness called for on the Plans or GCWW Standard Drawings. Thoroughly wet bricks before laying in mortar. Lay up the bricks with full mortar joints. Use a mortar mix composed of one part of Portland Cement 701.07, and two parts of sand 703.03 by volume. Mix the materials dry until the color is uniform; then add water and continue mixing until a stiff homogeneous mass is produced. Thoroughly mix all mortar in suitable watertight boxes or in approved mechanical mixers. Mix mortar in small quantities so that each batch may be used before it has taken its initial set. The use of lime in the mortar and the use of re-tempered mortar is not permitted. Re-tempered mortar is that which has been remixed with or without the addition of water after the initial set has taken place. Lay each successive course of brick in a full bed of mortar. Lay all bricks truly horizontal except in structures that are built to a fixed grade.

In general, lay bricks with push joints. Entirely fill the joints with mortar. The interior joints should not be more than 1/4 inches (6.4 mm) wide. Lay

1111.03 Construction. Construct new chambers in accordance with the GCWW Standard Drawings or as detailed in the GCWW Plans.

Make all excavations necessary to construct chambers. After the excavation has been made, and the sides securely supported where necessary, carefully hand-trim and shape the bottom of the excavation to conform to the outside of the proposed structure. Place a suitable concrete floor, as shown on GCWW Standard Drawings or detailed Plans, to form a foundation for the chamber.

1111.031 Brick Masonry Construction. Remove all mud and water from the foundation before laying brick. Use only brick that is clean and entirely free from dirt, paint, grease, and all other foreign substance.

Spread a layer of mortar, one-half inch (13 mm) thick, upon the prepared foundation. Set clean wet brick on the mortar. Use GCWW hydrant water for mixing mortar and wetting bricks. All brick with broken joints both on the sides and with the course below, and the masonry shall be thoroughly bonded together. Use whole bricks only. Use bats only to fill interstices and to effect closures. When required, anchor manhole steps in the masonry as the wall is laid up, in the manner shown on the GCWW Standard Drawings. Neatly point up the interior joints and clean the surface of all surplus mortar. Entirely fill the outside joints with mortar.

Backfill around the brick wall as quickly as possible following the completion of the brickwork.

1111.032 Poured Concrete Walls, Slabs, and Floors. Construct poured concrete walls, slabs, and floors as shown on the approved Plans or the GCWW Standard Drawings. Conform to 1110.021 for Concrete Class QC1.

Batching and Mixing. Unless otherwise approved by the GCWW Director, use an acceptable ready-mixed concrete supplier.

Consistency. Use concrete with a consistency suitable for the placement conditions with aggregates floating uniformly throughout the mass. The concrete must flow sluggishly when vibrated or spaded. Maintain a uniform slump.

Delivery Tickets. Provide a delivery ticket for each load of ready-mixed concrete. Coordinate with the truck operator to provide a copy of each ticket to the GCWW Inspector at the time of delivery.

Placement. Handling, depositing, and compacting concrete is subject to adjustment by the GCWW Inspector depending on weather and placement conditions.

With the approval of the GCWW Inspector, predetermine the limits of each concrete pour. Deposit all concrete within such limits in one continuous operation.

Before placing concrete, rigidly secure the forms, reinforcements, water stops, anchor bolts and embedments in proper position. Remove all dirt, mud, water, and debris from the space to be occupied by the concrete. Clean all surfaces encrusted with dried mortar or concrete from previous placement operations.

Conveyance and Distribution. Convey concrete to the point of final deposit by methods that will prevent segregation or loss of ingredients. Deposit concrete in final position without moving laterally in the forms more than 5 feet (1.5 meters).

Depositing Concrete. Deposit concrete in horizontal layers of proper depth for effective compaction. Do not exceed 24 inches (610 mm) on any layer. Each layer of concrete shall be plastic when covered with the following layer. Fill forms at a rate of vertical rise of not less than 2 feet (610 mm) per hour.

Deposit and compact concrete in wall forms before placing reinforcing. Do not exceed 6 feet (1.8 meters) of vertical height on the portion of any wall placed monolithically with a floor or roof slab. Allow concrete in walls to settle at least two hours before placing concrete in the structural system to be supported by such walls.

Thoroughly settle concrete when top finished. Remove all laitance, debris, and surplus from concrete surfaces at tops of forms by screeding, scraping, or other effective means.

Compaction. During and immediately after depositing, thoroughly compact all concrete and work concrete around all reinforcements and embedment and into the corners of the forms.

Compact all concrete with mechanical vibrators that will maintain at least 9000 cycles per minute when immersed in the concrete and are driven by not smaller than a 1-1/2 hp (1.1186 kW) motor. The number and type of vibrators are subject to the approval of the GCWW Director.

Tests of Concrete. If required by the GCWW Director for test purposes, make, care for, and store cylinders or other shapes of concrete for test purposes. Furnish all materials and forms. The GCWW will make all tests on such concrete specimens at no cost to the Contractor, unless otherwise specified on the Plans.

Provide the services of a helper whenever assistance is required in making other specified tests.

Reinforcement. Accurately form reinforcements and remove loose rust, scale, or other matter that reduces bond. Conform to Item 509 "Reinforcing Steel."

Placement. Position reinforcement on supports, spacers, hangers or other reinforcements and secure in place with wire ties or suitable clips.

Forms. Use forms designed to produce hardened concrete having the shape, lines, and dimensions shown on the Plans. Construct and maintain forms in proper position and accurate alignment.

Where concrete is placed against rock, remove all loose pieces of rock and clean exposed surfaces with a high-pressure hose.

Design. Forms shall be substantial and sufficiently tight to prevent leakage of mortar. Brace or tie forms to maintain the desired position, shape, and alignment during and after placing concrete. Size and space walers, studs, internal ties, and other form supports without exceeding proper working stresses.

Form Ties. Use GCWW approved removable end, permanently embedded body type form ties with a sufficient strength and rigidity to support and maintain the form in proper position and alignment without the use of auxiliary spreaders. Outer ends of the permanently embedded portion shall be at least one inch (25 mm) back from the concrete face. Construct permanently embedded portions of form ties, not provided with threaded ends, so that the removable ends are readily broken without damage to the concrete or concrete surface.

Form Removal. Do not remove or disturb forms until the concrete has attained sufficient strength to safely support all dead and live loads. Maintain shoring beneath beams or slabs and reinforce, as necessary, to carry any construction equipment or materials placed thereon. Avoid surface gouging, corner or edge breakage, and other damage to the concrete when removing forms.

Finishing Formed Surfaces. Fill recesses from form ties flush with mortar. Remove fins and other surface projections from all formed surfaces except exterior surfaces in contact with earth backfill. If necessary, use a power grinder.

Finishing Unformed Surfaces. Surface treatment is not required for buried or permanently submerged concrete except that required to obtain the surface elevations or contours and surfaces free of laitance. Screed the unformed surfaces of all other concrete. Provide an initial float finish followed by additional floating.

Screeding. When screeding, provide a concrete surface conforming to the proper elevation and contour, with all aggregates completely embedded in mortar. Eliminate irregularities on all screeded surfaces.

Floating. Give screeded surfaces an initial float finish as soon as the concrete has stiffened sufficiently for proper working. Remove any piece of coarse aggregate that is disturbed by the float or causes a surface irregularity and replace with mortar. Initial floating shall produce a surface of uniform texture and appearance with no unnecessary working of the surface.

Curing. Protect the concrete from loss of moisture for at least seven days after placement, unless otherwise approved by the GCWW Director.

Keep the concrete surfaces adequately wet during the specified curing period.

Backfill. After removal of all formwork and proper curing of the concrete, backfill around the completed chamber with backfill gravel.

1111.033 Precast Chambers. Furnish and install Precast Reinforced Concrete Chambers in accordance with Item 706.13. Conform to all pertinent provisions of this item and applicable GCWW Standard Drawings. Use precast chambers in all locations where space permits and as directed by GCWW. Chambers require material certification prior to installation. Manufacturers of precast chambers must be approved by GCWW.

1111.04 Measurement. GCWW will measure Valve Chambers by the number of each size and type, completed and accepted.

1111.05 Basis of Payment. Payment is full compensation for work done under this item for all labor, material, and equipment required to build or set the chamber, and to perform restoration, as herein specified.

In the event that the height of any chamber exceeds the depth shown on the GCWW Plans, GCWW will compensate the Contractor under Item 602 for the additional depth of brick and Item 1110 for poured concrete chambers.

If no profile or note is shown on the Plans specifying the depth of chambers, then the depths shown in the GCWW Standard Drawings shall prevail, and additional depths paid as indicated above.

GCWW will compensate for reinforcing steel ordered by the GCWW Inspector, in addition to that specified on the GCWW Standard Drawings or details on the Plan, under 509 "Reinforcing Steel."

GCWW will pay for accepted quantities at the Contract prices as follows:

Item	Unit	Description
1111	Each	___" (cm) x ___" (cm) Tapping Valve Chamber
1111	Each	___" (cm) Valve Chamber
1111	Each	___" (cm) Laydown Valve Chamber
1111	Each	___" (cm) Manhead Chamber
1111	Each	___" (cm) Aircock Chamber on ___" (cm) Water Main
1111	Each	___" (cm) x ___" (cm) Flanged Outlet Valve Chamber
1111	Each	___" (cm) Butterfly Valve Chamber

Item 1112 Hauling and Installing Fire Hydrants

1112.01	Description
1112.02	Furnishing of Fire Hydrants
1112.03	Installation of Fire Hydrants
1112.04	Measurement
1112.05	Basis of Payment

1112.01 Description. This item covers the hauling and installing of new fire hydrants where indicated on the GCWW Plans, or as directed by the GCWW Inspector.

1112.02 Furnishing of Fire Hydrants. Furnish fire hydrants as specified in City of Cincinnati Division of Purchasing Specification 10-107, or latest revision thereof.

Where specifically noted on the Plans, GCWW will furnish fire hydrants. Obtain these new fire hydrants at the GCWW yard at 4747 Spring Grove Avenue.

1112.03 Installation of Fire Hydrant. Haul the new hydrants from the source of supply and store them at the job site. Make the proper excavation and connect the new hydrant to the pipe as shown on the GCWW Standard Drawings or as directed by the GCWW Inspector.

Firmly set the hydrant on two 6 inch x 12 inch x 2 inch (152 mm x 305 mm x 51 mm) oak blocks. Install concrete blocking within the area between the back of the hydrant shoe and the undisturbed earth as shown on the GCWW Standard Drawings and as directed by the GCWW Inspector. Set the hydrant vertical, rotate the fire hydrant shoe when necessary, and properly orient the nozzles to the curb line.

Concrete used for blocking will be paid for under Item 1110.

The trench shall be backfilled with the proper material as designated in 1101.07.

When required, install guard posts and/or drainpipe to protect the fire hydrant. See GCWW Standard Drawing 103-1 and 103-1A.

Perform all restoration as specified on the Plans or as required by the agency of jurisdiction.

1112.04 Measurement. GCWW will measure Installing Fire Hydrants or Flush Hydrants by the number of each completed and accepted.

1112.05 Basis of Payment. Payment is full compensation for work done under this item for all labor, material, and equipment required to install the hydrants as herein specified.

GCWW will pay for accepted quantities at the Contract prices as follows:

Item	Unit	Description
1112	Each	Hauling & Installing Fire Hydrants
1112	Each	Furnishing & Installing Fire Hydrants

Item 1113 Relocating Existing Fire Hydrants

1113.01	Description
1113.02	Construction
1113.03	Measurement
1113.04	Basis of Payment

1113.01 Description. This item covers furnishing of all labor, tools, material, and equipment necessary to relocate an existing fire hydrant to a new location as shown on the GCWW Plans or as directed by the GCWW Inspector.

1113.02 Construction. Excavate and carefully disconnect the fire hydrant from the existing pipe. Wire brush and thoroughly clean the joint. Remove existing pipe and plug the existing tee, if necessary. Install all new pipe and fittings required to set the hydrant to the proper grade and alignment.

Conform to the pertinent provisions of 1112.03.

Compensation for all new pipe and fittings installed will be under Item 1101.

Compensation for plugging existing tees and mains will be under Item 1105.

Perform all restoration as specified on the Plans or as required by the agency of jurisdiction.

1113.03 Measurement. GCWW will measure Relocating Existing Fire Hydrants by the number of each completed and accepted.

1113.04 Basis of Payment. Payment is full compensation for all labor, tools, material, and equipment necessary to relocate fire hydrants as herein specified.

GCWW will pay for accepted quantities at the Contract prices as follows:

Item	Unit	Description
1113	Each	Relocating Existing Fire Hydrants

Item 1114 Removing Fire Hydrants

1114.01

Description

1114.02

Construction

1114.03

Measurement

1114.04

Basis of Payment

1114.01 Description. This item covers the removing of fire hydrants when they are not to be relocated.

1114.02 Construction. Make the necessary excavation, cut out the old pipe, carefully remove the complete hydrant intact, (shoe to operating nut), bulkhead seal existing fire hydrant lead. Completely backfill the opening, restore all disturbed surfaces, and return the hydrant to the governing agency.

All new pipe and fittings will be paid for under Item 1101. Plugging of existing tees or mains will be compensated for under Item 1105.

If the fire hydrant is to be abandoned and eliminated by paving or grading operations, no payment will be made.

Perform all restoration as specified on the GCWW Plans or as required by the agency of jurisdiction.

1114.03 Measurement. GCWW will measure Removing Fire Hydrants by the number of each completed and accepted.

1114.04 Basis of Payment. Payment is full compensation for all labor, tools, material, and equipment necessary to remove fire hydrants as herein specified.

GCWW will pay for accepted quantities at the Contract prices as follows:

Item	Unit	Description
1114	Each	Removing Fire Hydrants

Item 1115 Furnishing and Installing Fire Hydrant Extensions

1115.01

Description

1115.02

Materials

1115.03 Measurement

1115.04 Basis of Payment

1115.01 Description. This item covers the furnishing of all labor, tools, material, and equipment necessary to furnish and install fire hydrant extensions of the length required. This work includes drilling the stem, installing the pin, and reassembly of the hydrant where required, or as directed by the GCWW Inspector.

Perform all restoration as specified on the GCWW Plans or as required by the agency of jurisdiction.

Install no more than one fire hydrant extension on any hydrant setting. Limit length of fire hydrant extension to 2 feet or less. Raise hydrants requiring more than 2 feet of extension by use of S-bends or 2 mechanical joint bends of the appropriate degree.

1115.02 Materials. Furnish fire hydrant extensions, consisting of spool and stem extensions, conforming to the specifications of the GCWW (see Drawing No. 438M) and of the necessary length to adjust the hydrant to the proper elevation.

1115.03 Measurement. GCWW will measure Fire Hydrants Extensions by the number of each size and length completed and accepted.

1115.04 Basis of Payment. Payment is full compensation for all labor, tools, material, and equipment necessary to install fire hydrant extensions as herein specified.

GCWW will pay for accepted quantities at the Contract prices as follows:

Item	Unit	Description
1115	Each	Furnishing and Installing Fire Hydrant Extensions ____" (cm) Long

Item 1116 Installing Valve Boxes Complete

1116.01	Description
1116.02	Material
1116.03	Construction
1116.04	Measurement
1116.05	Basis of Payment

1116.01 Description. This item covers the installation of valve box hoods, lids, and telescopes, where shown on the GCWW Plans or directed by the GCWW Inspector.

1116.02 Material. All valve boxes for mains 12" and smaller, shall be the screw type Tyler Union 6850, East Jordan Iron Works Series 8550, or approved equal. All valve box components shall be domestically manufactured.

All valve boxes for mains 16" and larger shall be East Jordan Iron Works Series Number 460-462, Ninnah Foundry E125, or approved equal. All valve box components shall be domestically manufactured.

All valve boxes for mains 12" and smaller shall incorporate the use of a "BOXLOK Device" and "Frost Plug" manufactured by EMMA Sales, LLC or an approved equal. For mains 16" and larger only the use of the "Frost Plug" is required.

1116.03 Construction. Make the necessary excavation and install the telescopes in a vertical position directly over the valve stem.

Backfill the excavation to the proper elevation so that the valve box can be set to the proper grade.

For mains 16" and larger, set the valve box hood on a wood block or brick foundation to prevent the transferring of any loads from the hood to the valve.

Use of a plastic valve box is required in all sidewalk and within cross walk installations. Use of a plastic valve box will not be permitted for any other applications.

1116.04 Measurement. GCWW will measure Valve Boxes Complete by the number completed and accepted.

1116.05 Basis of Payment. Payment is full compensation for all labor, tools, material, and equipment necessary to install valve boxes as herein specified.

GCWW will pay for accepted quantities at the Contract prices as follows:

Item	Unit	Description
1116	Each	Installing Valve Boxes Complete
1116	Each	Furnishing and Installing Valve Boxes Complete
1116	Each	Furnishing and Installing Valve Boxes with ___" Air Release Complete, See Detail on Plans

Item 1117 Field Welding Tied Joints, Concrete Pipe

1117.01	Description
1117.02	Materials
1117.03	Construction
1117.04	Measurement
1117.05	Basis of Payment

1117.01 Description. This item covers field welding those joints of reinforced concrete pressure pipe required to be tied on the laying schedule or on the GCWW Plans.

1117.02 Materials. Furnish all material necessary to complete the operation, including filler rods.

1117.03 Construction. Delegate a certified welder to join the tied pipe in the manner indicated on the GCWW Standard Drawings.

Properly place filler rods and perform tack welding in the gap between spigot and bell rings.

Filling welds, 1/4 inch (6.4 mm), shall be of a quality and penetration to develop the full strength of the bell ring. Make welds 360 degrees in series of six inch (152 mm) long intermittent welds to avoid overheating gasket.

1117.04 Measurement. GCWW will measure Field Welding Tied Joints by the number completed and accepted per size of pipe diameter.

1117.05 Basis of Payment. Payment is full compensation for all labor, material, and equipment necessary to complete the operation as herein specified.

GCWW will pay for accepted quantities at the Contract prices as follows:

Item	Unit	Description
1117	Each	Field Welding Tied Joints ___" (cm) Diameter

Item 1118 Salvaging Existing Water Mains and Fittings

1118.01	Description
1118.02	Salvaging Procedures

- 1118.021 Concrete Pipe and Fittings**
- 1118.022 Steel Pipe and Fittings**
- 1118.023 Ductile Iron Pipe and Fittings**
- 1118.03 Measurement**
- 1118.04 Basis of Payment**

1118.01 Description. This item covers salvaging existing pipe and fittings where shown on the GCWW Plans, or as directed by the GCWW Director, and the cleaning, repairing, and storing of such on the project.

1118.02 Salvaging Procedures. Make the excavation, disconnect the pipe and fittings, remove the pipe and fittings from the trench, and renovate in the appropriate manner listed below:

1118.021 Concrete Pipe and Fittings.

- A. Remove grout from joint.
- B. Flame wash tied pipe and specials to separate bell ring from the filler rod. Grind bell ring smooth and round all sharp edges to 1/16 inch (1.6 mm) radius.
- C. Disconnect pipe joint and carefully remove pipe and specials from the trench.
- D. Patch any damage to lining or coating with a proper cement mixture to match original material.
- E. Flush the concrete pipe and specials with a hose and wire brush to the satisfaction of the GCWW Inspector.

11

18.022 Steel Pipe and Fittings.

- A. Disconnect the couplings and carefully remove the pipe and fittings from the trench.
- B. Flush inside and outside with a hose.
- C. Patch any damage to coating or lining with same type of material as was used in original fabrication.

1118.023 Ductile Iron Pipe and Fittings.

- A. Disconnect joints in pipe and fittings and carefully remove pipe.
- B. Thoroughly flush with a hose and wire brush both inside and outside.
- C. Patch any cracks in cement lining in a suitable manner.

D. Paint outer surface of pipe and fittings with an approved paint as ordered by the GCWW inspector.

Properly backfill and thoroughly compact all trenches and restore all disturbed surfaces.

After the material has been cleaned to the satisfaction of the GCWW Inspector, store it at another location within the limits of the project, so that it may be re-laid, or hauled to a GCWW Distribution Storage Yard.

If the pipe is re-laid on the project, the Contractor will be compensated for the work associated with salvaging under Item 1101.

If the material is returned to the GCWW Distribution Storage Yard, the Contractor will be compensated under Item 1102.

1118.03 Measurement. GCWW will measure the actual laying length of salvaged water mains and fittings along the centerline of the water pipe.

1118.04 Basis of Payment. Payment is full compensation for all labor, material, and equipment required to salvage pipe and fittings as herein specified.

GCWW will pay for accepted quantities at the Contract prices as follows:

Item	Unit	Description
1118	Lineal Foot (meter)	Salvaging Existing ____" (cm) Water Mains and Fittings

Item 1119 Additional Excavation

1119.01 Description

1119.02 Construction Requirements

1119.03 Method of Measurement

1119.04 Basis of Payment

1119.01 Description. Additional excavation consists of excavation necessitated by a change in specified profile grade or unused trench because of changes in alignment ordered by the GCWW Inspector. Include compensation for additional excavation required to remove unsuitable soil under this item.

Except as compensated by this item, there will be no additional compensation for rock excavation necessitated by a change in grade or alignment.

1119.02 Construction Requirements. Excavate to the specified lower grade or altered alignment. Conform to all of the requirements of Items 1100 and 1101.

1119.03 Method of Measurement. GCWW will measure Additional Excavation by the volume (cubic yards or meters) of material in its original position prior to excavation as determined by field measurements.

The depth considered by a change in the specified profile grade is the depth below the bottom of the trench as shown on the plan profile when available. Otherwise, the depth considered is the nominal depth as specified in 1101.04. Trench width considered will be as specified in 1101.04.

The depth considered in the event of unused trench is the actual depth from the existing grade to the bottom of the trench. Trench width will be as specified in 1101.04.

Additional backfill required because of additional excavation is also compensated for in this item.

1119.04 Basis of Payment. Payment is full compensation for all labor, material, and equipment required for the additional excavation as herein specified.

GCWW will compensate the Contractor for restoration of any unused trench. This Item does not cover excavation included as part of any other Contract item.

GCWW will pay for accepted quantities at the Contract prices as follows:

Item	Unit	Description
1119	Cubic Yard (meter)	Additional Excavation

Item 1120 Exploratory Excavation

1120.01	Description
1120.02	Materials
1120.03	Construction Requirements
1120.04	Method of Measurement
1120.05	Basis of Payment

1120.01 Description. This item covers the excavation of test holes that are of an exploratory nature as directed by the GCWW Inspector. This item includes excavations necessary to determine locations of GCWW facilities, existing piping materials, locations of any utility facilities, or any other excavation designed to obtain information that will aid the progress of the project. This item does not include excavations within the limits of the proposed trench as defined in 1101.04 and 1101.05. Test holes are required on all utilities within 50 feet (15.2 m) of the last laid pipe. Test holes within the alignment of the proposed trench are included in the Contractor's unit bid for Item 1101.

1120.02 Materials. Use material for backfilling that conforms to 1101.07, "Laying Pipe and Fittings - Backfilling." Use material for restoration that conforms to the requirements of the governing agency and comply with the restoration details on the approved GCWW Plans.

1120.03 Construction Requirements. Remove any sidewalk, street pavement, sod, or any other surface; excavate to determine the information for which the excavation was made; and backfill the excavation. Perform excavation by hand digging or by a mechanical means. Restore the excavated area upon completion of the test hole.

1120.04 Method of Measurement. GCWW will measure Exploratory Excavation by the volume of material (cubic yards or meters) in its original position prior to excavation as determined by field measurements.

Sidewalks, street pavement, sod, or any other surface will be included in this measurement.

1120.05 Basis of Payment. Payment is full compensation for all labor, material, and equipment required for exploratory excavation as herein specified.

Locations to be explored will vary from areas within the roadway to areas outside of the roadway. Consider this in preparation of the unit bid.

This item does not cover excavation that is included as part of any other Contract items.

GCWW will pay for accepted quantities at the Contract prices as follows:

Item	Unit	Description
1120	Cubic Yard. (m ³)	Exploratory Excavation

Item 1121 Filling Abandoned Water Works Structures

1121.01	Description
1121.02	Materials
1121.03	Construction
1121.04	Method of Measurement
1121.05	Basis of Payment

1121.01 Description. This item covers the labor, material, and equipment required to abandon existing Water Works structures as indicated on the GCWW Plans or as directed by the GCWW Inspector.

1121.02 Materials. Use Controlled Low Strength Mortar backfill material (GCWW approved) for this operation. See 1101.071.

1121.03 Construction. Structures that are to be abandoned as a part of this project will be so noted on the Plans. All castings abandoned become the property of the Contractor. Remove abandoned castings from the job site.

The Contractor shall remove the walls to three (3) feet below pavement and break up the existing floor.

Backfill all remaining cavities with the proper material specified above.

1121.04 Method of Measurement. GCWW will measure Filling Abandoned Water Works Structures by the volume of backfill (cubic yards or cubic meters) required to fill the resulting cavities to the subgrade or ground surface.

1121.05 Basis of Payment. Payment is full compensation for all labor, material, and equipment required to perform the work as herein specified.

GCWW will pay for accepted quantities at the Contract prices as follows:

Item	Unit	Description
1121	Cubic Yards (cubic meters)	Filling Abandoned Water Works Structures

Item 1122 Removing Existing Manhole Curbs and Covers and Valve Boxes

- 1122.01 Description**
- 1122.02 Materials**
- 1122.03 Construction**
- 1122.04 Method of Measurement**
- 1122.05 Basis of Payment**

1122.01 Description. This item covers the labor, material and equipment required to remove existing manhole curbs and covers or valve boxes that are located in sod, pavement, or sidewalks , backfilling all remaining cavities and permanent restoration of surface.

1122.02 Materials. Use Controlled Low Strength Mortar flowable fill material (GCWW approved) for this operation. See 1101.071.

1122.03 Construction. Remove existing manhole curbs and covers or valve boxes, including the telescope, when so directed by the GCWW Inspector. When the structure extends into the upper foot of the finished subgrade or ground surface, remove at a minimum of one foot below these limits. All castings abandoned become the property of the Contractor. Remove all castings from the Project.

Backfill the abandoned structure as described in 1122.02

Restore the disturbed pavement, sod, driveways or sidewalks so it conforms to the adjacent surface. Restore concrete walks or driveways from joint to joint.

1122.04 Method of Measurement. GCWW will measure Removing Existing Manhole Curbs and Covers and Valve Boxes by the number of each completed and accepted. When the backfill material of each manhole curb and cover removed exceeds two cubic yards, GCWW will compensate the Contractor for all additional material under Item 1121.

1122.05 Basis of Payment. Payment is full compensation for all labor, material and equipment necessary to perform the work herein specified.

GCWW will pay for accepted quantities at the Contract prices as follows:

Item	Unit	Description
1122	Each	Removing Existing Manhole Curbs and Covers
1122	Each	Removing Existing Valve Boxes

Item 1123 Changing Pipe Sewers

1123.01	Description
1123.02	Materials
1123.03	Construction
1123.04	Measurement
1123.05	Basis of Payment

1123.01 Description. This item covers furnishing all labor, material, tools, and equipment required to change the grade or alignment of pipe sewers and laterals of various sizes, allowing installation of water mains and appurtenances as shown on the GCWW Plans, or as directed by the GCWW Inspector.

GCWW has made every effort to depict the pipe sewer and lateral information on the Plans. When encountering a pipe sewer or lateral (not shown on the Plans) in the excavation requiring a change of grade or alignment for the installation of the water main, the Contractor will be compensated for the work under this bid item.

This work includes all necessary excavation, backfill, and restoration.

1123.02 Materials. Furnish material that conforms to the specifications stated in Item 603 of this Supplement.

1123.03 Construction. Perform construction required for the changing of pipe sewers in a manner that conforms to Item 603 of this Supplement, or to the satisfaction of the political subdivision having jurisdiction.

Be responsible for all pipe sewers disturbed in the completion of this project. Restore all pipe sewers exposed to an equal or better condition when finished with the specific work.

Any sewer pipe that is broken or disturbed due to the Contractor's operations will not be paid for unless such pipe, of necessity, must be changed in alignment or grade to allow the installation of water mains and appurtenances.

1123.04 Measurement. GCWW will be the sole judge in determining the amount of linear feet (meters) of pipe changed.

GCWW will measure Changing Pipe Sewers by the actual length of linear feet (meters) for each appropriate size measured along the invert, from the beginning to the end of the new pipe installed.

1123.05 Basis of Payment. Payment is full compensation for all labor, material, tools, and equipment required to change the pipe sewers and laterals of various sizes as specified herein.

GCWW will pay for accepted quantities at the Contract prices as follows:

Item	Unit	Description
1123	Linear Foot (meter)	Changing Pipe Sewer

Item 1124 Furnishing, Installing, and Maintaining Temporary Water Mains

1124.01	Description
1124.02	Materials
1124.03	Construction
1124.04	Measurement
1124.05	Basis of Payment

1124.01 Description. This item covers furnishing, hauling, and installing of temporary water mains where specified on the GCWW Plans, or where directed by the GCWW Director and restoration of all disturbed areas.

1124.02 Materials. The Special Provisions of the Plans will contain detailed information concerning temporary water mains in those instances where no alternate material can be allowed.

When such information is not specified in the Special Provisions, submit to the GCWW Director, a proposed plan indicating the type of temporary piping to be used. The GCWW Director will approve, or disapprove, the proposed plan after considering the following data:

- A. Diameter of pipe.

- B. Pipe material. (New pipe or pipe previously used for potable water only.)
- C. Type of pipe joints.
- D. Method of installation.
- E. Sterilization provision.
- F. Adequate valving and fire hydrants.

GCWW will allow the Contractor to proceed with work only when, in the GCWW Director's opinion, the proposed plan meets the job requirements.

1124.03 Construction. Perform installation as indicated in the Special Provisions or as shown on the above-mentioned GCWW approved plan.

Remove the temporary water main from the jobsite when it is no longer needed.

Return water pipe furnished by the GCWW to the GCWW Distribution Storage Yard.

Perform all restoration as specified on the Plans or as required by the agency of jurisdiction.

1124.04 Measurement. GCWW will measure Temporary Water Mains by the total lineal feet (meters) of temporary water main installed including specials and fittings, as measured along the centerline of the temporary water main.

1124.05 Basis of Payment. GCWW will compensate the Contractor for temporary water mains specifically indicated on the Plans. Temporary water mains and service branches installed for the convenience of the Contractor, or such temporary work required to maintain adequate water for consumers and fire fighting purposes, will not be paid for. See 1101.053.

Payment is full compensation for all labor, material, and equipment to furnish, install, maintain, and removal the temporary water main as herein specified.

GCWW will pay for accepted quantities at the Contract prices as follows:

Item	Unit	Description
1124	Foot (meter)	Furnishing, Installing, and Maintaining Temporary Water Mains
1124	Foot (meter)	Installing and Maintaining Temporary Water Mains

Item 1125 Resetting Existing Valve Boxes Complete

- 1125.01 Description**
- 1125.02 Construction**
- 1125.03 Measurement**
- 1125.04 Basis of Payment**

1125.01 Description. This item covers resetting of existing valve box hoods, lids, and telescopes, where necessary to conform to the established lines and grades of the pavement.

1125.02 Construction. Make the necessary excavation and reset the telescope and hood to conform to 1116.02.

Do not reset existing valve boxes that are not in good condition, as determined by the GCWW Inspector. Install a new valve box in accordance with Item 1116.

When it is necessary to raise the hood over six inches (152 mm), remove the hood and place a new telescope, or portion thereof, over the existing telescope.

When it is necessary to lower the hood over six inches (152 mm), remove the hood and cut off the telescope as directed.

If any part of the valve box assembly is damaged or broken by the Contractor's operations, replace the damaged portion at no cost to the GCWW.

1125.03 Measurement. GCWW will measure Resetting Valve Boxes Complete by the number of each completed and accepted.

1125.04 Basis of Payment. Payment is full compensation for all labor, materials, and equipment required to complete the work as herein specified.

GCWW will pay for accepted quantities at the Contract prices as follows:

Item	Unit	Description
1125	Each	Resetting Existing Valve Boxes Complete

Item 1126 Installing and Connecting Copper Service Pipe

1126.01 Description

1126.02 Materials

1126.03 Construction

1126.04 Method of Measurement

1126.05 Basis of Payment

1126.01 Description. This item covers the installation of copper service pipe, of various sizes, where indicated on the GCWW Plans or as directed by the GCWW Inspector.

1126.02 Materials. Furnish all new service pipe and fittings required to complete the work as shown, unless otherwise indicated on the Plans. Submit material certification for copper pipe and fittings to GCWW prior to installation.

Wrap services with polyethylene in accordance with GCWW Standard Drawings 105-5 and 105-5A.

1126.03 Construction. Excavate the trench to provide 3-1/2 feet (1.07 meters) of cover over the water service.

Install the new pipe and fittings, make all necessary joints and connections, and properly backfill the trench, and complete restoration.

In the event that a copper to lead adapter does not fit the existing lead service pipe, furnish the necessary labor and material to wipe the joint. No additional payment will be made for a wiped joint.

Disconnect all existing service branches within the trench of the renewed service branch as described under Item 1130. If the existing ferrule is not within the same trench, GCWW will compensate to disconnect the existing service branch under Item 1130.

Remove or break out existing curb or roadway box. If the box is in a concrete walk, replace concrete walk block to block. If the box is in permanent roadway, remove the lid and fill the abandoned box with concrete and trowel finish. If the box is located in a dirt or sod area, remove or break out the entire top section of the box and backfill with earth.

New service branch installation for property not presently being served will be installed by the GCWW at locations, as the property owner may desire, upon proper application and payment of charges.

1126.04 Method of Measurement. GCWW will measure Installing Copper Service Pipe by the actual number of lineal feet (meters) of service pipe and fittings installed.

1126.05 Basis of Payment. Payment is full compensation for all labor, material and equipment required to perform the work as herein specified.

Include the hauling of service branch material furnished by GCWW in the unit price bid. No payment will be made under Item 1102.

GCWW will pay for accepted quantities at the Contract prices as follows:

Item	Unit	Description
1126	Lineal Foot (meter)	Hauling, Installing, and Connecting ____" (cm) Copper Service Pipe
1126	Lineal Foot (meter)	Furnishing, Installing, and Connecting ____" (cm) Copper Service Pipe

Item 1127 Lowering Existing Service Branches

- 1127.01 Description**
- 1127.02 Construction**
- 1127.03 Measurement**
- 1127.04 Basis of Payment**

1127.01 Description. This item covers the lowering of existing copper service branches, regardless of size, where shown on the GCWW Plans or as directed by the GCWW Inspector.

1127.02 Construction. Excavate the trench and lower the existing service branch to a minimum depth of 3-1/2 feet (1.07 m) below the finished surface. Cut the pipe, disconnect the ferrule, or stop cock, when necessary to perform the operation. Perform lowering in a careful manner.

Be responsible for any damage to the service branch that may occur during the lowering operation.

Firmly backfill the trench after the service branch has been lowered and adjusted to its final position.

If the elevation of the existing service branch indicates lowering is not necessary, GCWW will compensate for the excavation under Item 1120.

1127.03 Measurement. GCWW will measure Lowering Service Branches based on the total lineal feet (meters) of service branch lowered.

GCWW will compensate for additional new service pipe required in the lowering of any service under Item 1126. GCWW will compensate for resetting of the curb or roadway box under Item 1132.

1127.04 Basis of Payment. Payment is full compensation for all labor, material, and equipment required to perform the work as herein specified.

GCWW will pay for accepted quantities at the Contract prices as follows:

Item	Unit	Description
1127	Linear Foot (meters)	Lowering Existing Service Branches

Item 1128 Reconnecting Existing Copper Service Branches

- 1128.01 Description**
- 1128.02 Materials**
- 1128.03 Construction**

1128.04 Measurement
1128.05 Basis of Payment

1128.01 Description. This item covers reconnecting of existing service branches, including the installation of copper service pipe when required for grade differential, from one main to another where shown on the GCWW Plans or as directed by the GCWW Inspector.

Reconnects only apply when the newly installed water main crosses the existing service branch. Where the newly installed main does not cross the existing service branch, compensation will be made under Item 1126.

Locate the curb/roadway box serving the branch when reconnecting the service branch. Clean out any debris if existing curb/roadway box is blocked and not operational. Replace or reset, as directed by the GCWW Inspector, curb/roadway boxes not found or found to be broken, shifted, or not to grade. This work shall be paid for under Item 1131 or 1132, as applicable.

1128.02 Materials. Furnish all new service pipe and fittings required to complete the work as shown, unless otherwise indicated on the Plans. Submit material certification for service pipe and fittings prior to installation.

1128.03 Construction. Make all necessary excavations, disconnect the existing service branch from the old ferrule, and reconnect it to the new ferrule.

Furnish labor, tools, and material necessary to make the joints and to complete the reconnection.

In the event that a copper to lead adapter does not fit the existing lead service pipe, furnish the necessary labor and material to wipe the joint. No additional payment will be made for a wiped joint.

Install any new service pipe required to complete the reconnection.

Wrap services with polyethylene in accordance with GCWW Standard Drawings 105-5 and 105-5A.

Perform restoration of all disturbed surfaces.

1128.04 Measurement. GCWW will measure Reconnecting Service Branches by the actual number of each size completed and accepted.

1128.05 Basis of Payment. Payment is full compensation for all labor, material, and equipment required to perform the work as herein specified.

GCWW will pay for accepted quantities at the Contract prices as follows:

Item	Unit	Description
-------------	-------------	--------------------

1128	Each	Reconnecting Existing 5/8-inch thru 1-inch (15.9-mm to 25.4-mm) Service Branches
1128	Each	Reconnecting Existing 1-1/2-inch & 2-inch (38.1-mm to 50.8-mm) Service Branches

Item 1129 Installing Stop Cocks in Existing Lines

- 1129.01 Description**
- 1129.02 Materials**
- 1129.03 Construction**
- 1129.04 Measurement**
- 1129.05 Basis of Payment**

1129.01 Description. This item covers installing of stop cocks in existing service branches where shown on the GCWW Plans or as directed by the GCWW Inspector.

1129.02 Materials. Furnish all new service pipe and fittings required to complete the work as shown, unless otherwise indicated on Plans. Submit material certification for service pipe and fittings prior to installation.

1129.03 Construction. Make the necessary excavations, install the new stop cock where indicated, check the existing stop cock joints for tightness in the presence of the GCWW Inspector, firmly backfill the excavations, and restore all disturbed surfaces. This item shall include the installation of a short piece of copper pipe when necessary.

1129.04 Measurement. GCWW will measure Installing Stop Cocks In Existing Lines by the actual number of each size completed and accepted.

1129.05 Basis of Payment. Payment is full compensation for all labor, material, and equipment required to complete the work as herein specified.

Include the hauling of service branch material furnished by GCWW in the unit price bid. No payment will be made under Item 1102.

GCWW will pay for accepted quantities at the Contract prices as follows:

Item	Unit	Description
1129	Each	Hauling and Installing ____" (cm) Stop Cocks in Existing Lines
1129	Each	Furnish and Install ____" (cm) Stop Cocks in Existing Lines

**Item 1130 Disconnecting Existing Service Branches
5/8" (15.9 mm) Through 2" (50.8 mm)**

- 1130.01 Description**
- 1130.02 Construction**
- 1130.03 Service Branches with Service Saddles**
- 1130.04 Measurement**
- 1130.05 Basis of Payment**

1130.01 Description. This item covers disconnecting of existing service branches where required, removal of existing curb, roadway, or valve boxes, backfilling, and restoration of all surfaces. Branches to be disconnected are shown on the GCWW Plans or indicated by the GCWW Inspector.

1130.02 Construction. The GCWW Inspector will facilitate a scheduled shut down of the water main. Excavate down to the ferrule at the water main. Once the water main is shut down, disconnect the service line at the ferrule. Remove the ferrule from the water main and install a tapered brass plug supplied by the Contractor.

1130.03 Service Branches with Service Saddles. In those instances where a service saddle is part of the service branch, expose the connection to the water main, remove the service saddle, and furnish and install a stainless steel leak clamp. After the service line has been disconnected, backfill the excavation and perform permanent restoration.

Remove or break out existing curb, roadway, or valve box. If the box is in a concrete walk, or in permanent roadway, remove the lid and place a patch of concrete over the opening. If the box is located in a dirt or sod area, remove or break out the entire top section of the box and backfill with earth.

Perform restoration of the area surrounding the valve box conforming to the street restoration requirements of the appropriate political agency or as indicated on the Plans.

1130.04 Measurement. GCWW will measure Disconnecting Service Branches by the actual number of each completed and accepted.

Service branches disconnected when renewing service branches as part of Item 1126 will not be paid for if the ferrule is in the same trench.

1130.05 Basis of Payment. Payment is full compensation for all labor, and equipment required to perform the work as herein specified.

GCWW will pay for accepted quantities at the Contract prices as follows:

Item	Unit	Description
1130	Each	Disconnecting Existing 5/8-inch thru 2-inch (15.9-mm thru 50.8-mm) Service Branches

Item 1131 Installing Curb and Roadway Boxes

- 1131.01 Description**
- 1131.02 Construction**
- 1131.03 Measurement**
- 1131.04 Basis of Payment**

1131.01 Description. This item covers installing of curb or roadway boxes as indicated on the GCWW Plans or as directed by the GCWW Inspector.

1131.02 Construction. Make the necessary excavation, remove the old box if required, and set the new box in a vertical position directly over the stop cock. Set the base of the box on a wood block or brick foundation to prevent the transferring of any loads from the box to the service line. Adjust the box to the proper grade and carefully tamp the backfill around the box. Properly restore all disturbed surfaces.

1131.03 Measurement. GCWW will measure Installing Curb and Roadway Boxes by the actual number completed and accepted.

1131.04 Basis of Payment. Payment is full compensation for all labor, tools, materials, and equipment to complete the work as herein specified.

Include the hauling of any curb and roadway boxes furnished by GCWW in the unit price bid. No payment will be made under Item 1102.

GCWW will pay for accepted quantities at the Contract prices as follows:

Item	Unit	Description
1131	Each	Hauling and Installing Curb and Roadway Boxes
1131	Each	Furnishing and Installing Curb and Roadway Boxes

Item 1132 Resetting Existing Curb and Roadway Boxes

- 1132.01 Description**
- 1132.02 Construction**
- 1132.03 Measurement**
- 1132.04 Basis of Payment**

1132.01 Description. This item shall cover resetting existing curb and roadway boxes where necessary to conform to the established lines and grades of the street.

1132.02 Construction. Make the necessary excavation, reset the box in a vertical position directly over the stop cock, and adjust it to conform to the proper grade. Set the base

of the box on a wood block or brick foundation to prevent the transferring of any loads from the box to the service line. Firmly tamp around the box. Restore all disturbed surfaces.

Do not reset existing curb and roadway boxes that are in poor condition, as determined by the GCWW Inspector. Install new boxes, furnished by the GCWW, in conformance with the provisions of Item 1131 as part of unit bid price for Item 1132.

Furnish and Install new boxes at no expense to GCWW when existing boxes are damaged or broken by the Contractor's operations.

1132.03 Measurement. GCWW will measure Resetting Curb and Roadway Boxes by the actual number completed and accepted.

1132.04 Basis of Payment. Payment is full compensation for all excavation, material, backfill, restoration, and labor required.

GCWW will pay for accepted quantities at the Contract prices as follows:

Item	Unit	Description
1132	Each	Resetting Existing Curb and Roadway Boxes

Item 1133 Furnishing and Installing Frost-Proof Meter Settings Complete

- 1133.01 Description**
- 1133.02 Materials**
- 1133.03 Construction**
- 1133.04 Measurement**
- 1133.05 Basis of Payment**

1133.01 Description. This item covers the furnishing and installing of a standard frost-proof meter setting complete, as shown on the GCWW Plans or as directed by the GCWW Inspector.

1133.02 Materials. Furnish material that complies with the "Rules and Regulations of the GCWW" governing service branches and meter settings.

1133.03 Construction. Make the necessary excavations, connect the ends of service pipe, install the tile, hood, meter, and appurtenances to conform to the GCWW Standard Drawings "Rules and Regulations of the GCWW" in the proper location, backfill all openings, and restore all disturbed surfaces.

Set the meter box tile on bricks to prevent the transferring of any loads from the tile to the service line. Disconnect any sub-standard piping and install new service pipe.

1133.04 Measurement. GCWW will measure Furnishing and Installing Frost-Proof Meter Settings by the actual number of each size completed and accepted.

Any additional service pipe, other than that required to reconnect the ends of the branch where the original meter setting was removed, which must be installed to conform to the "Rules and Regulations of the GCWW" will be paid for under Item 1126.

1133.05 Basis of Payment. Payment is full compensation for all labor, material, and equipment required to perform the work as herein specified.

GCWW will pay for accepted quantities at the Contract prices as follows:

Item	Unit	Description
1133	Each	Furnishing and Installing ___" (cm) Frost-Proof Meter Setting Complete.

Item 1134 Relocating Existing Frost-Proof Meter Settings

- 1134.01 Description**
- 1134.02 Construction**
- 1134.03 Measurement**
- 1134.04 Basis of Payment**

1134.01 Description. This item covers furnishing all labor, tools, material, and equipment necessary to remove an existing frost-proof meter setting and relocate it to new location as indicated on the GCWW Plans or as directed by the GCWW Inspector.

1134.02 Construction. Make the necessary excavations, carefully remove the existing tile, hood, meter and appurtenances, relocate them in the new location specified, dispose of old yoke, furnish and install new yoke within meter setting, install a curb stop (if required). If no curb box exists, furnish and install new curb box. Backfill and restore all openings. Perform all work conforming to the requirements of 1133.03. Reconnect the service branch ends. Disconnect and replace any sub-standard piping.

1134.03 Measurement. GCWW will measure Relocating Existing Frost-Proof Meter Setting by the actual number of each size completed and accepted.

Any additional service pipe, other than that required to reconnect the end of the branch where original meter setting was removed, which must be installed to conform to "Rules and Regulations of the GCWW" will be paid for under Item 1126.

1134.04 Basis of Payment. Payment is full compensation for all labor, material, and equipment required to complete the work as herein specified.

GCWW will pay for accepted quantities at the Contract prices as follows:

Item	Unit	Description
1134	Each	Relocating Existing ____" (cm) Frost-Proof Meter Setting

Item 1135 Resetting Existing Frost-Proof Meter Settings

- 1135.01 Description**
- 1135.02 Construction**
- 1135.03 Measurement**
- 1135.04 Basis of Payment**

1135.01 Description. This item covers resetting of an existing frost-proof meter setting to the proper grade, where shown on the GCWW Plans or as directed by the GCWW Inspector.

1135.02 Construction. Make the necessary excavation, carefully remove the tile, hood, meter and its appurtenances, and add or remove any pipe and fittings to adjust the meter to the proper grade, and reset the tile and hood.

Set the meter box tile on bricks to prevent the transferring of any loads from the tile to the service line. Complete the installation conforming to the GCWW Standard Drawings.

1135.03 Measurement. GCWW will measure Resetting Existing Frost-Proof Meter Setting by the actual number of each size completed and accepted.

1135.04 Basis of Payment. Payment is full compensation for all labor, material, and equipment required to complete the work as herein specified.

GCWW will pay for accepted quantities at the Contract prices as follows:

Item	Unit	Description
1135	Each	Resetting Existing ____" (cm) Frost-Proof Meter Settings

Item 1136 Furnishing and Installing Frost-Proof Meter Setting Appurtenances

- 1136.01 Description**
- 1136.02 Materials**
- 1136.03 Construction**
- 1136.04 Measurement**
- 1136.05 Basis of Payment**

1136.01 Description. This item covers furnishing and installing of various frost-proof meter setting appurtenances as shown on the GCWW Plans or as directed by the GCWW Inspector.

1136.02 Materials. Furnish all appurtenances complying with the following descriptions:

Angle Valves - locking padlock wing on inlet valve and test cock on outlet valve. 5/8-inch through one-inch (15.9 mm through 25.5 mm).

Meter Yokes - 5/8-inch through one-inch (15.9 through 25.4 mm).

Flanged Angle Valves - flanged angle valves with padlock wing. - 1-1/2-inch through two-inch (38.1 mm through 50.8 mm).

Frost-Proof Meter Box - double-lid frost-proof meter box - 5/8-inch through two-inch (15.9 mm through 50.8 mm).

Lids - inner or outer (as specified) lids for frost-proof meter box - 5/8-inch through two-inch (15.9 mm through 50.8 mm).

Meter Box Tiles - vitrified, concrete, or approved Polymer frost-proof meter box tile, 20 inches (508 mm), 24 inches (610 mm), 30 inches (762 mm) diameter.

1136.03 Construction. Install the various appurtenances as required to conform to "Rules and Regulations of the GCWW" and GCWW Standard Drawings.

1136.04 Measurement. GCWW will measure each frost-proof meter setting appurtenance by the actual number of each size completed and accepted.

1136.05 Basis of Payment. Payment is full compensation for all labor, material, and equipment required to complete the work as herein specified.

GCWW will pay for accepted quantities at the Contract prices as follows:

Item	Unit	Description
1136	Each	Furnishing and Installing ___" (cm) Angle Valves
1136	Each	Furnishing and Installing ___" (cm) Meter Yokes
1136	Each	Furnishing and Installing ___" (cm) Flanged Angle Valves
1136	Each	Furnishing and Installing Lids for ___" (cm) Setting
1136	Each	Furnishing and Installing Double-Lid Frost-Proof Meter Box for ___" (cm) Setting

1136 Each Furnishing and Installing ___" (cm) Meter Box Tile

**Item 1137 Furnishing and Installing
Meter Settings (Domestic or Fire), Backflow Preventers,
and Appurtenances and Construct Pit**

- 1137.01 Description**
- 1137.02 Construction**
- 1137.03 Measurement**
- 1137.04 Basis of Payment**

1137.01 Description. This item covers furnishing and installing meter settings, backflow preventers, and any other related appurtenances and constructing the associated pit.

1137.02 Construction. As indicated on the GCWW Plans, furnish new meter settings, backflow devices, and any other associated appurtenances and install in a new pit in accordance with the appropriate GCWW Standard Drawing and as directed by the GCWW. These meter settings may be fire, domestic, or combination.

Furnish and install new meter settings and appurtenances that meet current GCWW Standards. Properly abandon the existing pit by removing the roof slab, sidewalls to a depth of four feet (1.22 meters) below the roof slab, and breaking up the pit floor. Properly backfill all voids and restore all disturbed areas conforming to project specifications.

1137.03 Measurement. GCWW will measure each by the actual number of each size completed and accepted.

1137.04 Basis of Payment. Payment is full compensation for all labor, material, and equipment required to complete the work as herein specified.

GCWW will pay for accepted quantities at the Contract prices as follows:

Item	Unit	Description
1137	Each	Furnishing and Installing ___" (cm) Fire and/or Domestic Meter Setting Complete and Construct Pit

Item 1138 Removing Curb and Roadway Boxes

- 1138.01 Description**
- 1138.02 Construction**
- 1138.03 Measurement**
- 1138.04 Basis of Payment**

1138.01 Description. This item covers removing existing curb and roadway boxes, backfilling, and restoration of all surfaces. Boxes to be removed are shown on the GCWW Plans or indicated by the GCWW Inspector.

1138.02 Construction. Remove the existing curb or roadway box to one foot (305 mm) below the existing surface. Restore the disturbed pavement, walk, driveway or sod so that it conforms to the adjacent surface. Restore concrete walks or driveways from joint to joint.

1138.03 Measurement. GCWW will measure Removing Curb and Roadway Boxes by the actual number of each completed and accepted.

1138.04 Basis of Payment. Payment is full compensation for all labor, material and equipment required to do the work as specified.

GCWW will pay for accepted quantities at the Contract prices as follows:

Item	Unit	Description
1138	Each	Removing Curb and Roadway Boxes

1300 INSTALLATION OF STREET LIGHTING EQUIPMENT AND TRAFFIC CONTROL DEVICES

The following Specifications and provisions apply to the construction of all Street Lighting and Traffic Control Systems.

Item 1301 Description

This specification covers the details of equipment, material, appurtenances and the labor necessary for the installation of a complete, first-class Street Lighting and/or Traffic Control System. This work covers the furnishing and installing all Lighting, Traffic Signal and Signing Equipment ready for service at the locations shown on the plan and in accordance with the details or as ordered by the City Traffic Engineer. The work also includes necessary excavation and backfill, disposal of discarded materials, restoration of disturbed facilities and surfaces and electrical testing as specified.

In addition, the work requires maintaining existing traffic and lighting facilities throughout the life of the Contract period. This also includes installation of any temporary lighting, traffic signals or signing where specified in the plans.

Equipment specified as being furnished by the City will be available as indicated herein and installed by the Contractor.

Item 1302 References

Wherever reference is made herein to any other specification or standard, it means the latest revision thereof in effect at the time of invitation to bid. This specification will govern where a reference specification and this specification disagree.

AASHTO numbers refer to the standards issued by the American Association of State Highway and Transportation Officials, Washington, D.C. 20001.

AISI numbers refer to standards of American Iron and Steel Institute, Washington, D.C. 20036.

ANSI refers to American National Standards Institute, Inc., New York, New York 10018.

ASTM numbers refer to designation numbers of standards issued by American Society for Testing and Materials, Philadelphia, Pennsylvania. 19103.

AWPA numbers refer to the specifications issued by the American Wood Preservers Association, Stevensville, Maryland. 21666.

AWS numbers refer to the specifications issued by the American Welding Society, Miami, Florida 33135.

1303 Materials

1303.01 Materials In General. All equipment and materials will be new, of first quality, of current design, proven in service, and free from defects and poor workmanship. Underwriters Laboratories, Inc. requirements apply to electrical equipment in general. The Institute of Transportation Engineers (ITE) requirements apply to traffic signal equipment. The National Electrical Code and local codes for the City of Cincinnati also apply to equipment and materials. Experimental or untried equipment is not acceptable.

All electrical parts, wire, switches and other elements of the installations require ample capacity to carry the required current without excessive heating or causing an excessive drop of potential.

Install a nameplate, indelible marking or brand identifying the type, model, catalog number and manufacturer on each individual item of equipment except as otherwise provided herein.

The City may request samples of equipment and materials supplied by the Contractor for testing and evaluation.

1303.02 Guarantee. Replace and install free of charge to the City, any material furnished by the Contractor that fails in any manner by reason of defective material or workmanship within a period of one year from the date accepted by the City, or the manufacturer's standard warranty, whichever is greater. Warrant performance as advertised and suitability for intended use.

1303.03 Damaged Materials. Be responsible to not scratch or damage the paint or galvanized finish on any materials or equipment installed. Touch up minor scratches with two

coats of a zinc-rich touch up paint matching the final paint color. The City will not accept major deep scratches on galvanized finishes on poles or other equipment.

Item 1304 Utilities, Permits and Regulations

1304.01 Utilities. Contact the Ohio Utility Protection Service (OUPS), and comply with all OUPS regulations before excavating. Regardless of surface markings for underground utilities, exercise extreme caution in all areas where underground activities are known to exist.

Consult and cooperate with Duke Energy and the Cincinnati Bell Telephone Company in order to provide attachments to each company's respective poles.

Comply with the National Electrical Safety Code Standards for Utility Line clearances on poles and maintain the following clearances:

Utility	Minimum Clearance	To
Telephone, Telecommunications and/or Cable TV	40 inches (1 meter) Below	Proposed 120/240 volt traffic signal and/or street (low voltage) lighting cable
	12 inches (305 mm) Below	Proposed low voltage CTCS tri-cable
Duke Energy 120/240 volt Secondary System	16 inches (406 mm) Above	Proposed 120/240 volt traffic signal and/or street lighting equipment
	40 inches (1 meter) Below	Proposed low voltage CTCS tri-cable
Duke Energy Primary System	6 feet (1.8 meters) Above	Proposed 120/240 volt traffic signal and/or lighting cable and equipment

Maintain a minimum clearance of 27 feet (8.23 m) between the cable and the tracks, where installing cable over railroad tracks. Guy or tether traffic signals and signs installed on spans crossing at railroads with additional messenger cable to prevent equipment from swaying within 12 feet (3.7 m) of the track rail. Maintain a ten-foot (3.05 m) "working" clearance at all times around Duke Energy's primary power system. Notify Duke Energy and the Engineer before working within the ten-foot (3.05 m) zone to ensure proper protection of high voltage cables.

1304.02 Permits. Comply and obtain permits specified in 107.02.

Where Contracts are exclusively for the installation of traffic signal and/or street lighting equipment and bids are let through the City's Purchasing Department, the City may provide marked prints, which indicate existing utilities. The Contractor may use such drawings for the purposes of expediting the permit process.

1304.03 Regulations. Perform all work in accordance with the laws, codes and regulations established by the City of Cincinnati.

Conform to the latest edition of the National Electrical Code and the National Electrical Safety Code, in addition to local codes.

1305 Coordination

Do not remove any operating traffic signal or other equipment from service without seven days prior notification to the Engineer. To resolve any problems that may arise, the Contractor's supervisor of construction must consult with the Engineer before and during construction.

Provide thirty days advance written notice to both the Engineer and the City Traffic Engineer on devices specified to be furnished by the City of Cincinnati for Contractor's installation. (See Item 1308.)

Within seven days after procuring equipment for the City, perform installation and operation of controllers. At its discretion, the City may withhold the furnishing of control equipment to the Contractor for any locations that are not complete and ready to operate or for which catalog cuts have not been approved.

Item 1306 Working Plans

Submit to the Engineer and the City Traffic Engineer for review and approval, four sets of drawings, catalog cuts, specifications, brochures, data sheets, wiring drawings, etc., of apparatus and equipment the Contractor proposes to furnish, and allow thirty (30) days for the Engineer and the City Traffic Engineer to review and comment. Show clearly on all submitted documents the design, quality, dimensions, and other such information as may be necessary for a proper evaluation of the items submitted. On all submitted documents, identify the specific project number, name and year with the bid item reference number to which the apparatus or equipment applies. If more than one catalog number or type is listed on a sheet, indicate the item intended to be furnished by underlining, circling, or otherwise marking.

The City will reject any items failing to comply with specification requirements. Do not purchase or install any of the items until receiving written approval from the Engineer. The Engineer's approval of working plans does not relieve the Contractor of responsibility for erroneous or inconsistent dimensions, notations, omissions or other errors, or the proper functioning of the completed installation. After the Engineer approves, such plans are considered supplemental, but in no sense as a substitute for the original plans.

Item 1307 Standard Drawings

Standard Detail Drawings, showing accepted installation practices and fabrication requirements, are available for download at <http://www.cincinnati-oh.gov/dote/manuals->

permits-supplements/ or are available in booklet form at the Division of Traffic Engineering, 801 Plum Street, Cincinnati, Ohio 45202.

Conform to these standard details where such details are not provided on the plans on all equipment and installations the Contractor furnishes.

1308 Equipment Furnished by the City

Provide all labor, materials and equipment for the complete installation of street lighting circuits and/or traffic control systems in accordance with the plans, details and specifications, except equipment specified as "**Installation only**" or "**Item 1308.01 Equipment to be Furnished by the City.**"

Where the Contract specifies any equipment as **installation only** or **furnished under Item 1308.01**, the City will furnish such equipment requiring Contractor assembly and installation. The City will make payment as indicated in Item 1308.01. Furnish all other hardware, material and incidentals necessary to provide the assembly complete and ready to install.

Depending on the extent and nature of the Contract Work, the City may elect to require the Contractor to furnish all equipment or may provide some or most of the equipment to the Contractor.

The following guidelines generally apply; however, they may be modified depending on the Contract and availability of City-owned equipment:

- A.** Where Contracts are based on unit price bids, the City will furnish only that equipment specified in the Contract bid item as **Installation only**.
- B.** Where traffic signal and/or street lighting installations are bid on a lump sum basis, the City will furnish all equipment as listed under Item 1308.01.

This Contract includes complete specifications for all equipment regardless of whether the City or Contractor furnishes same.

1308.01 Equipment Furnished by the City. Where the Contract specifies that the City will furnish equipment under Item 1308.01, the Contractor will provide some or all of the following equipment and accessories:

- A.** Steel anchor base and/or embedded base poles and posts, including lighting bracket arms, anchor bolts and nuts.
- B.** Wood poles.
- C.** Vehicular and lane use traffic signal heads. Assemble the signal and furnish all other hardware and materials to provide the signal head complete and ready for installation. Furnish all signals with lamps.

- D.** Pedestrian signal heads, including lamps.
- E.** Illuminated signs, including lamps and plastic face.
- F.** Traffic signal controllers, complete with cabinet and with all internal timings setup. Install, and furnish all hardware and incidentals, and connect all signals, un-energized interconnect and power cables.
- G.** Detector amplifiers and video detection equipment.
- H.** Island lights including fixture, globe and lamp, not including hardware for mounting to the post.

NOTE: Furnish and install all mounting or hanging hardware and incidentals to complete the installation.

This item may include other equipment not indicated herein. Provisions of the Contract bid proposal would specify such equipment.

The City will furnish the equipment to the Contractor at the Traffic Services Bureau's Storeroom at 3300 Colerain Avenue– Valley View, Cincinnati, Ohio 45225, and will equip the Contractor only with those accessories this item indicates.

The Contractor loads all equipment into its own vehicles. Payment for hauling and loading equipment is incidental to the item.

Be responsible for all equipment furnished by the City.

In addition to the 30-day advanced written notice, provide an additional 5-day oral or written notice as a reminder prior to picking up equipment. This is included in the 30-day notice.

1309 Installation Practices

1309.01 Lateral Roadway - Structure Clearance. Maintain a minimum of two feet (610 mm) clearance between face of curb and face of pole, pedestal, post, cabinet or equipment attached thereto.

1309.02 Equipment Installation Practices. Install all traffic control devices on a span wire and/or a mast arm(s) for any approach with a level appearance of the lowest part of all the equipment facing the approach, and maintain a minimum clearance of 17 feet (5.18 m) to grade or as plans and specifications specify.

1309.03 Signal and Sign Adjustment. Adjust and perform minor repositioning of signs and/or signals as directed by the City Traffic Engineer. Payment includes cost of the installation of the equipment.

Item 1310 Definitions

Specified. Wherever "specified" is used herein, it means "specified" in the invitation to bid and/or order to Contract.

Signal Section or Optical Unit. That part of a traffic signal consisting of a housing with a lens, reflector and lamp for displaying a signal color.

Signal Face. The assembly of signal sections used to display complete signal indications to one approach of traffic.

Signal Head. An assembly of one or more signal faces, each oriented to an approach of traffic, and all attached to one mounting.

Signal Indication. The illumination of a traffic signal lens (or two lenses concurrently when required) in a signal face for an approach of traffic.

Beacon. A traffic signal consisting of one section and used for flashing operation.

Optically Programmed Signal. Signal head containing optical units projecting an indication, which may be selectively veiled so as to be visible only within desired boundaries.

Sag. The amount of deflection at the lowest point of span wire used for the mounting of signal heads.

Detector. A device used to register the passage or presence of vehicles or pedestrians.

Pedestrian Pushbutton. A detector used at crosswalks for the purpose of registering pedestrian calls to a traffic control unit.

Loop. One or more turns of pavement-embedded insulated wire used to establish a zone of influence for the detection of vehicles.

Loop Detector Amplifier. A device for amplifying the signal generated by the passage or presence of a vehicle over a loop.

City Traffic Engineer. The City Traffic Engineer of the City of Cincinnati or his or her duly authorized representative. Where the Contract is by and under control of the Traffic Engineering Division, the "Engineer" refers to the City Traffic Engineer.

1311 Inspections

1311.01 Responsibilities. In addition to the provisions of Item 105.10, responsibilities are as follows:

- A.** The Engineer approves all trenched conduit before the Contractor backfills and completes encasement.
- B.** The Engineer approves all pullbox installations before backfill.
- C.** The Engineer approves all foundations for anchor base poles and posts, complete with conduit, anchor bolts and rebar cages intact, prior to concrete pour.
- D.** The Engineer inspects and approves all locations the Contractor stakes prior to any excavations.

1312 Electric Power Service

1312.01 Power Source. Obtain electrical power from Duke Energy, Cincinnati, Ohio. Obtain the local power service where plans specify at the designated service pole (SP). Consult and cooperate with Traffic Engineering and Duke Energy to provide service.

Traffic Engineering will authorize the final service connection application to Duke Energy after inspection. Traffic Engineering will make such inspection within two full working days of Contractor's request.

1312.02 Electrical Energy. Electric power required is a 60 Hertz, single phase 120 volts - two wire system for traffic control equipment, and, unless otherwise specified, a 240 volt - three wire system for street lighting equipment.

NOTE: Duke Energy crews will make electrical connections to any Duke Energy power source. The Contractor must strip the neutral cable of insulation up to the point of entry into a conduit riser or pole.

1312.03 Power Service. Power service consists of equipment installed, as detailed, to provide pole attached raceways and disconnect switch for use with power cable routed from the service pole to the lighting circuit and/or the traffic signal controller.

Raceways include the specified weatherhead and conduit risers, with all necessary hardware. Terminate conduit risers at the disconnect switch enclosure. From the switch enclosure, connect with underground conduit or conduits to the specified pole or pullbox. Where using a steel pole, Contractor may use the interior of the pole instead of external conduit for the power cable raceway.

Meet the requirements of 1321.06 for materials and installation of the weatherhead and conduit risers. Furnish sizes as shown on the plans and details.

Conform to Item 1321.04 for steel conduit requirements. Conform to Item 1321.04 for PVC Type II conduit requirements.

Disconnect switch means a safety switch or street lighting controller per Item 1324.03 as the plans specify. When mounted on a pole, mount the switch so that the bottom of the disconnect switch is a minimum of eight feet (2.44 m) above grade, unless otherwise noted on the plans.

Install two 3/8 inch (9.5 mm) drain holes in the bottom of the switch enclosure.

Ground all non-current carrying metal equipment enclosures to the pole ground cable, or in the case of steel poles, the pole ground nut as shown on the details and as Item 1320.01 indicates. Verify that the pole ground cable is continuous to ground.

Where electric power is indicated on a pole remote from the pole housing the disconnect switch, furnish and install an overhead service cable per Item 1323.01 connecting the two poles, including all accessories and hardware.

Power service may be specified as a single pay item which includes all items listed under section 1312.03, or items required to provide power service may be individually specified bid items.

Furnish and install the weatherhead and conduit risers disconnect switch (1324.03), underground conduit, power cable, service cable (where the Contract specifies) and all hardware and connections.

1312.04 Service Pole. Where the Contract specifies, furnish and install a wood pole of the correct size in conformance with the requirements of Item 1318.04. This item of work includes furnishing and installing a ground wire secured on the pole as plans indicate, and providing and installing a ground rod, all in accordance with Item 1320.02.

1312.05 Basis of Payment. The City will pay for accepted quantities at the Contract price as follows:

Item	Unit	Description
1312	Each	Power service
1312	Each	Service pole

1313 Testing

1313.01 General. Perform testing in conformance with the requirements of Item 625.19, with the following exceptions:

A. Cable Insulation Tests for Traffic Signal Equipment. Measure the insulation resistance for each conductor (including spares) of cable or wire terminating at the controller

cabinet. The City requires insulation resistance exceeding ten megohms prior to acceptance. Measure insulation resistance for the wire of roadway loops before and after embedding the wire with sealant in slots. Furnish test results listing the resistance readings for each conductor.

Connect all cabinet wiring in accordance with the wiring diagram after completion of the cable insulation. Demonstrate, to the satisfaction of the Engineer, that all circuits are continuous and operating correctly with freedom from shorts, crosses and unintentional grounds.

B. Performance Test for Traffic Signal Equipment. Prior to acceptance, operate the traffic control system continuously for ten consecutive days without interruption from malfunctions or failures.

At new signal locations on facilities opened to traffic, place the signal on flashing operation for a minimum period of five days prior to the testing and subsequent operation of the signal unless directed otherwise by the Engineer.

During the period of testing, if vehicle or pedestrian traffic is in current use, maintain the equipment except for the traffic controller. The City of Cincinnati maintains the traffic controller. In the event of any malfunction of the equipment the Contractor installs, the City will make repairs on an emergency basis. The City will charge the Contractor the cost of repair based on actual labor cost plus 50 percent, actual material cost plus ten percent for handling, established cost per hour of the trucks and equipment required in addition to approximately 50 percent of total cost to cover overhead (administration of billing and accounting).

During the test period at intersections where pedestrians and vehicles are not using the traffic signal equipment the Contractor installs, correct malfunctions of the installation with the exception of failure of the traffic controller.

Immediately replace any failed lamp; lamp replacement does not require a restart of the test. Furnish test results including the method and date of correction of each fault, and the beginning and end of the ten-day test.

C. Performance Test for Lighting Equipment. Prior to acceptance, operate all new lighting equipment continuously for a period of five days (120 hours). Immediately replace any failed equipment or components. Replacing any failed equipment or components does not constitute a restart of the test. However, should the number of failures be substantial in the judgment of the Engineer, the test may extend until such time as the Engineer determines that the system is satisfactory.

1313.02 Acceptance. Upon acceptance of the project, transfer to the City all Manufacturers' guarantees or warranties covering installed electrical or mechanical equipment. For electronic control type and special equipment, furnish three copies of wiring diagrams, a service manual and instructions on installation and maintenance for each different type, model or system of equipment used on the project.

Notify the City Traffic Engineer or his or her authorized representatives, and meet with them on the site when the new traffic signals are turned on color. Provide records indicating the time and date of both the start of the flashing operation and full color operation.

1313.03 Testing and Acceptance of Controller Installations. Provide certification of all controller installations for all locations where the Contractor sets up, tests and installs traffic signal controllers prior to final release.

Perform final test consisting of 30 minutes of operation without failure of the controller or incorrect color sequence operation before acceptance. Should any malfunction occur as the result of poor workmanship, make all necessary repairs on site.

Should the controller malfunction within 60 days of the final test due to poor workmanship on the part of the Contractor, the City will bill repairs for such work to the Contractor. The City will charge the Contractor the cost of the repair based on City charges as outlined in paragraph 1313.01.B.

1314 Maintenance of Traffic and Systems

1314.01 Maintenance of Traffic. In addition to the requirements of Item 614 "Maintaining Traffic" in the ODOT CMS and the modifications thereto in this Supplement, the following apply:

Provide adequate and safe traffic control at locations under this Contract utilizing advance warning devices, police, flagmen, labor and materials consistent with the Ohio Manual of Uniform Traffic Control Devices and which the City approves.

Submit a plan or plans for the maintenance of traffic to the City. Such a plan or plans must meet with the approval of the Division of Traffic Engineering. Submit the plan at least five days in advance of any Contract work at the location(s) involved.

Provide police in assistance of traffic maintenance and control during the periods where the traffic signals may have to be turned out and at all locations the City Traffic Engineer deems necessary.

Disable no more than one traffic signal location for the purpose of Contract work at any time where more than one of the specified locations are on the adjoining major street and are adjacent to one another, unless the City Traffic Engineer approves in writing. Do not work at any location during the hours of 7:00 - 9:00 A.M. and 4:00 - 6:00 P.M., Monday through Friday, or as the Contract bid proposal provision indicates.

If for any reason the Contractor is unable to comply with the provisions of his Contract, the Engineer will impose special requirements as may be necessary for the safety and convenience of the public. Special requirements may include, but will not be limited to:

- A.** Services of an off-duty Cincinnati Police Officer(s)
- B.** Work on a continuing basis

C. Temporary restoration or plating.

1314.02 Maintenance of Existing Street Lighting Circuits. Maintain the existing street lighting system in operation until the City tests and accepts the new circuit(s). Maintain the existing circuits using temporary wiring or by scheduling installation of new equipment so as not to disturb the existing circuit.

The Contractor is responsible for any damage to any of the street lighting components due to the Contractor's operations.

The City of Cincinnati is responsible for normal maintenance of the street light system(s), including lamp replacement, maintenance of the control equipment and repairs required due to outages caused by circumstances other than the Contractor's operations.

Should construction of the new street lighting circuit necessitate removal or de-energization of all or part of the existing street lighting circuit, maintain lighting on one side of the roadway or seek approval to provide temporary lighting during construction. Do not leave the roadway purposely unlit under any circumstances.

Obtain approval of the City Traffic Engineer for any proposed method for maintaining the lighting system.

1314.03 Maintenance of Existing Traffic Signal Installations. Keep the existing traffic signal in operation until the new signal is operational. Reinstall existing items to be incorporated into the new traffic sign after completing all other new work which can be done prior to the relocation work. Cooperate with the Engineer and make all temporary signal adjustments as the Engineer directs.

Maintain and keep operational the existing traffic signal until all other new equipment had been installed and is functional. Work will include any modifications to existing or temporary traffic signal installations as required by changes in construction or operational conditions in the project area throughout the entire contract period. This will include relocations, removals, covering or uncovering of traffic/pedestrian signals and illuminated/reflectorized signs and other traffic signal equipment, and the installation of temporary poles or temporary pole guys to satisfy safety and operational conditions throughout the project. This work will be performed as directed by the Engineer. The Contractor is responsible for any damage to any of the traffic signal components required to be handled during relocation of poles and modifications to the signal system. The Contractor is responsible for normal maintenance of the traffic signal, including lamp replacement and repairs required due to outages caused by circumstances other than the Contractor's operations. The City of Cincinnati is responsible the maintenance of the controller equipment.

Where proposed new equipment blocks or obscures the line of sight of existing equipment, or where new equipment is proposed in the same location as existing equipment, temporarily adjust existing or new signals and signs. New traffic signals and signs which were temporarily adjusted, must be re-positioned in the proposed locations as indicated in the plans after existing equipment is removed.

The City Traffic Engineer must approve all adjustments.

Schedule the construction of the traffic signal installations to maintain the interconnect system throughout the Contract. Use existing interconnect cable, temporary cable, or newly installed interconnect cable to maintain the interconnect system.

At installations where interconnect cable does not exist, install the specified new interconnect cable system prior to completing and operating new or reconstructed traffic signal systems, or provide, subject to the Engineer's prior approval, an equivalent approved means of maintaining coordinated signal operation at all times.

1314.04 Performance. If in the opinion of the City Traffic Engineer, the Contractor does not provide proper maintenance of traffic facilities and proper provisions for traffic control, the City may take the necessary steps to place them in proper condition, and bill the cost of all labor and materials by City personnel to the Contractor.

1314.05 Basis of Payment.

A. The City will make payment for Item 1314.01 "Maintenance of Traffic" in accordance with and under Item 614. Include all labor, materials, temporary signs, cones, barrels, barricades, flashing arrow barricades, flagmen, police and all control devices, equipment and incidentals.

B. The City will make payment for Items 1314.02 and 1314.03 at the unit price bid per each street lighting circuit and maintenance of traffic signal location, including all labor, material, tools, equipment and incidentals.

Item	Unit	Description
614	Lump Sum	Maintenance of Traffic
1314	Each	Maintenance of Existing Street Lighting Circuit
1314	Each	Maintenance of Existing Traffic Signal Location

1315 Temporary Systems

1315.01 Temporary Street Lighting. Provide temporary lighting where specified and where the existing lighting system is in the way of construction and Contractor must remove prior to the installation of the proposed new lighting circuit(s).

Submit a plan for approval to the City Traffic Engineer indicating the methods, materials and equipment to be used.

Temporary lighting is to provide a minimum of one foot candle (10 lx) maintained, unless otherwise noted in the Contract Documents.

Install temporary lighting on existing or new wood or steel poles. Conform to the National Electrical Code and the National Electrical Safety Code, with no exposed wiring or material, which could be hazardous to pedestrians or motorists in the area. Mount luminaires with sufficient mounting height in order to reduce glare to a minimum.

Maintain and assume responsibility for the temporary lighting circuit(s) until the proposed new lighting circuit is operational. Respond to and correct any outages within 24 hours of notification.

1315.02 Temporary Traffic Signal Installation. Where the Contract specifies, install a "temporary" signal system(s) as a complete installation at a unit price bid per each intersection.

Install all equipment and materials the plans show and detail, and furnish all items except those specified "installation only" or as Item 1308.01 specifies. Furnish materials and equipment in accordance with all of the provisions and specifications for permanent signal systems as indicated herein.

1315.03 Method of Measurement. The City will measure temporary street lighting as a complete unit in place, including testing and accepting all wiring, luminaires, poles, brackets, conduits, risers, control equipment and all materials as necessary to provide an operational and satisfactory system.

The City will measure temporary traffic signal installations as complete units in place, including all testing and accepting all signals, signs, detectors, poles, wiring and materials necessary to provide a complete and operational system.

1315.04 Basis of Payment. Include the cost of electrical energy and all labor, materials, equipment and incidentals necessary to install, maintain and subsequently remove the temporary system(s).

Item	Unit	Description
1315	Lump Sum	Temporary Street Lighting
1315	Each	Temporary Traffic Signal Installation by Location

1316 Removal of Existing Equipment

1316.01 Removal of Existing Street Lighting Equipment. Remove existing poles, brackets or other arms, fixtures, foundations, pull boxes, cable equipment, control equipment and materials which are not slated for reuse in new installations in accordance with Item 202. Unless the Contract specifies otherwise, abandon conduit and underground cable. Deliver removed reusable equipment to the Traffic Services Bureau, 3300 Colerain Avenue, Cincinnati, Ohio 45225.

Where the Contract specifies partial removal of foundations, remove foundations including anchor bolts to a minimum of one foot (305 mm) below proposed finished grade, unless otherwise specified in the Contract Documents. Finish level to existing pullbox, paved area or other as specified with Class QC1 concrete and low strength material meeting the requirements of 613. Fill exposed conduit entries with Class QC1 concrete. Restore concrete walks or driveways from joint to joint.

1316.02 Removal of Existing Traffic Signal Installation, by Location. In accordance with Item 202, include the removal of the signal heads, controller, detectors, strain poles, pole foundations, cables, messenger wires, conduit, pullboxes, and all other portions of the existing traffic signal not slated for reuse in the new installation.

With the exception of items to be relocated and incorporated into the new installations or whose removal is otherwise necessary to permit the installation of the new signal equipment, remove no items until the new installation is in full operation unless the Engineer directs otherwise.

Remove and reinstall reusable items as part of the new signal installation under items further noted as "relocated".

All other items, except those noted under the bid proposal's provisions as removed and returned to the City of Cincinnati, become the property of the Contractor. Remove and lawfully dispose of those items.

1316.03 Removal of Existing Interconnecting Cable. Where new interconnecting cable replaces existing cable, payments for removal of existing cable (including existing messenger cable, sectionalizers and hardware) are incidental to the installation of new cable. The estimated linear feet of cable to be removed are indicated in the quantities.

1316.04 Removal of Existing Equipment, by Item. Where specified by item, remove the equipment indicated. Return reusable equipment to the City's Traffic Services Bureau, 3300 Colerain Avenue Building, Cincinnati, Ohio 45225. Dispose of all unusable material(s) lawfully offsite.

Include all mounting hardware, incidentals and accessories supporting or part of the equipment, which the Contract does not specify to be retained in equipment to be removed. Included with this item of work is the required modification of existing hardware, wiring or rewiring to maintain the existing equipment the Contract does not specify to be removed, intact and operational.

Where removing equipment as part of an electrical assembly, also remove all existing debris and dirt.

1316.05 Removal of Existing Poles. Remove all embedded poles the Contract does not specify to be used, to a minimum depth of one foot (305 mm) below existing grade. Include foundation removal in all anchor base poles the Contract specifies for removal. Backfill all excavated foundation holes and openings with low-strength material meeting the requirements of 613.

Return all salvageable and reusable anchor base and embedded base poles to the City Traffic Engineering Division's pole yard.

Keep adequate walking areas for pedestrians clear of equipment, materials, supplies and excavated materials at all times.

Move any excavated material obstructing any portion of the sidewalk or street area at the end of the working day, so as not to obstruct the sidewalk or street area.

Remove excavated materials from sidewalk areas, and dispose of lawfully off site.

Neatly restore sidewalks, driveways, and sodded areas to the satisfaction of the City, in accordance with Item 1334. Restore concrete walks and driveways from joint to joint.

1316.06 Method of Measurement. The City will measure removal of existing equipment as a complete unit, by circuit, location, or by item as the Contract specifies, including all excavations, restorations, backfilling, disconnections, removal of hardware and debris and incidentals necessary to remove each item complete and clear of adjacent equipment specified to be retained.

1316.07 Basis of Payment. Payment is full compensation for furnishing all labor, materials, equipment and incidentals required to completely remove the item or equipment specified, including restoration. The City will pay for accepted quantities at the Contract price as follows:

Item	Unit	Description
1316	Lump Sum	Removal of Existing Street Lighting Equipment
1316	Each	Removal of Existing Traffic Signal Installation by Location
1316	Each	Removal of Existing Equipment, by Item
1316	Each	Removal of Existing Poles

Item 1317 Painting

Paint traffic signal and street lighting equipment, in accordance with 514 where applicable, except as modified herein.

Furnish all labor and material to complete this item of work. Include payment with the item painted.

Where the Contract specifies, use a zinc rich dust primer. Use alkyd resin exterior enamel finish coat.

Spot prime, prime coat and finish coat galvanized surfaces, poles, exposed conduit, brackets, drop pipes, and cabinets.

Spot prime where cuts are made into steel material with soya-alkyd primer with at least 60 percent pigment by weight being zinc dust, "Zinc It" (cold galvanizing coating) by CRC Chemical Company, or approved equal.

Paint both inside and outside of wood tree mouldings with two coats of hot linseed oil. Polycarbonate housings need not be painted.

Apply paint in the field only when the ambient temperature is above 50° F (10° C), and the surface to be painted is dry.

The following are approved finish colors, unless otherwise specified:

Item to be Painted	Finish Color
Traffic Signal Poles	Light Gray
MPL/T – MOL/T Poles	Semi-Gloss Black, Federal Color Number 27038
Street Lighting Poles	Black or Green for Parkways Black or Green as Indicated for Parks Gray in all other areas
Vehicle and Lane Use Signal Heads	Black on backs Black Inside and Outside on Visors Yellow on Front and all Other Areas
Pedestrian Signal Heads	Black on visors Black UNO
Pedestrian Pushbutton Housings	Yellow
Internally Illuminated Signs	Black UNO

Colors of paint must be in accordance with Federal Standard No. 595. Color Nos., as follows:

Color Name	Federal Color Number
Pole Gray	16251
Pole Green	14062
Highway Yellow	13507
Highway Green	14109
Gloss Black	17038
Gloss White	17875

Beige	20372
Semi-Gloss Black	27038
Semi-Gloss White	27875
Lusterless Black	37038
Lusterless White	37875
Mallard Green	Sherwin Williams #SW2392

Item 1318 Poles and Supports

1318.01 Steel Poles.

A. General. This item includes the fabrication and installation of steel lighting poles with bracket arms, signal strain poles, signal arm support poles and combination lighting and signal poles and others as the Contract specifies.

B. Shafts. Construct all lighting, signal poles and mast arms of tapered tubes of either a true continuous taper or of a sectional type consisting of straight sections with a tapered effect using reducers or by swaging. Provide circular tubes. Measurements of circular tube diameter at a specific point along the longitudinal cannot vary by more than 3/16 inch (5 mm). Taper cannot exceed 0.10 inch (2.5 mm) or more than 0.14 inch per foot (11.7 mm/m). Do not include the portion of embedded base poles below groundline in determining taper.

Conform to plan specifications and details for pole and arm length, diameter, gauge, anchor bolt circle diameter, and anchor bolt size.

Meet the AASHTO "Specifications for the Design and Construction of Structural Supports for Highway Signs" for steel material and have minimum yield strength of 55,000 psi (380,000 kPa). Provide sectional type poles open-hearth, grade B, black steel pipe per ASTM A-53.

Demonstrate support designs not specifically detailed on the plans to the satisfaction of the City Traffic Engineer, as structurally equivalent to the design the Contract specifies.

Poles and mast arms of the true continuous taper type may be fabricated in two portions joined by overlapping of sections (field joint) with the overlap being at least 1-1/2 diameters as determined by the largest diameter of the outer portion. Assemble sections with a 5/8 inch (16 mm) minimum stainless steel hex head through-bolt. Do not use field joints for poles and arms less than 38 feet (11.6 m) long.

Contractor may use one longitudinal, automatically electrically welded seam on circular poles. Welded seams are to be neat and uniform in appearance and have a thickness not less than the base material and a bead height not exceeding 1/16 inch (1.6 mm). The wall thickness at each pole or arm cross section should be of uniform thickness, except at weld beads. Do not use transverse seams or welds on true continuous taper type poles or arms. Welds must conform to Item 513.21.

Furnish embedded type poles with ground collars at least 3/16 inch (5 mm) thick for lighting poles and 3/8 inch (10 mm) thick for signal strain poles, sleeved over and welded to the pole. Locate the collar on the pole at the point where the pole would protrude above the groundline as the details indicate.

C. Anchor Bases and Bolts. Fit anchor bases for poles with a welded-on cast or plate steel base designed to mount on an anchor bolt foundation as shown. Include the furnishing of anchor bolts, nuts, washers and shims. Anchor base steel castings to meet the requirements of Item 711.07. Furnish steel plate bases that meet the requirements of Item 711.01. Weld shafts to base both inside and outside, using continuous welds.

Provide square bases with 4 bolt bolt-circles.

Galvanize anchor bolts in accordance with ASTM A153, with galvanizing extending at least two inches (50 mm) beyond the threads. Furnish individual anchor bolt covers, or cover bases for poles erected in sidewalks, traffic islands, curbed areas, and seeded areas of urban character, or when the Engineer directs. Use "L" shaped anchor bolts.

D. Loading. Design completed assembled poles to carry the loading as the detail specifies, or on the plan specifying a non-standard size pole, without exceeding the rated deflection, cracking, breaking, deforming in permanent set or failing in any way. Include torsional as well as horizontal and vertical loads and ice and wind loading.

The City Traffic Engineer may require approval of poles furnished in accordance with Item 725 tests.

Take the load at yield point of any poles at 18 inches (500 mm) from its top.

E. Mast Arms. The Contract requires quantity and orientation of Mast arms. Provide poles and mast with attachment plates and gussets as the plans detail. Assemble with high-strength bolts as shown, with the connection developing the full moment-resisting capability of the arm. Butt diameter of mast arms must be smaller than the diameter of the pole at the point of attachment.

F. Slip Fitter Arm. Where specified, provide a two foot long (610 mm) by two-inch (51 mm) schedule 40 galvanized steel pipe for mounting luminaires. Weld a 2-3/8 inch (60 mm) I.D. 1/2 coupling, threaded inside, to the pole for attachment of arm.

G. Bracket Arms. Conform street lighting bracket arms, including pole and bracket plates, as shown on the details. Fabricate arms from two inch (51 mm) nominal size galvanized pipe.

Pipe strength must conform to ASTM Designation A53 (ASA-B36.1) or schedule 40 in accordance with ASTM Designation A120 (ASA-B36.20).

Design mast arms using upsweep construction as shown on the details or as the Contract otherwise specifies. The bracket arm assembly, including all connections, must be of sufficient strength to transfer all loads up to the yield strength of the pole shaft without undue

deflection. Design arm must support a (minimum) 75 pound (34 kg) luminaire having a projected area of 3.3 square feet (0.3 m²). Provide a minimum eight-inch (200 mm) length at the end of each arm to receive a slipfitter, mounted luminaire.

Construct bracket arms eight feet (2.5 m) or longer of an upper and lower member securely joined by means of a vertical strut or struts.

H. Transformer Bases. Make steel transformer bases from steel conforming to ASTM A36.

Meet the dimensional requirements of the plans and approved shop drawings for aluminum transformer bases designated on the plans by Styles AT-C, and AT-X. Bases are to transmit the design dead, live, ice and wind loads of the light pole to be mounted on it to the foundation without failure or permanent deformation. Comply with the frangibility requirements the AASHTO "Standard Specifications for Structural Supports for Highway Signs, Luminaires and Traffic Signals" specifies, except that in lieu of the requirements of Section 1.7.2-Design, breakaway supports to carry loads as Section 2 provides and to cause a change in vehicular momentum no greater than 1,100 pound-seconds (500 kg-seconds) when impacted by a 2,250 pound (1,000 kg) vehicle traveling at any speed within a range of 20 to 60 miles (30 to 100 km) per hour.

Permanently mark aluminum transformer bases for exterior identification. Fabricate doors so that they will fit flush with the face of the base, and attach permanently by means of a top-mounted, continuous, stainless steel hinge. Latch doors by means of a tamperproof, quarter-turn latch.

Construct base as a breakaway base using permanent mold casting per ASTM B108. Heat-treat base to 356-T55 to meet Federal Highway Administration requirements. Furnish four heavy-duty hex head bolts and nuts conforming to ASTM A307 and galvanized in accordance with ASTM A153.

Paint the bottom of the steel pole anchor base and the top of the aluminum transformer base with a heavy film of zinc-rich paint (Federal Spec. TT-P-64, Type II) where mounting steel poles on aluminum bases.

I. Accessories. Include a handhole near the base of each pole oriented as shown. Weld a steel reinforcing frame to each handhole fit with a cover plate fastened by stainless steel screws. Provide a grounding lug opposite handhole on inside wall of pole as shown on the details. Include a wire support J-hook welded near the top and a removable pole cap for each pole. Design poles and arms so their interiors may be used for concealed wiring. Include grommeted wire outlets for signal heads in each mast arm. Furnish hanger clamps with clevises on the mast arms for the signal heads and signs as required. Include a removable end cap for each mast arm.

Provide a handhole located opposite the mast arm flange with an additional J-hook located a short distance above for signal poles combining provisions for roadway lighting. Include bracket arm pole plates.

Furnish pedestrian pushbutton access holes and blind half-couplings for cable, pedestrian signal heads, etc., as plans require.

J. Welding. Make all welds continuous weld as Item 732 requires. Develop full strength of pole by all structural welds. Welds attaching modifications (all others are structural) must be sufficient to carry the load with a good factor of safety. The welding process must not reduce the strength of the pole adjacent to welds.

K. Galvanizing. Hot dip galvanize all parts, inside and outside, of all steel components, fittings and fasteners after performing cutting, welding, drilling, boring, etc. Clean threads after galvanizing. Galvanize in accordance with the following ASTM Designation Nos.:

1. Poles, Seamless Steel Pipe- --- A123
2. Iron and Steel Hardware and Fasteners- --- A153
3. Bracket Arms- --- A53

L. Installation. Cure new concrete anchor base foundations for at least seven days before setting anchor base poles. Rake steel poles as details specify for the pole size against the resultant strain produced by the proposed messenger cables, mast arm and/or bracket arm.

Do not load steel anchor base or embed base poles by attaching messenger cables and/or mast arm until all the concrete cures for a period of at least 14 days.

Use lesser times for installing and loading of poles in accordance with 511.14, if beam test specimens exceed strength requirements.

After attaching all proposed equipment and materials that will be supported by an anchor base pole, adjust the leveling nuts so that the center of the top of the pole is directly above the center of its base.

Inspect galvanized poles for defects in galvanized surfaces after erection. Spot prime minor defects or scratches and paint the entire pole in accordance with Item 1317.

Remove burrs, projections and sharp edges, which could damage cable from cable entrances and raceways in the poles and arms.

M. City Pole Design Number and Definitions. See Table 1318.01 for chart of City pole design number showing gauge, base type, lighting arm length, lighting arm type, lighting fixture mounting height and gusset plates for signal arm attachment.

Table 1318.01 – City Pole Design Number Key

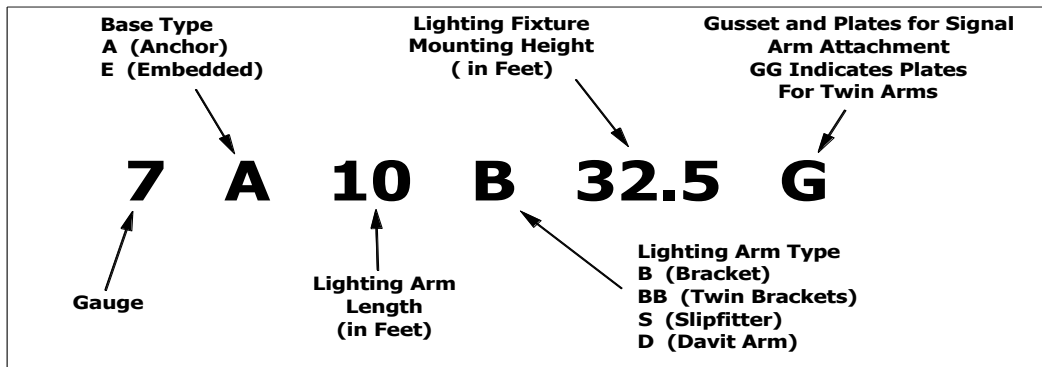

1. For signal strain poles: First two digits indicate transverse load in hundreds of pounds. The last three digits indicate deflection in inches per hundred pounds. Refer to Standard Drawing ES-1.

2. For lighting, combination lighting and signal arm poles, refer to Standard Drawing ES-3B.

Permanently attach City pole design numbers to the bottom of the pole on a metal tag.

1318.02 Pedestals. Fabricate pedestals for the support of traffic control and/or Island Lighting equipment of nominal three or four inch (75 or 100 mm) diameter seamless schedule 40 steel pipe and length as Contract specifies, with parts hot dipped galvanized in accordance with ASTM A123. Design pedestals to mount on an anchor bolt foundation as plans show.

Thread pedestals into an anchor base prior to mounting. Spot prime the threaded portions of the pedestal and base with soya-alkyd primer with at least 60 percent pigment by weight being zinc dust, "Zinc It" (cold galvanizing coating) by CRC Chemical Company, or approved equal, prior to assembly.

Provide all pedestals with an approved grounding lug, field drilled and fastened to the inside of the pedestal as details show. Provide all pedestals not requiring a post top attachment with a galvanized pedestal cap. Include the furnishing of anchor bolts with each pedestal.

Specify pedestal diameter. Use four inch (100 mm) diameter pedestals for pedestrian pushbutton posts.

1318.03 Guy Supported Mast Arm with Accessories. Furnish and install mast arms of the length specified to support signals, signs and detectors as plans and details show.

Construct arms of two inch (50 mm) galvanized steel schedule 40 pipe and fasten to the signal pole with spreader arms, guy rods, pole clamps and/or plates, guy support hardware and all fittings as details show.

1318.04 Wood Poles. All wood poles to be from Southern Yellow Pine and meet the requirements of ANSI Standard 05.1 "Specifications and Dimensions for Wood Poles" except as modified herein.

A. Treatment. Season poles and pressure treat in accordance with AWPA Standards C1 and C4 using the full cell process and with any exceptions indicated herein.

B. Conditioning. Accelerate air season (AAS) poles to an average moisture content of 25 percent at 2-1/2 inch (60 mm) depth.

C. Preservative and Results of Treatment. Table 1318.04 lists approved preservatives and the process and results of treatment to meet the requirements in Table 1318.04.

Table 1318.04 – Approved Preservatives, Processes and Results for Treatment

Preservative Code Description	APWA Preservative Standard	APWA Standard for Analysis of Preservative	Results of Treatment		
			Minimum Penetration (% of Sapwood)	Minimum Retention lb per ft ³ (kg per m ³)	Method of Determination
SK Chromated Copper					
Arsenate CCA Type C	P5	A2	90	0.60 (10)	By Assay

E. Determination of Penetration. Determine penetration in accordance with AWPA Standard C4 - Group "B" Poles.

F. Re-Treatment. Contractor may retreat poles failing to meet the minimum requirements of either penetration or retention in accordance with AWPA Standard C1, Paragraph 6 - Re-treatment, with the exception that Contractor must restrict retreatment to one time for any pole.

G. Re-Drying. Re-dry poles treated with a water-borne preservative to an average moisture content not to exceed 27 percent at 2-1/2 inch (64 mm) depth following the full cell pressure-treatment.

H. Marking. Mark poles by burn-branding legibly and permanently on the face and on the butt.

I. Ground Wire. Provide poles with a 1/4 inch (6 mm) brass or No. 2 bare copper solid ground wire. Secure ground wire to the pole with copper staples as plans show. Extend the ground wire the entire length of the pole above grade with at least three feet (914 mm) of slack for connection to a ground rod.

Protect the ground wire up to a minimum of eight feet (2.5 m) above grade as follows:

1. Milling or sawing a 1/4" x 1/4" (6 mm x 6 mm) slot in the face of the pole and inserting and securing the ground wire, or
2. Covering the ground wire with a wood tree molding. Construct molding of seasoned wood or highest grade fir and provide two coats of hot linseed oil prior to installation. Secure the molding to the pole with copper staples.

J. Inspection. The Engineer may inspect all poles at his or her discretion. Poles not meeting the minimum requirements of this specification will be rejected and disposed of at Contractor's cost. Notify the Engineer when poles are ready for shipment to the site so that the Engineer may schedule an inspection.

K. Installation. Excavate for wood poles by auger or hand labor and to the dimensions shown on the details for the pole size specified.

Place a brick or concrete block in the excavated hole prior to insertion of the pole to prevent settlement of the pole.

Construct concrete collars of Class QC1 concrete.

Use excavated material as backfill.

Rake poles installed in the excavated foundation as details show. Cure concrete collars for at least three days prior to loading by the attaching of messenger wire and/or mast arms.

Where plans specify strut guys with the pole, use additional concrete, anchor rod and accessories.

Where plans specify poles to be installed in paved areas, provide a 1/2 inch (13 mm) expansion collar.

1318.05 Pole Guys.

A. General. Furnish and install pole guys by type as shown on the plans and details and as herein specified.

B. Guy Wire. Construct the guy wire of a minimum 5/16 inch (8 mm) (7 No. 10 AWG) copper covered steel messenger wire per ASTM A-460.

C. Strut Guy. Construct anchor rods of steel with thimble eye and guy rod washer and with an ultimate strength of 16,000 lbs. (72,000N) (minimum). Support the guy wire from the pole with two each steel pole struts as shown on the details.

D. Down and Sidewalk Guy. A thimble eyed steel anchor rod with a steel helix screw or deadman anchor.

1. Helix Screw. Construct of six inch (150 mm) diameter (ultimate strength including rod, 23,000 lbs. (100,000 N) minimum).

2. Deadman Provide a minimum four feet (1.2 m) long wood stub post ten to 15 inches, (250 to 380 mm) in diameter. Treat the post and meet the requirements of Item 1318.04 "Wood Poles". Use anchor rod with deadman to bear 16,000 lbs. (72,000 N) ultimate strength (minimum).

Provide a guy wire with an eight foot (~~2.5 m~~) plastic, PVC or No. 18 gauge steel guy guard at grade. Guy guard should be highly visible yellow or if steel have a 1" wide yellow or white reflective tape stripe down the center along the length of the guard.

Where plans specify a sidewalk guy, provide an additional two inch (50 mm) schedule 40 steel pipe to suspend the guy from the pole to provide adequate clearance for pedestrian use of the sidewalk.

E. Head Guy. Support guy wire between poles and attach to poles as shown in the standard drawings.

F. Hardware. Secure guy wires with a three bolt steel suspension clamps rated for 25,000 lb. (120,000 N) cable strain for 1/4 to 3/8 inch (6 to 10 mm) guy wires using 1/2 inch (13 mm) high strength track bolts and served into a five to seven inch (130 to 180 mm) mause. Provide all thimble eyes, through bolts, lag screws, pole plates, fittings, nuts and bolts as details show.

Hot dip galvanize all hardware, anchor rods and screws, struts, guy guards and pipe in accordance with ASTM Specification A-153 and A-53 for pipe.

G. Installation. Install the pole guy prior to the installation of signal equipment on the span and/or mast arm attached to the pole.

Install the anchor by power or hand auguring. Thoroughly tamp loose soil produced by the auguring to maintain maximum tension in the guy.

After installation, tighten the guy wire such that the resulting deflection of the pole due to signal load is corrected and the pole is plumb.

1318.06 Cable Support Assembly. Where plans specify, furnish and install a cable support assembly. Use the cable support assembly with each cable or cable group entering the interior of steel poles by weatherhead or mast arm. Assemble using a cable grip and, when plans require, a length of messenger wire forming a sling including thimbles and split bolt clamps. The support eliminates cable strain at the pole inlet by placement over the J-hook provided within the pole.

Make the cable grip from the proper size and strength for the cable or cable group of the flexible "closed" or "split with rod" type, of stainless steel or tin coated bronze, and equip it with a single "U" eye bale. Construct the smallest cable grip to have a minimum rated breaking strength of 250 pounds (1,000 N).

Make slings for cable supports from three-strand 0.165-inch (4 mm) diameter copper clad or galvanized twisted steel wire with length as plans require. Use groove thimbles to form eyes at each end of the sling to match the wire. Adjust the sling to the proper length with the wire at each thimble and lap and secure with No. 6 split bolt clamps.

1318.07 Method of Measurement. Measure holes, complete with mast and/or bracket arms and pedestals as a complete unit in place including furnishing anchor bolts, which are installed as part of the foundation, and raking and painting.

Measure guy supported mast arms as a unit by length, and erect in place including clamps, guy rods, spreader arms, fittings and hardware.

Measure wood poles as a unit in place including the excavation, concrete, backfilling, raking, ground wire installed, moulding, expansion collar and removing waste and incidentals.

Measure pole guys as a unit by type assembled and installed complete with all hardware and accessories.

Measure cable support assemblies as complete units in place and accepted, including grips, sling wires, thimbles and clamps.

1318.08 Basis of Payment. City will make payment at the Contract unit price bid for each item as the Contract specifies and be full compensation for all labor, materials, tools, equipment and incidentals necessary for each item furnished complete, in place, and accepted.

Item	Unit	Description
1318	Each	Signal strain pole, ___ gauge, ___ inches (base) by ___ feet (length), City Design No. ___
1318	Each	Signal arm pole, ___ gauge, ___ inches (base) x ___ feet (length), with mast arm(s) ___ gauge, ___ inches (base) x ___ feet (length), Design No. ____.
1318	Each	Each Lighting pole, ___ gauge, ___ inches (base) x ___ feet (length) with ___ foot bracket arm, Design No. ____.
1318	Each	Pedestal, ___ inches (diameter) x ___ feet (length).
1318	Each	Guy supported mast arm, ___ feet (length) with accessories.
1318	Each	Wood poles, class ___ foot (length).

1318	Each	Pole guy, ____ type.
1318	Each	Cable support assembly.

Item 1319 Foundations

1319.01 Concrete Foundations.

A. Location. Locate and stake foundations for poles, pedestals and ground mount cabinets at the proper survey station, or dimension reference, and with the proper elevation in accordance with the plans. Where plans provide no locations or dimensions, the City will provide staking.

Check for underground or overhead obstructions during staking and if encountered the Engineer may change the foundation location. After staking, notify the Engineer at least three days before scheduled work so the Engineer may field check the foundation locations for approval. After approval, set the correct location, elevation, attitude (either vertical or with rake) and horizontal orientation for all poles, pedestals and cabinet bases used with the foundations.

B. Excavation. During excavation, keep adequate walking areas for pedestrians clear of equipment, materials, supplies and excavated materials at all times. Move any excavated material obstructing any portion of the sidewalk or street area at the end of the working day so as not to obstruct the sidewalk or street area. Adequately barricade and red light excavated material off of, but not adjacent to the sidewalk area. Neatly restore sidewalks, driveways, and sodded areas to the satisfaction of the City. Restoration is incidental to the payment of this item and in conformance with Item 1334.

Use an earth auger to excavate; however, in areas of underground utilities, excavate by hand labor. Costs for hand labor excavation near utilities is considered incidental and included in the cost of the associated bid items. At a depth greater than 12 inches (300 mm) below the ground line, place unformed concrete only if the soil on the sides and bottom of the excavation is undisturbed. When encountering soil that tends to cave and form an irregular shape, construct the foundation either by placing additional concrete to fill the excavation, or by constructing a modified pole foundation the Engineer approves. Supply shoring, bracing, and other materials necessary to safely support the sides of the excavation, protecting existing roadway surface, sidewalk and all other existing items adjacent to this work.

C. Existing Conditions. Plans show foundation details for average soil conditions. If, upon inspection of the excavation, solid rock or poor soil conditions are found such as silty clay or wet silt, the City may review the depth and/or width of the foundation to be installed. The City will pay for the additional work and materials needed for increased depth and width at the unit price per cubic yard (m³) for this item.

Stop work and notify the City and the owner of the utility if the Contractor uncovers an existing water main, gas main, sewer pipe or underground conduit while making an excavation for a pole foundation. If the City orders the excavation abandoned, backfill the resulting

excavation with material meeting the requirements of item 613 unless otherwise directed by the Engineer. The City will make payment for this work based on the cubic yards (m³) of excavation performed before stopping work at the unit price bid for the foundation.

D. Placement of Reinforcing and Anchor Bolts. Provide the required reinforcing rods, anchor bolts, and conduit ells in the arrangement as shown on the plans and details in the foundations for anchor base type poles and pedestals. Remove injurious rust from all reinforcing steel and anchor bolts.

Accurately place reinforcing steel and anchor bolts and adequately support by concrete, metal, or other approved chairs, spacers, or ties, and secure against displacement. Make no splices of reinforcement except as shown on the details. Have at least three inches (76 mm) of concrete between reinforcements and the ground contact surface.

Deform reinforcing bars and plain billet steel bars for concrete reinforcing. Meet the requirements of Item 709.01. Assemble reinforcing rods into cages by either wire tying or tack welding. Use forms for the foundation upper square portion. Contractor may use templates to accurately hold anchor bolts until concrete sets. After pole or pedestal erection, use concrete grouting in the space between the metal base and the foundation surface.

E. Inspection. Notify the City in advance as to when the excavation will be completed to the full depth as plans and details require. **Do not fill excavation until the City inspects the excavation complete with the reinforcing steel cage, anchor bolts and conduit ells in place. Foundations that have not been inspected by City Forces are subject to rejection by the City. Costs to replace foundations not inspected by City Forces are the responsibility of the Contractor.**

F. Placement of Concrete. Provide preformed elastic joint sealer conforming to Item 705.11 between all foundations and abutting paved areas. Use 499 Class QC1 Concrete and conform to the requirements of 511. While placing concrete, do not allow concrete to come in contact with the sides of the excavation in such a manner to cause soil to mix with the concrete. Thoroughly consolidate by suitable means during placement all concrete, and work around the reinforcement and embedded fixtures and into the corners of the forms. Protect the anchor bolt threads against damage during concrete placement.

G. Backfill. Contractor may remove forms 24 hours after placing concrete. Remove all forms before backfilling. Use excavated material as backfill. Place backfill in layers and tamp to prevent future settlement of backfill materials. Dispose of the excavated material not needed or backfilled.

Set concrete around foundations for embedded type strain poles with the pole braced in the required attitude (rake) until the concrete sets. Remove bracing after several days.

H. Other Structures. Include foundations for poles and pedestals mounted on bridge structures and walls in the structure and/or wall item. Coordinate the installation of anchor bolts with the structure construction. Contractor may use U-type anchor bolts in lieu of standard anchor bolts.

1319.02 Ground Mount Cabinet Base Breakaway Extension. This work consists of furnishing and installing a breakaway extension for the specified controller or cabinet foundation, which includes cinder brick walls, galvanized extension anchor bolts with coupling, and finishing the walls with sand-cement grout in accordance with the details.

1319.03 Staking. Unless otherwise indicated, provide staking where no locations or staking are dimensioned. Stake in accordance with Item 623. Payment for staking is incidental to the payment of each item for which the stake is provided.

1319.04 Method of Measurement. Foundation concrete is the number of cubic yards (m³) as determined by calculations from plan dimensions, in place, complete and accepted, and includes excavation, reinforcing steel, conduits, concrete, backfilling, and disposal of surplus excavation.

Measure breakaway extension for ground mount cabinet bases as a unit in place and include all extension bolt hardware, cinder brick grouting and finishing.

1319.05 Basis of Payment. Make payment at the Contract price bid per cubic yard (m³) or per unit price bid for the concrete foundation as plans specify, and a per unit price bid for a breakaway extension for ground mount cabinet foundations. The City considers this full compensation for all labor, materials, tools, equipment and incidentals necessary for each item furnished complete in place and accepted.

Item	Unit	Description
1319	Each	Concrete Anchor Base Pole Foundation, ___Ft. Dia. X _____ Ft. Deep, FDN- _____
1319	Cubic yard (m ³)	Concrete for or each anchor base foundations.
1319	Cubic yard (m ³)	Concrete for or each embedded pole foundations.
1319	Each	Ground mount cabinet foundation breakaway extension.

Item 1320 Grounding Equipment

1320.01 Equipment Grounding. Connect all equipment ground wiring and hardware in accordance with the plans and details. Ground all non-current carrying metal parts, poles, pedestals, cabinets, conduit and equipment. Payment for providing and installing the grounding material is incidental to the item grounded, except where installing an equipment ground wire with the ungrounded wiring for circuits. In such cases a pay item will be specified.

1320.02 Ground Rods. Install Ground rods and associated cables in conformance with 625.16. Use copper clad (bonded copper to steel) high strength steel, one inch by 10 foot

(25 mm diameter by 3 m) ground rods. Use minimum No. 4 AWG insulated with 600 Volt Class ground cable, Type RHH/RHW/USE or UF insulation. Connect ground wire from the pole, pedestal or enclosure to the top of the ground rod by exothermic weld or approved one inch (25 mm) ground rod clamp.

Drive ground rod the entire length, with at least one foot (305 mm) of cover, in undisturbed earth and at least one foot (305 mm) from the foundation, unless plans specify otherwise.

1320.03 Structure Grounding. Furnish and install a complete grounding system where plans specify in the plans and in accordance with Item 625.16 and the details.

Use ground rods to conform to Item 1320.02.

1320.04 Method of Measurement. Measure ground rods using as the actual number of ten foot (3 m) lengths and include the cable welded to the ground rod(s) and connections. Measure structural grounding as a unit including all ground rods, cable and connections as plans and details show.

1320.05 Testing of Ground Rods. Resistance test and document each ground rod per Item 625.19.B.

1320.06 Basis of Payment. City will make payment at the Contract unit price bid for each item installed complete, connected, tested and accepted and constituting full compensation for all labor, materials, tools, equipment and incidentals.

Item	Unit	Description
1320	Each	Ground rod
1320	Each	Structural grounding

Item 1321 Conduit, Risers and Trenching

1321.01 Trench, by Depth. Provide trenching where specified in accordance with Item 625.13 and of the depth herein specified.

1321.02 Trench, Paved Areas, by Type. In addition to the provisions of Item 625.13, trench paved areas as details show. Follow existing joints or grooves with premarked sawcut lines where possible. Engineer must approve premarked sawcut lines before commencing sawing work. Restore in accordance with Item 603.10 of this Supplement with backfilling, surface restoration to previous condition and disposal of surplus material.

1321.03 Drain Trench. Excavate to a width and depth sufficient to allow proper connection of drain conduit to proposed sewer connection. Meet the applicable backfilling requirements of Item 603 of this Supplement and Item 625.

1321.04 Conduit. Use conduit of the type and size as specified on the plans. Install the materials furnished and used in this work in accordance with the details and the requirements of Section 625.12. Install all conduit pitched to drain toward the pullboxes which have drain connections to a storm sewer, and include all elbows, fitting and connections. The pull cable must be 3/8 inch (10 mm) minimum braided nylon or polypropylene twist rope rated for 2,500 pounds (10,000 N) breaking load and 250 pounds (1,000 N) working load. Install pull cable in all conduit which will not have circuit wiring or cabling installed during construction.

Use rigid metal conduit of galvanized steel or heavy-wall threaded aluminum and in accordance with Item 725.04.

Use PVC conduit meeting the requirements of Item 725.051 except for the following types:

Type I Schedule 40 - use with Class QC1 concrete or CDF encasement where specified.

Type DB is not accepted.

Type EB is not accepted.

Type II (heavy wall) - schedule 40 min. use for direct burial or on wood poles as specified.

Use drain conduit to sewer lines of cast iron pipe, including elbows and fittings, and meeting the requirements of ASTM A-74.

1321.05 Conduit, Jacked Under Pavement. The work of this item includes furnishing and installing rigid metal conduit meeting the requirements of Item 1321.04, including drilling under paved or sodded areas or other areas designated by the Engineer. The requirements of section 625.14 apply to this item of work as well.

Place conduit under existing pavement or paved shoulder, furnished and installed by jacking or horizontal drilling in accordance with the details, and with the Engineer's approval. When using the drilling method, the bore must not exceed the conduit outside diameter by more than five percent. Install conduit with the least amount of disturbance to existing facilities with all operations maintained within the right-of-way. Backfill push pits or other necessary excavations and restore surfaces in accordance with Item 603.10 of this Supplement.

1321.06 Weatherhead and Conduit Riser. The weatherhead and conduit riser provides a wiring raceway for signal, power and/or lighting cable from a traffic control cabinet, safety switch, lighting controller, pedestrian signal, push button or others as plans specify to the overhead span wire, termination point for service connection and/or an underground pullbox or foundation.

Use Schedule 40 PVC for the weatherhead. Use galvanized steel (per 725.04) or heavy-wall threaded aluminum conduit per Item 1321.04 and PVC Type II per Item 1321.04.

Use galvanized steel or heavy wall aluminum conduit from the ground line up to eight feet (2.5 m) height on the pole. Use Type II PVC for conduit above eight feet (2.5 m).

Drill 3/8 inch (10 mm) drain (weep holes) at all low elevation points in the conduits at elbows as details show. Use conduit clamps of galvanized steel or malleable iron for wood poles and stainless steel banding 1/32 x 3/4 inch (1 mm x 20 mm) for steel poles.

Space clamps or bands five feet (1.5 m) on centers from eight feet (2.5 m) and above grade and 30 inches (750 mm) on center on all conduit below eight feet (2.5 m) above grade.

Provide grounding bushings of OZ No. 2004, M & W GB-550 or approved equal to ground steel conduit where plans specify. Contractor may install PVC conduit directly into the top of a street lighting controller and safety switch, in which case grounding bushings may not be required. Make connections into the top of any enclosure with approved watertight fittings.

1321.07 Conduit Markers. Provide a conduit marker of non-corrosive material as details show and where conduit is specified and installed dead ended beneath grade. Include the cost of this work in the pertinent conduit installation item.

Where plans specify or as the Engineer directs, furnish and install precast or cast-in-place concrete markers as details indicate, and construct in accordance with the applicable requirements of Item 511.

1321.08 Utility Crossover. Provide joint utility conduit as shown in the Subdivision Manual. Install four wide by two high, four-inch PVC schedule 40 conduits, concrete encased unless noted otherwise on the plans. Do not continue concrete encasement to the end of the conduit.

1321.09 Method of Measurement. Measure trenching as the number of feet (meters) of trench from center to center of foundations, pullboxes, etc., and include all excavation, backfill, compaction, disposal of surplus material and restoration of disturbed facilities and surfaces.

Measure conduit as the number of feet (meters) of conduit furnished and installed from center to center of pullboxes, foundations, etc., and include all fittings, appurtenances, joints, bends, grounds and concrete encasement where plans specify. Combine conduit and jacking into one pay item where plans call for jacking.

Measure horizontal boring or jacking conduit as feet (meters) of boring from center of foundations, pullboxes, etc., and include all fittings, appurtenances, joints, bends, grounds, and concrete encasement where plans specify.

Measure weatherhead and conduit riser as a complete unit, in place, by conduit diameter including all fittings, clamps, banding, bushings and weep holes.

Measure conduit markers as a complete unit precast and/or cast in place.

Measure utility crossover as the number of feet of furnished and installed conduit grouping measured from end of crossover to end of crossover, including all appurtenances, joints, caps, and concrete encasement. Do not measure individual conduits.

1321.10 Basis of Payment. City will make payment at the Contract unit price bid for each of the items as Contract specifies, furnished complete and in place, and including all labor, material, tools, equipment and incidentals necessary.

Item	Unit	Description
1321	foot (meter)	Trench, _____ inches (mm) deep.
1321	foot (meter)	Conduit, jacked or drilled under (specify sod or pavement) _____ inches (mm) (nominal diameter).
1321	foot (meter)	Trench, paved areas, less/more than 6" (150 mm)
1321	foot (meter)	Drain trench
1321	foot (meter)	Conduit, _____ inches (mm) (diameter) (specify type) _____ (specify concrete encasement or jacked under pavement where required).
1321	Each	Weatherhead and conduit riser, _____ inch (mm) _____ (diameter)
1321	Each	Conduit marker
1321	foot (meter)	Utility Crossover

Item 1322 Electrical Boxes

1322.01 Concrete Pullboxes. Construct pullboxes by size and type as plans specify and as details show. Excavate as nearly as practicable to the outside dimensions of the pullboxes. After setting pullboxes to proper grades, backfill excavated spaces around pullboxes with suitable material and tamp in thin layers.

Install pullboxes cast-in-place using Class QC1 concrete with the frame cast integral with the pullbox in areas surrounded by sod or soil. In areas surrounded by sidewalk, cast frames integral with the sidewalk. Form the inside wall of the pullbox and fill voids between the frame and top of pullbox with concrete from the sidewalk pour. If voids are present after the sidewalk pour, fill with non-shrink grout. Cast end bells and couplings for conduit entrances with the

pullbox or block out a section of each of the walls prior to the casting, then grout the end bells and couplings into place. Provide reinforcing steel in all pullboxes installed in streets and driveways. Where plans specify drainage, provide the pullbox with a concrete floor, a three-inch (75 mm) drain conduit, a cast iron strainer, and a 1/2-inch (12 mm) preformed joint sealer conforming to Section 705.11 between all pullboxes and abutting paved areas. Grout and finish all openings and spaces to the satisfaction of the Engineer. For all pullboxes in sidewalks or street areas, cast frame and lid integral with final sidewalk or paving. City will not permit precast pullboxes with integral frames and lids in these areas.

Install cast iron frames meeting the requirements of ASTM Specification A-48 Class 30 for regular duty pullboxes and ductile iron meeting the requirements of ASTM Specification A-536 Grade 60-40-18 for street duty pullboxes. Furnish frames and covers of uniform quality, free from blow holes, porosity, hard spots, shrinkage defects, cracks, warps, or other injurious defects.

The Contractor may furnish precast pullboxes as an alternate, constructed of reinforced Class QC1 concrete and meeting as a minimum all dimensions and requirements for cast-in-place pullboxes. Cast frame integral with the pullbox in areas surrounded by sod or soil. In areas surrounded by sidewalk, cast frames integral with the sidewalk. Form the inside wall of the pullbox and fill voids between the frame and top of pullbox with concrete from the sidewalk pour. If voids are present after the sidewalk pour, fill with non-shrink grout.

1322.02 Downtown Special Pullboxes, 22 inches x 22 inches (554 mm x 554 mm). In Addition to the requirements of Item 1322, furnish and install all Downtown Special (Non-Roadway) 22 inch by 22 inch pullboxes with covers meeting the following specifications:

Provide pullbox covers with dimensions that conform to those shown in Std. Drawing ES-2-1. Construct pullbox covers of polymer concrete consisting of sand and aggregate bound together with a polymer resin. Construct the cover monolithically to limit stress cracks due to differing coefficients of thermal expansion. Use only matched metal tooling to manufacture the product to assure consistent production from part to part. Provide covers with the following dimensions: 21-13/16 inch by 21-13/16 inch, with a 15/16 inch bearing ledge (554 mm x 554 mm x 24 mm). Provide covers with dimensional tolerances of $\pm 1/16$ inch (1.6 mm) except overall length and width dimensional tolerances ($\pm 1/8$ inch [3.2 mm]). Provide covers that weigh 60 pounds (27 kg) ± 10 percent. Provide covers with bottoms that allow flush mounting on a flat surface to prevent entry of foreign objects. Provide covers with the following minimum allowable properties:

A. Load Testing. Distribute vertical load over a 10 inch by 10 inch (254 mm x 254 mm) area. Apply load with a 10 inch by 10 inch x 1 inch (254 mm x 254 mm x 25 mm) thick steel plate backed with a 1/4 inch (6 mm) thick rubber shim. Use a spherical bearing swivel head in the testing machine. Center the loading pad over the portion of the cover which will produce the maximum deflection under load. Take deflection measurements perpendicular to the cover and wherever maximum deflection occurs. Position deflection measurement device or devices so as to measure only the deflection of the cover.

Support the cover along the total length of all four sides. Use a supporting surface with a maximum width of one inch (25 mm). The Loading Diagram is shown on Drawing B.

The design load for the cover is 8,000 pounds (3,630 kg). The cover must pass a static load test of 12,000 pounds (5,450 kg) which represents the design load multiplied by a factor of safety of 1.5. The cover must sustain a 8,000 pound (3,630 kg) pound load with no more than 1/2 inch (13 mm) deflection.

B. Chemical Resistance. Test according to ASTM D-543, Section 7, Procedure 1 using the following chemicals in the concentrations noted:

1. Sodium Chloride5%
2. Sodium Carbonate 0.1 N
3. Hydrochloric Acid0.2 N
4. Acetic Acid5%
5. Transformer Oil Per ASTM D-543
6. Sulfuric Acid0.1 N
7. Sodium Sulfate0.1 N
8. Sodium Hydroxide0.1 N
9. Kerosene Per ASTM D-543

C. Flexural Strength. Test in accordance with ASTM D-790.

D. Accelerated Service. Test in accordance with Procedure E, ASTM D-756.

E. Water Absorption. Test in accordance with ASTM D-570, Section 5, 6.1 and 6.5.

F. Impact Resistance. Provide covers that can withstand a 70 foot-pound (95 N-m) impact at any point on the cover administered with a 12 pound (5.5 kg) weight having a "C" TUP (ASTM D-2444) without puncturing or splitting. Perform the test with the cover resting on a flat, rigid surface such as concrete or a one inch (25 mm) steel plate.

G. Skid Resistance. Provide skid resistant covers with a minimum 0.50 coefficient of friction molded on the top surface of the cover. Coatings are not acceptable.

H. Flammability Test. Test in accordance with ASTM D-635.

I. Ultraviolet Exposure. Test in accordance with ASTM G-53 using an U.V.A. 340 bulb.

J. Material Retention. Except for the Flammability Test, the minimum acceptance criteria for material is 75 percent of the control specimen values. For Load and Deflections, no more than two percent change in weight or any dimension, no visual cracking, crazing, checking, blistering, or surface pitting. For the Flammability Test, the burning rate must be less than 0.3 inches in length for each 0.1 inch of thickness (0.3 mm for each 0.1 mm)

K. Temperature Range. Design the cover to be suitable for installation and use through a temperature range of -40° F to $+140^{\circ}$ F (-40° C to $+60^{\circ}$ C).

Assume responsibility for proof of compliance with the latest version of the ASTM standards. Attach MSDS in weather-tight vessel to each order. Provide and submit to the

Engineer prior to shipment of materials certified test reports signed and stamped by a Professional Engineer registered in the State of Ohio. Provide covers that are Quazite, CDR Systems or approved equal.

Provide covers in colors approved by the Engineer. Provide covers with pick holes along the middle of one side.

Submit one sample of the cover proposed for use to the Engineer for approval prior to ordering.

1322.03 Junction Boxes. Specifications include: fabricated of hot dipped galvanized steel in accordance with ASTM A-123, raintight, and UL approved and installed as details show. The work of this item includes all approved mounting hardware of a non-corrosive material. Where embedding junction boxes in concrete structures, provide the boxes with drains.

1322.04 Sectionalizers. Install sectionalizers consisting of terminal strips and cabinet for mounting on poles in the vicinity of the interconnecting cable line. Install and mount hardware according to plan details.

Provide sectionalizer with barrier-type terminal strips rated for a minimum of 600 volts insulation. Furnish terminal poles rated for a minimum of 30 amps of the tubular screw type with pressure plate sized from 1 to 3 No. 12 AWG wires. Install terminal strips with twelve poles. Install the type and number of strips plan details require.

Furnish terminal strips with frames of bakelite, nylon or approved high-quality insulating material.

As an alternate, the sectionalizer terminal strips may consist of poles provided with sliding or movable links, for opening and closing circuits without disturbing any connected wiring, and designed to prevent accidental contact with adjacent poles when opened. Install nuts, bolts, links, lugs and washers of silicon bronze metal, nickel-plated, stainless steel or approved equal. Install insulating posts, barriers and terminal frames of bakelite, nylon or approved high quality insulating material rated for 600 volts (minimum). Provide bolts that are cast with the terminal frame molding for a most rigid pole.

Mount the terminal strips in the cabinet on stand-offs as details show.

Install weatherproof and raintight cabinets meeting the requirements of NEMA Type 3R and equipped with approved wing type, butterfly link lock or luggage type stainless steel latches.

A type I sectionalizer is 14 inches high by 8-1/4 inches wide by four inches deep (356 mm x 210 mm x 102 mm). It has two quick release door latches and houses a 24 terminal barrier strip. Provide type I sectionalizers on overhead routes where the cable specified is six or 12 pair. A type II sectionalizer is 24 inches high by 8-1/4 inches wide by four inches deep (610 mm x 210 mm x 102 mm). It has three quick release door latches and houses a 50 terminal barrier strip. Provide type II sectionalizers on overhead routes where the cable specified is 25 pair.

1322.05 Method of Measurement. Measure pullboxes as a complete unit, in place, including excavation, forms, concrete Class QC1 , frame and cover, reinforcing steel, grouting fittings, strainer/cesspool, aggregate, 1/2 inch (13 mm) expansion joint, backfilling and restoration of the immediate area.

Measure junction boxes as a complete unit, in place, including all mounting hardware, anchors and drains.

Measure sectionalizers as a complete unit, in place, including cabinet, terminal strips, lugs, connections, mounting hardware, reversible clamps and testing.

1322.06 Basis of Payment. The City will make payment at the Contract unit price bid for each item furnished and installed complete and accepted, including all labor, materials, tools, equipment, and incidentals.

Item	Unit	Description
1322	Each	Pullbox, concrete, ____ inches (mm) x ____ inches (mm), type
1322	Each	Junction box, ____ inches (mm) x ____ inches (mm) x ____ inches (mm)
1322	Each	Sectionalizers, ____ type
1322	Each	Reuse Existing Pullbox, ____ inches (mm) x ____ inches (mm),
1322	Each	Pullbox, concrete, ____ inches (mm) x ____ inches (mm), type ____, installed over existing conduit

Item 1323 Cables, Connectors, and Accessories

1323.01 Cable, By Type and Size. Install and route cable and wire by size and type as plans and details specify. Furnish cable and wire with the specified number and size of conductors, the required insulation voltage rating and cable service type specification.

Mark all cable and wire jackets indelibly every five feet (1.5 m) showing the Manufacturer's name, wire size, voltage rating, and type and style.

Where plans and specifications designate cable outer jacket coloring, furnish cable manufactured with an outer jacket of the color specified.

Furnish all cable and wire rated at 600 volts except CTCS Cable with conductors of solid copper unless plans specify otherwise. Cable by type to meet the following requirements:

A. Service Cable. Install serial self-supporting cable with an aluminum clad steel support wire as electrical neutral (duplex or triplex) or two conductor or two each one-conductor power supported with a 1/4 inch (6 mm) messenger cable per Item 1323.02. Duplex or triplex cable to be neoprene or cross-linked, polyethylene insulated conductor(s) (one for duplex, two for triplex), cabled around a bare seven-strand ACSR neutral messenger of the same AWG size as the insulated conductor(s) except that the ACSR messenger must be no smaller than No. 4 AWG.

B. Service Cable (duplex or triplex as specified). Install aerially from a remote power source to the structure or pole housing, street lighting controller or disconnect switch. Use a No. 6 SE2 with ground to complete the connection between the disconnect switch and the traffic signal controller.

C. Power Cable. Furnish two single stranded copper conductors or a two-conductor cable and install from the local source to the disconnect or controller enclosure. Install cable type RHH/RHW/USE insulated with sufficient excess cable to allow Duke Energy crews to connect to their secondary or service point.

Where plans specify traffic signal controllers, route power cable in a separate 1 inch (25 mm) conduit from the controller cabinet to the service connection.

D. Feeder and Pole and Bracket Cable. Install RHH/RHW/USE insulated. Provide conductors in colors as indicated on the plan sheets. Cable to be colored by permanently color impregnating the conductor's outer jacket along its entire length during the manufacturing process.

E. Series Street Lighting Cable. Install No. 8 AWG, solid copper, single conductor, rated 5000 volts, 60 hertz, A.C., rubber insulated, neoprene jacketed for direct burial service. Minimum insulation thickness is 10/64 inch (4 mm) and minimum neoprene jacket thickness is 4/64 inch (1.5 mm).

F. Traffic Signal Cable. Install cable meeting the requirements of IMSA Specification 19-1 or 20-1 with Solid or Stranded Copper conductors. Install Signal cable between signal heads and controller cabinets and install interconnect cable between controller cabinets of different intersections, as plans show. Furnish signal and interconnect cable suitable for aerial installation, supported by messenger wire or for routing within underground conduit. Furnish electrically shielded interconnect cable when plans specify for installations where performing multiplexing or where transient electrical impulses could be detrimental. Install shield type interconnect cable meeting the requirements of IMSA 19-2 or 20-2.

G. Electrical Cable for electrical signs and island lighting. Install two conductor, type RHH/RHW/USE or UF insulation. The City may accept cable furnished with insulation meeting ISMA 19-1 or 20-1.

H. CTCS Cable - Computerized Traffic Control System Cable. Install twisted pair, shielded communications cable #19 AWG or #24 AWG, unless plans specify otherwise.

Install cable meeting the Rural Electrification Administration (REA) specification PE-89, type BJFC and flooded (filled) with a petrolatum - polyethylene translucent gel compound applied in a Liquid State. Furnish cable applicable for direct burial service, installations in underground conduit and aerial routing when supported by a separate messenger cable.

During pulling, lubricate the cable continuously as it enters the conduit. Use lubricant compatible with the cable jacket as recommended by the cable manufacturer. Use liquid detergent. Do not exceed the cable Manufacturer's recommended pulling speed and pulling tension.

Furnish Cable with conductors of solid, soft drawn, annealed bare copper, and insulation of solid, virgin high density polyethylene or polypropylene, with standard telephone industry color coding. Cable core to be insulated conductors twisted in pairs, with shielding of 0.005 inch (0.13 mm) solid copper tape and overlap to provide 100 percent electrical shielding coverage. Furnish cable with black outer jacket, low density, high molecular weight virgin polyethylene and able to withstand sunlight and temperature variations.

Provide Cable with number of pairs as specified.

I. Loop Detector Wire. Furnish No. 14 AWG, THWN, stranded of a continuous length from the spliced connection to the pair of shielded conductors in the lead-in cable splice or controller terminal when directly connecting the loop wire. Protect the loop wire with a flexible vinyl plastic tubing, of 3/16 inch (5 mm) I.D., a minimum of 1/32 inch (1 mm) wall, and 1/4 inch (6.4 mm) O.D. Furnish tubing capable of resisting deterioration from oils and solvents and highly abrasion resistant with a smooth bore. Insert the wire into the vinyl plastic tubing for the full length from the point of splicing and place it into the slot with the number of turns as plans show, or as the Engineer directs. Install tubing of a continuous length from the point of splicing of the loop wire to the lead-in cable. Make no splices in the tubing. Push the wire carefully into the slots with a blunt tool to avoid damaging the insulation.

When placing the loop wire in the sawed slots, seal the ends of the tubing within the splice to prevent any entrance of moisture.

Twist all lengths of loop wires and tubing not imbedded in the pavement with at least five turns per foot (16 turns per meter), including lengths in conduits and pullboxes.

Where plans specify, provide a conduit fitting on a riser in lieu of a pullbox for detector wire and lead-in cable splicing. Include in payment the flexible vinyl plastic tubing and conduit fitting where spliced in the cost of the Loop Detector Wire.

J. Loop Detector Lead-in Cable. Install to connect the loop detector wire to the loop detector amplifier. Splice the lead-in cable to the loop wire in pullboxes with approved watertight splices meeting Item 1323.04. Solder the connections together in a butt splice or use approved crimping connectors in conduit fittings where plans specify (where the loop wire has no pullbox for splicing) and insulate each cable in the splice individually with approved weatherproof electrical tape. Wrap the entire splice with approved weatherproof electrical tape and finish the splice by enclosing it in approved heat-shrink tubing.

Provide twisted multi-pair lead in cable (as plans require). Install No. 14 AWG, shielded, polyethylene insulated, chrome vinyl jacketed cable rated 750 volts for 14 AWG. Ground the shield only at the amplifier.

Installations: allow excess cable at weatherheads and power service connections for sufficient drip loops.

Provide additional cable for pullboxes, connections to equipment and as specifications indicate in the method of measurement to insure sufficient slack in underground installations.

1323.02 Messenger Wire. Install messenger cable of copper clad steel, stranded and sized as specifications indicate, including lashing wire and all accessories as the plans and detail show.

Furnish messenger wire meeting the requirements of ASTM specification B228 grade 30 EHS with mechanical properties as follows:

City Size Designation	Strand Size	O.D. of Wire Approximate	Minimum Breaking Strength
1/4"	(3 Each) No. 9 AWG	0.247" (6.27 mm)	5,129 lb. (22,815 N)
	or (7 Each) No. 12 AWG	0.242" (6.15 mm)	5,670 lb. (25,221 N)
5/16"	(7 Each) No. 10 AWG	0.306" (7.77 mm)	9,196 lb. (40,906 N)
3/8"	(7 Each) No. 8 AWG	0.385" (9.78 mm)	12,890 lb. (61,786 N)

Install messenger wire with the entire load of signal equipment giving a sag of three percent of the span length. Exercise due caution when stringing and loading the messenger wire so that the strain poles, either momentarily or for any period of time, are not loaded to permanent set (load at yield stress).

Furnish lashing wire of No. 14 AWG bare solid copper wire and apply to tightly wrap all signal cable to the messenger wire at the rate of two turns per foot (six and one-half turns per meter). Terminate the lashing wire to the messenger with approved split-bolt connectors. With approval of the City Traffic Engineer, Contractor may use copper preformed lashing rods in lieu of the No. 14 wire.

Specifications for bull ring aerial corners, crossover clamps, three-bolt messenger clamps (guy grips), thimble eye through bolts and messenger hangers include drop forged steel and hot dipped galvanizing in accordance with ASTM specification A-153 and a designed holding strength without slipping or breaking of at least 10,000 pounds (45,000 N).

Fasten the messenger wire at the poles with thimble eye through bolts (wood poles) or with two wraps around the pole (steel poles) and secure with a three-bolt messenger clamp with the wire end served into a 130 to five to seven inch (180 mm) mause. The City will permit self wraps at thimble eye through bolts and bull ring aerial corners.

1323.03 Connector Kits. Install connector kits meeting the requirements of Item 725.15 for the type plans specify, in accordance with the plans and details.

Furnish Fusible Type kits with UL Class CC - 600 Volt fuses, ten amp unless plans specify otherwise.

1323.04 Splice Kits. Provide all labor and materials where plans specify splicing or in accordance with the details or as the Engineer directs. Install Kits in compliance with ANSI C119.1 for "permanent water resistant cable splicing kit" and meet the requirements of Item 725.15. Splice ratings for series circuits are 5,000 volts.

Splice Multi-conductor (three or more conductors) cable in accordance with the details in Standard Drawing ES-3-9.

The City does not permit splices in saw cuts or conduit. Correctly measure the cable to prevent unnecessary or unapproved splices. Contractor may make splices in pullboxes, cabinets and as details show.

City must approve all splices incidental to the item of cable to be spliced.

CTCS underground splice boxes. Splice twisted-pair cables in waterproof splice cases located in City-owned pullboxes, or in aerial sectionalizer cabinets mounted on utility poles. Contractor must make underground splices in splice cases of the two-type closure system manufactured by PSI Telecommunications, Inc. of Burbank, California, or approved equivalent.

Use splice enclosures made of fiberglass, manufactured by Stahlin, model # J1210HPL, type 4X and model #J806HPL, type 4X or equivalent. Splice cables by attaching the conductors to the terminal blocks provided within the cabinets. Bond the cable shield to ground at only one end of each cable. Use 3M Scotchlox model 4460 Shield Connectors or equivalent to bond the cable to ground. At every sectionalizer cabinet and underground splice where a ground connection is available, do not bond the cable coming from the control center (incoming cable). (The bond for the incoming cable originates at the source of the cable). Bond all other cables exiting from each splice. If a ground connection cannot be obtained at a splice point, make all shields common to each other to obtain the bonding connection from the previous splice point.

The cost of tooling and splices is incidental to the installation of the cable.

1323.05 Connections. Notify City of Cincinnati forces to make connections with a live master or CTCS cable. Make connections with a de-energized master or CTCS cable. City of Cincinnati will approve all connections and the Contractor-tested circuit before final connection to the energized master line.

When disconnecting a series lighting circuit to splice cables, notify Duke Energy to provide the cut out and cut in service.

Duke Energy personnel will make all connections and disconnects with the Duke Energy's systems.

1323.06 Method of Measurement. Measure cable in place, complete and accepted. Aerial cable measurements include pole attachment hardware and splice enclosures. Lead-in cable measurements include poured epoxy insulated splices. Measure: (a) horizontally from center to center of pullboxes, poles, cabinets, power sources, and electrical devices with an additional allowance of five feet (1.5 m) at each pullbox, pole, etc. for slack and connections; and (b) vertically between pole or conduit outlets. When substituting single conductor power cable for multi-conductor cable, City will pay based on the required length of multi-conductor cable. Power cable includes any costs incurred to arrange the service installation by the supply agency.

Measure loop detector wire from the pullbox center to the pavement edge, the actual feet running in the pavement loop slots depending on the number of turns laid, and returning to the pullbox, plus five feet (1.5 m) at each end for slack and splice.

Measure messenger wire in place, complete and accepted, and including all necessary accessories such as thimbles, clamps, bullrings and lashing rod. Measure from pole center to pole center, or pole center to bullring, or bullring to bullring, as specifications require. The measurement does not include any length of messenger wire for attachment to poles, or bullrings by bending, lapping or wrapping.

Measure connector Kits in place as a complete unit, accepted, including fuses as required. Splice kits are normally included with the item of cable; however, where specified, measure splices in place, complete and accepted as a unit item.

1323.07 Basis of Payment. City will make payment for accepted quantities of cables, wire, connectors, and kits and full compensation for all labor, materials, tools, equipment and incidentals necessary for each item furnished complete, with all connections made and wiring tested and accepted.

Item	Unit	Description
1323	Foot (meter)	___ Cable/wire ___ conductor No. ___ AWG
1323	Foot (meter)	___ pair of CTCS Cable ___ AWG
1323	Foot (meter)	Service cable, ___ plex, No. ___ AWG
1323	Foot (meter)	Messenger wire, ___ strand No. ___ AWG, (___diameter) with accessories
1323	Each	Connector Kit, type ___ with 10 amp fuse (where applicable)
1323	Each	Cable Splicing Kit

Item 1324 Traffic and Lighting Controls

1324.01 Photo-Electric Cell. Provide photoelectric control with a solid state, cadmium sulfide type cell with hermetically sealed silicon rectifier and rated surge protector for a fail-safe operating 120 volts, 60 Hz. Also, include a built-in feature so that lighting circuits will remain energized in the event the photo control components become inoperative.

The relay contact rating is 500 watts minimum with an in rush capacity of 900 volt amperes and capable of operation within temperature range of 30° F to 130° F (–1° C to 55° C). Make relay contacts snap acting to minimize arcing. Make switch leaves on which contacts are mounted independent of thermal elements.

The sensing element operating range is from 0.5 to 1.5 FC (5 to 16 lx) "ON" and 1.5 to 4.5 FC (16 to 50 lx) "OFF" operation foot candles. Provide a hermetically sealed cell with three locking type blades that fit a socket which meets E.E.I. Pub. No. 148 and N.E.M.A. Pub. No. 18 standards.

Furnish a device with a time delay of a least 15 seconds incorporated into the switching operation to prevent switching due to lightning. Include on the device a socket mounted on a pole top or bracket adapter with wiring terminals, and all mounting hardware.

Furnish and install three No. 14 AWG, 600 volt, type RHW/USE cables from the photo cell to the lighting controller. Observe the following color code:

Black Wire for "line"

Red Wire for "load"

White Wire for "Neutral"

Mount the photo-electric cell at least 25 feet (7.6 m) or more up on the designated pole above any artificial light or street lighting, and orient with the sensing element facing north.

1324.02 Street Lighting Relays. Provide Street lighting relays and install them in pullboxes or cabinets as plans specify in accordance with the plans and details. Use them where luminaires serve from underground vaults and where the use of street lighting controllers are precluded.

Provide relays for one or more luminaires as plans indicate, but restricted to serving no more than two 1,000 watt metal halide type luminaires.

Provide the relay in a weatherproof housing of aluminum, molded fiberglass or other approved non-corrosive material.

Equip the relay with normal closed type mercury wetted contacts rated for 30 amps (minimum) and with the coil operated at 120 volts. Adams & Westlake Cat. No. 1140-50-7A, Permatrol No. 64-RE-850 South Bend Controls, Inc. No. MRR-TD-6246 or approved equal.

Include with the relay an approved lighting arrestor with a 30 amp cartridge type fuse (UL Class SK-1) connected to the line side of the relay contacts.

Provide mounting brackets and approved non-corrosive hardware.

1324.03 Lighting and Traffic Control Disconnect Devices.

A. General. Install Street Lighting Controllers and/or safety switches of the size plans specify and in accordance with the details.

B. Enclosure. Provide a NEMA type 4X enclosure fabricated from No. 16 gage or heavier AISI Type 302, 303, or 304 annealed stainless steel. Fully weld all seams to and all fastenings in the assembly or mounting of the enclosures to conform to ASTM A-320 (AISI-300 Series).

Furnish each enclosure with a door so constructed that it may not be opened when the disconnecting handle is in the "on" position.

The front mounted switch handle will not be part of the door. Make the door single piece full length construction, hinged on the left side (facing the front of the enclosure) with latching device dogs near the top and bottom.

Provide the door with a mechanism interlocking the door latch and the operating handle, including provision for padlocking both in the "on" and "off" position. The defeatable mechanism will use the following sequence when the operating handle of the disconnecting device is in the "on" position: (1) Release door latch with one hand on door latch handle while simultaneously operating door latch defeater screw with a screwdriver in the other hand. (2) Open door with one hand on door latch handle while simultaneously operating disconnect handle defeater screw with a screwdriver in the other hand.

Recess the door latch defeater screw sufficiently within its housing so that it cannot be turned with a coin or flat washer.

Provide the door latch mechanism so the door handle must be turned to fully engage its latch before the disconnect handle can be moved to the "on" position.

C. Components. Furnish the enclosure with the following factory wired units mounted on a removable panel:

1. One two-pole or three-pole (as indicated below) heavy duty fusible disconnect switch rated for 600 volt class.

a. Three pole -- for street lighting controllers.

- b. Two pole, three wire, two fusible poles with solid neutral -- for safety switches.

Install adjustable fuse clips and sized for up to 250 volt cartridge type fuses. Furnish fuses that are 120 or 240 volt size as per the voltage application required and UL Class RK-1, fast acting, current limiting with minimum 200,000 amps interrupting capacity; BUSS Limitron Series, E-Shawmut Amp-Trap Series or approved equal. Furnish switches with fuses as specifications indicate in Table 1324.03. Cable sizes for copper cables only.

Table 1324.03

Enclosure Size (Amperes)	Power Cable No./Size (AWG)	Enclosure Nominally Furnished Fuse Size (Amperes)	Power Service Conduit Riser	Neutral Bar Lug Sizes
200	3 #3/0 Cables 2 #3/0 Cables	200	2" (53 mm) 2" (53 mm)	2 each #3/0 to 250 kcmil 8 each #4 to 4/0
100	3 #1 Cables 2 #1 Cables	80	1-1/2" (38 mm) 1-1/4" (32 mm)	2 Each #1 to 2/0 8 Each #4 to 1
60	3 #4 Cables 2 #6 Cables	45	1-1/4" (32 mm) 1 inch (25 mm)	2 Each #4 to 1 8 Each #8 to 4
30	3 #6 Cables	25	1 inch (25 mm)	10 Each #8 to #4

Where requiring 240 volts, use sizes specified with three wires. For 120V systems use sizes specified with two wires.

2. One neutral bar with ten tubular screw lugs size as per Table 1324.03.
3. One Cabinet ground lug.
4. For Street Lighting Controller Only. One three pole lighting contactor. Contactor coil 120 volts, 60 Hz. with contacts rated for tungsten and ballast lamp loads as follows:
 - a. 480 volts maximum line to line voltage.
 - b. 277 volts maximum line to neutral voltage.
 - c. 250 volts DC.
 - d. One three-position Selector Switch, rated minimum ten amps, 600 volts, for "HAND OFF-AUTO" control.
 - e. Locate the switch inside the enclosure.
 - f. (Furnish only if specified) A Time Delay Relay "time out with Power interruption" type 120V 60 Hz, two each SPST or one DPDT isolated contacts rated ten amps minimum approximately one to 60 second timer set for 20 seconds, Ambient Temperature

Range -40° to +120° F (-40° to +50°C). Furnish relay equipped with surge protection and Octal Socket. Potter-Brumfield Model CDB-38-70012 or approved equal.

5. Enclosure Facilities. Make provisions for connecting external wiring into the enclosure. Mark the "line" and "load" leads and make them easily accessible.

a. Provide two mounting flanges on the outside of the enclosure, one on the top and one on the bottom. Drill or slot the flanges for mounting bolts or screws. Fabricate so as to leave no sharp corners or burrs.

b. Furnish cabinet large enough to admit a three-inch (75 mm) conduit hub in either top, bottom, or back near bottom to allow entrance of external circuits and not disturb normal function of internal units.

c. Drill a 3/8" weep hole in the bottom of the cabinet to provide for the dispensation of moisture. Provide wiring space of two inches (50 mm) between housing and internal units. Furnish each switch enclosure with a padlock. Padlocks to be master No. 500 KA series or equal by Russwin, Corbin or others but keyed to accept master No. 255 key change.

6. Mounting Hardware. Furnish Mounting hardware, galvanized steel lag screws (for wood pole mounting) or stainless steel banding 1/16 x 7/8 inch (1.5 x 22 mm) dimension (for steel pole mounting).

Mount the enclosure on poles with the top of the enclosure ten foot (3 m) above grade.

1324.04

Tr

affic Signal Controller

A. Installation Only. The work of this item consists of hauling and installing the signal control equipment, including signal controller, detector amplifiers, control cabinet with base (for ground mounted types), all of which the City of Cincinnati will furnish in accordance with the details and plans.

Make the installation complete and ready to operate from a 120 volt, 60 Hz. electrical service.

Make all terminal strip connections between the controller and signal heads, pedestrian signals, signs, detectors, push buttons, and de-energized interconnecting cable. Install and wire all control equipment to produce the intended color sequence display and signal operation.

Where specifications call for the cabinet as the ground mounted type, install the cabinet on the foundation provided under Item 1319.01.

Where specifications call for the cabinet as the pole mounted type, install galvanized hanger plates on the cabinet using stainless steel nuts and bolts and maintaining the cabinet watertight. Fasten the cabinet to wood poles with galvanized lag screws and to steel poles with 1/16 inch by 7/8 inch (1.5 x 22 mm) stainless banding. For steel poles, install a three inch (80

mm) galvanized steel or cast aluminum conduit ell from the cabinet bottom into a nipple welded in the pole for a wiring raceway, unless otherwise specified. Install a pole mounted cabinet with 2/3 of the cabinet height five feet (1.5 m) above ground and mount on the side of the pole away from the street (field side), as plans show.

B. Furnish and Installation. The work of this item includes supplying and installation of the signal control equipment including signal controller, detector amplifiers, and control cabinet.

Supply a new controller unit type as stated in the plans, 330 CIN cabinet, loop detector amplifiers and all associated equipment to make the traffic signal operational and complete. Controller, Cabinet and all associated equipment must be in conformance with the latest City of Cincinnati Contract for Programmable Traffic Signal Controllers. Submit manufacturer catalog sheets to the Engineer for approval prior to ordering any of the new traffic signal controller components. Contractor to notify Engineer and arrange delivery of the new, complete controller units to the Department of Public Services 30 days prior to the date the unit is needed for installation. City forces will program the controller with the proposed timing of the signal. Contractor to pick of the controller from Public Services and install as described on the plans. Install ground mounted controllers on foundation in accordance with Items 1319.01 and install pole mounted controller on pole and reference angle as shown on the plans.

Furnish all labor, equipment, materials and incidentals for complete installation of the traffic signal controller. Comply with Item 1324.04A for the installation of the traffic signal controller and furnish all necessary mounting hardware.

1324.05 Auxiliary Traffic Control Cabinets.

A. General. Furnish and install traffic control cabinets as plans specify, including all components and parts as required for each type of application intended or specified for the cabinet. Furnish each unit complete, ready for service and installed in accordance with the plans and details.

B. Cabinet. Provide a cabinet of corrosion resistant, weatherproof, NEMA type 3R, constructed of cast aluminum material with strength equivalent to 3/16 inch (5 mm) thick material having a minimum yield strength of 18,000 pounds per square inch (125,000 kPa) or corrosion resistant steel sheet at least 0.06 inch (1.5 mm) thick or 16 gauge AISI type 302, 303 or 304 annealed stainless steel.

Provide a cabinet free of cracks, burrs, blowholes, casting flashes and any excess material or imperfections.

Cast or construct a gasket groove around the periphery of the door and/or cabinet housing and insert a neoprene gasket in the groove to provide a watertight and dust tight seal between the door and housing.

Provide a double hinged door with stainless steel hinge pins and a latch bolt, steel armored, self-locking with a dust cover keyed to the City of Cincinnati standard (Corbin Key Change No. 1R 6380).

Paint the exterior of an aluminum cabinet with an aluminum color finish coating accordance with Item 1317.

Furnish cabinets equipped with fans and all ground mounted (Type G) cabinets with vents at the top (where fan is furnished) and at lower sides of the cabinet. Provide vents suitably baffled and screened for protection against moisture, dust and insects.

Furnish Cabinet doors, except door-in-door, with a bar stop-catch to retain door in an open position at an angle of between 120 degrees and 135 degrees.

Furnish Type PL and G cabinets with a door-in-door (police door) located in upper front center of cabinet door. Provide the door-in-door with gasket as plans specify for the main cabinet door to provide a water and dust tight seal. The door-in-door provides access to a recessed panel or wall but not the interior of the cabinet. Make the recessed panel of sufficient size to house up to five switches and a manual control cord.

Make the key for access to the door-in-door Corbin No. 0357SGS, Crousehinds No. KL-3123, Eagle Signal Company No. E-7322 or approved equal having the same key change.

C. Installation. Provide pole mounted (Type P and PL) cabinets equipped with mounting flanges or plates on the top and bottom for fastening to poles. Furnish mounting hardware and accessories for fastening to wood and steel poles. Field drill conduit entrances into the cabinet and only into the bottom of the cabinet.

Field drill pedestal mounted (Type P and PL) cabinets for mounting on the specified pedestal. Provide all nuts, bolts and washers for securing cabinet to pedestal of stainless steel, cadmium plated or corrosion resistant metal. Provide a neoprene or suitably equivalent gasket to seal the pedestal hub to the cabinet. Furnish the pedestal (Item 1318.02 specifies "pedestals") and provide it with a flanged hub which will be incidental to the payment of the cabinet.

Furnish ground mounted (Type G) cabinets with base and anchor bolts. Make the foundation, anchor bolt construction, size and placement as detail sheet indicates for Type I (regular). Install the cabinet on the foundation provided under Item 1319.01.

D. Components for All Types and Applications. Furnish Cabinets with the components as specified herein and as Table 1324.F.2 lists for the traffic control application specified.

1. Lighting Arrestor to meet the following minimum requirements:
 - a. Voltage Class: 125 volts - single pole.
 - b. 60 Hz Sparkover: 1000 volts rms.
 - c. Critical Impulse Sparkover: 2400 volts
 - d. (1-1/1 x 40 MS wave).

- e. Discharge voltage at 10,000 amps: 900 volts
- f. (10 x 20 MS wave).

Install the arrestor on the line side of the 50 Amp fuse (where furnished), otherwise on the line side of the main circuit breaker.

2. Provide Circuit Breakers of high-magnetic trip type suitable for the cabinet as plans specify, with atmospheric temperature range of from -20° to +120° F (-30° to +50° C). Provide each circuit breaker of the size Table 1324.F.2 specifies, and have a manual switch for on-off and reset operation.

3. Provide Common Neutral Terminal Bus of solid copper or brass of the tubular screw type sized for No. 4 to No. 14 gauge wires. Make the number of poles required Table 1324.F.2 specifies.

4. Make Terminal Strips the barrier type rated for a minimum of 600 volts insulation. Provide terminal poles rated a minimum of 30 amps and tubular screw type with pressure plate sized for from one to five each No. 14 gauge wires. Make number of poles required as Table 1324.F.2 specifies.

5. Provide a Panel Board and/or shelf constructed of minimum 1/4 inch (6 mm) rigid noncombustible, high insulated (minimum 600 volts), moisture resistant material.

6. Furnish a Relay Fuse, panel mounted type with socket and cap. Provide fuses of glass tube type, 125 volt (unless Table 1324.F.2 indicates otherwise), slow blow, dual element.

7. Provide Load Relays of DPDT-Double break with a minimum life of two million cycles and operable within an ambient temperature range of from -67° to +140° F (-55° to +60° C).

Provide the coil rated for 120 volts with the pull-in voltage between 95 to 102 volts AC RMS. Provide contacts rated a minimum 15 amps incandescent lamp load at 120 volts and 30 amps resistive load at 240 volts AC RMS with an inrush current rating of at least 240 amps. Make contacts silver cadmium oxide with gold flash.

Make insulation between all elements and ground a minimum 1,500 volts AC RMS.

Construct relay sockets with knife switch type contacts 1/4 inch wide by 1/16 inch thick (6 mm wide by 1.5 mm) thick of cadmium-plated phosphor bronze. Make insulation between all contacts and ground a minimum 1,200 volts AC RMS.

8. Provide Control Relays rated for continuous duty, double break with a minimum life of one million cycles and operable within an ambient temperature range of from -20° to +140° F (-30° to +60° C). Provide the coil rated for 120 volt service. Furnish contacts rated a minimum 5 amps inductive load at 120 volts ac. rms. and 10/5 amps resistive load at 120/240 volts ac. rms.

Make insulation between all elements and ground a minimum 500 volts.

Provide relays plastic encased and furnished with a commercially available octal (eight pin) keyed, high dielectric phenolic socket.

Furnish all interior cabinet wiring of the sizes and colors details show and of THW or THWN insulation rated for 600 volts.

Make all interior cabinet wiring not indicated on detail sheets THW or THWN and sized adequately for the fuse and/or breaker rating and color coded according to N.E.C.

E. Components for Reversible Lane Control Station Cabinets.

1. Load Center - Furnish one 20-amp circuit breaker for the Type I station. Furnish one 20-amp and one 15-amp circuit breaker for the Type II Station.

2. Provide a Heavy Duty Rotary Power Selector Switch two sections or decks, non-shortening five position, break before make. Furnish the contacts with a minimum make and break rating of five amps at 115 volts AC resistive load. Provide the insulated decks of steatite or ceramic rated for minimum of 600 volts between contacts and ground. Ensure that indexing between contacts is a minimum of 20 degrees to maximum of 36 degrees. Make the switch bushing mounted with pointer knob and install in an aluminum enclosure for surface mounting on panel board.

F. Components for Relay Stations Only.

1. Provide a chassis with cover at least 11 inches wide by 17 inches long by two inches deep (300 mm by 450 mm by 50 mm), 18 gauge zinc plated finished steel.

2. Ensure that relays meet the requirements for Paragraph D.8 control relays.

3. Provide a variable resistance element consisting of a 69 watt, 125 volt incandescent standard traffic signal lamp with porcelain cleat type receptacle.

Table 1324.F.1 Cabinet Types - Dimensions

Dimensions							
Cabinet Type	Height		Width		Depth		Notes
	Minimum	Maximum	Minimum	Maximum	Minimum	Maximum	
Type "P" Pole or Pedestal Mounted	21 inches (550 mm)	24 inches (600 mm)	14 inches (350 mm)	17 inches (450 mm)	12 inches (300 mm)	14 inches (350 mm)	Inside Dimensions
Type "PL" Pole or Pedestal Mounted	36 inches (900 mm)	42 inches (1,000 mm)	21 inches (525 mm)	24 inches (600 mm)	14 inches (350 mm)	16 inches (400 mm)	Outside Dimensions
Type "G" Ground Mounted	*46 inches (1,200 mm)	*50 inches (1,250 mm)	28 inches (700 mm)	32 inches (800 mm)	15-1/2 inches (400 mm)	20 inches (500 mm)	*Including Base

**Table 1324.F.2
Cabinet Applications - Components**

Specification Paragraph Reference	Components	Unit	Controller Installation		Sampling Detector or Counting Station			Reversible Lane Control Station	Relay Station	Multi-Speed Advisory Sign Control Station	School Flasher Time Control
	Cabinet Type		PL	G	P	PL	G	P	P	P	P
1	Lighting Arrestor	Each	1	1	1	1	1	1	1	1	
2	Circuit Breaker No. & Current Size	Number Size	2 30	2 30	1 15	1 15	1 15	2* 1 -15 & 1-20	1 15	2 15	2 15
3	Neutral Bus (Minimum) No. of Poles	Number of Poles	12	15	10	12	15	8	5	10	1
4	Terminal Strip No. of Poles (Minimum)	Number of Poles	40	50	20	30	40	11	30	20	4
5	Panel Board (Width x Height)	Inches (mm)						12 x 9 (300 x 230)			
	Shelf No. Required	No.		1	1	2	3			1**	
6	Relay Fuse (Amp Capacity)	Amp.						2 Each 2A 150V	5		
7	Load Relays	No.						2		3	
8	Control Relays	No.							11		Time Clock***

* **Note 1:** Furnish Load Center with main rating of 40 amps, surface mounted with cover.

** **Note 2:** Furnish where plans specify Detector Amplifier(s) with this cabinet.
Shelf is incidental to payment of cabinet.

*** **Note 3:** City will furnish time clock for school flasher time control.

G. General Information. The purpose of the relay station is to maintain an acceptable voltage level (i.e., above 105 volts) on the interconnecting cable by refreshing the line with new service at specified locations.

Where plans specify "controller installation" application, payment of this item includes procuring the specified controller equipment (dial units, panel board, relays, etc.) from the City and remounting controller equipment in the specified cabinet. This is in addition to the required components of this specification. The City will supervise, inspect and advise Contractor as to the methods and arrangement of installing the equipment in the cabinet.

Where other items refer to this specification for cabinet construction and components, City will make payment under that specified item.

1324.06 Method of Measurement. Measure photo-electric cells as a complete unit in place, including socket, mounting hardware and wiring to the disconnect device.

Measure street lighting relays as a complete unit in place, including enclosure, components and mounting hardware.

Measure lighting and traffic control disconnect devices as a complete unit in place including padlock, fuses and mounting hardware.

Measure traffic signal controller as a complete unit in place, including connections and mounting hardware.

Measure auxiliary traffic control cabinets as a complete unit in place, including all components per the application specified, wiring and mounting hardware.

Measure auxiliary control equipment as a unit installed, connected and tested.

1324.07 Basis of Payment. City will make payment at the Contract unit price bid per each item as specified and as full compensation for all labor, materials, tool, equipment and incidentals necessary for each item the Contractor furnishes complete, connected, tested and accepted.

Item	Unit	Description
1324	Each	Photo-electric cell
1324	Each	Street lighting relay
1324	Each	Street lighting controller, ___ amp
1324	Each	Safety switch, ___ amp
1324	Each	Traffic signal controller, Installation only
1324	Each	Traffic signal controller, Furnish and Installation
1324	Each	Reversible lane control station type ___
1324	Each	Relay station

1324	Each	Control cabinet, type ____ mounted (Installation only option)
1324	Each	School flasher time control

Item 1325 Street Lighting Luminaires

1325.01 Luminaires.

A. General. Install luminaires of the type the plans specify and consisting of a complete lighting device, including housing, supporting hardware, reflector (as plans require in the specified type) refractor, socket, lamp, integral ballast (or where plans specify remote ballast), disconnection devices, terminal block for external wiring connections, photo-electric cell receptacle and incidentals as required. Provide the luminaire to be capable of operating the specified lamp in a completely sealed optical system (as required in the specified type) at the line voltage specified. The luminaire to provide the ANSI-IES Type distribution and cut off as specified.

The light source for the luminaire needs to be specified.

B. Luminaire Types.

- 1. Standard Roadway Type:** indicates a cobra head style housing designed for mounting on bracket or mast arms.
- 2. Underpass Type:** indicates a "wallpack" type housing designed for wall mounting.
- 3. Post Top Mounted Type:** indicates a decorative "colonial" or "modern" style luminaire for post top mounting.
- 4. Spherical Roadway Type:** indicates a decorative, classic, spherical shaped fixture resembling an "eye ball" for use with high (40 foot [12 m] or more) mounting heights and mounted on short slip-fitter arms.

C. Interchangeability. The refractor interchanges with the "standard" refractor of the same wattage and type luminaire. "Standard" refractors are manufactured by the General Electric Company, Westinghouse Electric Corporation, Holophane Company, McGraw-Edison Company, and J. H. Spaulding Company.

D. Supply Voltage. The luminaire operates as specifications require herein when the primary voltage has the specified nominal value, or is within tolerances the specified ballast requires. The primary voltage is normally 240 volts, unless otherwise specifications indicate otherwise, for all luminaire types except the spherical roadway type, which is 120 or 240 volts or multitap as plans specify.

E. Housing. Provide luminaire enclosures that conform to the construction and material specified herein for the type luminaire plans specify.

1. Standard Roadway Type. These are luminaires of cast aluminum with natural finish or a painted finish in light gray. The housing for the luminaire has a two or three piece

design consisting of the upper housing and a refractor holding lower door. Where the luminaire is of a three piece design, the third piece has a lower access door for access to internal components independent of the refractor door and is located to the rear of the refractor door toward the house side. Ensure that lower door assemblies hinge away from the upper half on the house end.

Ensure that the lower door assemblies include latching mechanisms located on the street side and closeable with one hand.

Ensure that the refractor holding door permits easy removal of the refractor without the use of tools and has a safety catch to prevent accidental removal.

Provide an access door for access to internal components or mount the components on the door.

Make the slipfitter adjustable to fit pipe brackets from 1-1/4 inch to two-inch pipe (30 mm to 50 mm) brackets. Ensure that the slipfitter permits an adjustment in the vertical plane of plus or minus 5 degrees and the luminaire has a slipfitter stop which allows an engagement of at least 4-1/2 inches (115 mm) of the bracket arm.

2. Underpass Luminaire. Install housing for the underpass type luminaire as cast aluminum with natural finish or a painted finish in light gray; provide with conduit mounting holes for wire entry and secure to a wall or vertical surface with two each 3/8 inch (10 mm) bolts through the rear of the fixture. Ensure the fixture opens easily with a quick snap hinged ring or approved latching device. Protect the refractor by means of an approved guard or shield.

3. Post Top Luminaire. Ensure that housing for the post top mounted type luminaire is cast aluminum with a slip-fitter suitable for a three-inch (75 mm) O.D. tenon, unless plans specify otherwise. Provide three sets of screws or two bolts to facilitate leveling and securing the fixture on the pole. Hinge the luminaire on one side (colonial style) and secure with a captive screw on the opposite side. Where plans call for the modern style luminaire, use a captive hand nut to allow easy (no-tool) assembly and disassembly of the canopy.

Paint the luminaires black, pole green or other (per Item 1317) as plans indicate.

4. Spherical Roadway Luminaire. Make one piece seamless spun aluminum housing for the semi-spherical roadway type luminaire. Luminaire size varies by location. Furnish fixtures for installation in the downtown core approximately 26 inches (660 mm) in diameter and 17-1/2 inches (445 mm) high with a 750 watt metal halide light source. Provide Spaulding number WN3-A-P75-H3F-Q-CC or approved equal.

Furnish fixtures for installation in the Downtown perimeter (frame) approximately 22 inches (560 mm) in diameter and 14 inches (356 mm) high with a 400 watt metal halide light source. Provide Gardco number MA22-1-4X-400PSMH-QUAD-SC or approved equal.

Construct door of formed aluminum with clear flat tempered glass lens. Provide door that is fully gasketed and hinged to housing. All access hardware and screws are to be captive variety.

Furnish segmented anodized aluminum reflector capable of providing IES Type III light distribution for horizontal lamp orientation.

Incorporate between the bottom of the housing and the reflector portion of the optical system a low brightness baffle designed to minimize visibility of the light source from a horizontal distance greater than five mounting heights from the luminaire.

Make the housing support an extruded ten inches (254 mm) aluminum arm and 5RPA adapter. Firmly support complete luminaire and all its parts. Provide a mechanical adjustment to allow about the axis adjustment as well as vertical adjustment of up to 25 degrees. Completely seal the optical system.

Make all parts of the luminaire assembly weatherproof and capable of withstanding winds to 100 mph (160 kph).

5. Painting. Ensure that all exposed parts of luminaire are factory painted. Paint aluminum parts after anodizing.

a. Prime coat (submarine epoxy) – 4.6 wet mils (117 μm) thickness.

b. Intermediate coat – 7.0 wet mils (178 μm) thickness.

c. Final coat - Cincinnati MALT Pole Beige: Federal Standard Color 20372; or Foy-Johnson No. 29842 or equal by Porter, Wilson, or Pratt & Lambert - spread at rate of 300 $\text{ft}^2/\text{gallon}$ (7 m^2/L) or 5.3 wet mils (135 μm) thickness.

6. Make all type housings complete with components weatherproof, and mount all components including ballast internally unless otherwise specified. Ensure that the refractor, reflector and ballast system are easily removable. Ensure that the luminaire will withstand winds to 100 miles per hour (160 kph).

F. Reflector. Make the reflector readily detachable and removable and in spherical roadway type luminaires supported from its top, the reflector to consist either of pressed prismatic heat resisting glass with sealed and spun-on cover, or a spun aluminum diffused material with aluminum-coated (Alzak) finish. Ensure that the inner surface of the reflector is smooth, non-porous and easily cleaned.

Provide reflectors in all type luminaires except the post top mounted type.

G. Refractor. Make the refractor of heat and high impact resistant material of polycarbonate or a heat resistant borosilicate glass or approved equal and design it so that it can be installed only in the correct position in the refractor holder. Ensure that glass is well annealed and free from imperfections and striations.

Ensure that refractors for lamp of 250 watts or greater are constructed from heat resistant borasilicate glass or approved equal.

Ensure that the refractor is embossed to clearly indicate the street side and house side prisms.

Ensure that panels used with the colonial style post top mounted luminaire are white frosted.

Ensure that for spherical roadway type luminaires the bottom of the reflector is covered with a gasketed door containing a large refractor.

Type A Refractor: Make this a clear non-prismatic crystal glass for resisting breakage due to heat and mechanical stresses, well annealed and free from imperfections and striations. When in place and with the luminaire operating, the window should withstand a heavy sprinkling of ice water.

Type B Refractor: Make this a convex refractor with prisms meeting the requirements previously specified for refractor material of polycarbonate or glass.

H. Optical seal. This consists of compressible, heat resisting nonlatex, resilient gasketing material to seal out insects, dust, dirt and water effectively. The material must provide a complete sealing of the optical system at the point of entry of the socket into the reflector and between the reflector and the refractor. Make the gasket readily removable from the reflector.

Post top mounted type luminaires do not require an optical seal.

Provide standard roadway type luminaires with a carbon filter to eliminate accumulation of dirt and other foreign matter in the optical system.

I. Ballast. Furnish each luminaire with a single-lamp ballast. Mount the ballast internally unless plans specify otherwise. Provide a ballast with a high power factor of at least 90 percent. Ensure the ballast is capable of starting lamps in temperatures as low as -20° F (-30° C), and is rated for the circuit voltage and size of lamp plans specify.

Attach a nameplate identifying the electrical and mechanical characteristics of the ballast as a permanent part of the ballast.

Provide a ballast that has the wattage rating of the lamp specified and the weight of the internal ballast that does not exceed 30 pounds (14 kg). Allowable ballast losses listed in Table 1326.02 are considered average losses.

Where multi-tap or "quad" voltage ballasts are specified, supply ballasts internally wired for connection to the circuit voltage specified in the Contract and plan sheets.

Where plans specify, furnish epoxy encapsulated external ballasts, suitable for aerial, post top, pole base or vault installation and enclose them in a corrosion free weathertight

aluminum tank. Provide the ballast with a minimum of 12 inch (300 mm) long leads for external connection and lead wiring insulation rated for such service.

In addition to the foregoing general characteristics, provide ballasts that conform to the following characteristics for the type specified:

Ballasts for Mercury Vapor Lamps. Furnish and install the constant wattage or regulator type with separate primary and secondary windings delivering rated lamp current at circuit voltage variations of plus or minus 13 percent.

Ensure that the regulation output of lamp wattage does not exceed a total range of four percent for lamps rated 400 watts or less or six percent for lamps rated in excess of 400 watts.

Ballasts for Metal Halide Lamps. Furnish and install the peak load auto regulator type delivering rated lamp watts within plus or minus ten percent with plus or minus ten percent variations in applied voltage.

Ballasts for High Pressure Sodium Lamps. Furnish and install the regulator type with isolated primary and secondary windings for up through 400 watts. For 1,000 watt lamps, make ballasts the auto regulator type. In both cases the ballast delivers rated lamp current at circuit voltage variations of plus or minus ten percent.

Include starter components in ballasts. Make the starter component of solid state devices capable of withstanding ambient temperatures of 212° F (100° C). Make the starter to provide timed pulsing with sufficient follow-through current to completely ionize and start all lamps meeting published ANSI standards. Provide field replaceable starters completely interchangeable with no adjustment necessary for proper operation. They will have push on-type electrical terminations to provide good electrical and mechanical integrity and ease of replacement.

Treat the starter circuit board in an approved manner to provide a water and contaminant resistant coating. Ensure that the starter circuit-ballast combination is designed to consistently provide the following parameters:

1. Lamp wattage must be maintained within the trapezoid recommended by lamp manufacturers within the full rated input voltage range.
2. Amplitude of the pulse 2,500 volts minimum and 4,000 volts maximum. Operation of the pulse at spike voltage levels near minimum is desirable.
3. Minimum pulse width one microsecond at 2,250 volts, applied within 20 electrical degrees of the peak of the open circuit voltage wave, with a minimum repetition rate of one pulse per cycle of the 60 cycle wave.
4. Ensure that pulses are present when ballast is correctly wired when applying nominal voltage less 15 percent to the ballast windings.

5. Protect the high pressure sodium ballast, including starting aids, against normal lamp failure modes. Ensure that ballast operates with the lamp in an open or short circuit condition for six months without significant loss of ballast life. Ensure that the luminaire Manufacturer supplies ballast electrical data and lamp operating volt-watt traces for nominal and plus or minus ten percent rated line voltage to verify ballast performance and compliance with ANSI lamp specifications, for the rated life of the lamp.

J. Socket. Make the socket of a rugged high grade porcelain body with a mogul screw shell type base and rated for 600 volts (5,000 volt impulse for high pressure sodium lamps). Make the socket shell from nickel or nickel plate and having lamp grips to prevent the lamp from loosening. Ensure that when the lamp is in its normal operating position, the porcelain of the socket body covers all metal on the lamp base.

Make the socket adjustable in standard roadway type luminaires to provide other ANSI-IES type distributions. Provide a means of identification to associate each lamp position with each distribution. For socket adjustment, provide positive positioning by means of index holes, lugs or notches. The City will not accept slots with infinite settings. In underpass type luminaires make the socket position to be adjustable to give a 60 or 70 degree beam angle.

K. Lamp. Furnish a lamp with each luminaire of the type source and wattage specified in accordance with Item 1326.

Make lamps for the spherical roadway type luminaire of 1,000 watt Metal Halide.

L. Fastening, Wiring and Disconnecting Devices. Make all required hardware of approved non-corrosive material.

Use slotted head type fastening devices in standard roadway type luminaires.

Disconnect devices are designed to prevent electrical hazard to personnel servicing the fixture before approval by the City.

Connect the end of each conductor not connected to the socket to a terminal block by spade terminals or other suitable removable connectors.

Provide a terminal block with enough terminals for incoming service wires, ground wire for safety, socket connections, and ballast connections for both internal and remote ballast location. Make the terminal block easily accessible.

M. Wiring Diagram. Provide a schematic wiring diagram and attach it to the interior of the luminaire in a permanent manner.

N. Photometric Data. Ensure that the luminaire reflector and refractor give an IES distribution for the type luminaire specified unless otherwise.

1. Provide a standard roadway type. Medium-Semi cutoff and Type II or Type III as plans specify.

2. Provide an underpass type designed to direct all useful light below the normal viewing angle, resulting in high utilization of lumen output.

3. Post top mounted type (Type V unless plans specify otherwise)

4. Spherical roadway type (Type A refractor)
(Type B refractor)

Spherical roadway type luminaire photometrics:

With Type A (Clear) Refractor - Beam Spread = 122° vert. x 122° horiz.
Max candle power = 31,751

With Type B (Prism) Refractor - Beam Spread = 134° vert. x 167° horiz.
Max. candle power = 17,121

O. Photo-Electric Receptacle. Provide all standard roadway and post top mounted type luminaires with a receptacle with shorting cap for City-wide interchangeability purposes. Ensure that the receptacle meets EEI-NEMA standards and is a twist-lock type. Wire the receptacle for 120 volts and provided it with an easy adjustment for orienting to the north. Maintain weather sealing, moisture and dust proofing.

P. Weight and Area. Make luminaires complete and ready for service to comply with the following weight and projected area requirements:

Table 1325

	Luminaire Type	Size by Wattage	Maximum Projected Area in ft² (m²)	Maximum Weight in Pounds (kg)
1	Standard Roadway Type	100-175	1.6 (0.15)	35 (16)
		200-400	1.6 (0.15)	55 (25)
		700-1,000	2.5 (0.25)	60 (27)
2	Underpass Type (Not Applicable)			
3	Post Top Mounted Type (Colonial and Modern Types)	70-175	2.0 (0.20)	35 (16)
		200-400	3.8 (0.35)	55 (25)
4	Spherical Roadway Type	up to 1,000	4.4 (0.40)	50 (23)

Q. Installation. Install luminaires mounted on poles to adjust vertically and horizontally to provide the required mounting height and specified alignment with the roadway. Where the profile grade exceeds 4 percent, orient the luminaires so that the vertical axis of the luminaire is perpendicular to the longitudinal centerline of the roadway at that location.

Mount luminaires on walls level. Where mounting more than one luminaire on the same wall, mount them at the same elevation so as to present a straight line appearance.

Mount luminaires mounted on post tops level and in line with the vertical axis of the post.

1325.02 Method of Measurement. Measure luminaires as a complete unit in place, including lamp and all components and testing.

1325.03 Basis of Payment. The City will make payment at the Contract unit price bid for each luminaire, by type, and as full compensation for all labor, materials, tools, equipment, and incidentals necessary to furnish and install each luminaire complete, connected, tested and accepted.

Item	Unit	Description
1325	Each	Luminaire, ___ watt, ___ +volt, ___ (light source), ___ type.

Item 1326 Lamps

1326.01 Traffic Signal Lamps. Include a lamp in each traffic signal optical section that conforms to the ITE specification "A Standard for Traffic Signal Lamps", with the following exceptions and qualifications:

- A.** Furnish and install brass screw bases with a rotational adjustment feature.
- B.** Install lamps with the base rotated so the open portion of the lamp filament is in an upward position.
- C.** Provide lamps with a minimum rated life of 8,000 hours with the exception of 135 and 150-watt lamps which have a minimum rated life of 6,000 hours.
- D.** Provide 60-, 90- and 135-watt lamps that are Krypton gas filled.

Provide lamps for the respective signal equipment in accordance with Table 1326.01.

Include the cost of furnishing and installing lamps in the bid price of each signal item.

**Table 1326.01
Traffic Signal Lamps**

	Size/Type	Watts	Rated Volts	Light Center	Industrial Lamp Number	Rated Life (Hours)
Vehicular Traffic Signal Heads	8 Inch Sections	60	120/125	2-7/16" (62 mm)	60AT19 or 60A19TS Clear	8,000
	12 Inch Arrow Indications	90	120/125	3" (75 mm)	90AT19 or 90A19/1/TS Clear	8,000
	12 Inch Sections	135	120/125	3" (75 mm)	135AT19 or 135A19TS Clear	6,000
Pedestrian Signal Heads	12 Inch 2 Section Type A2	90	120/125	3" (75 mm)	90AT19 or 90A19/1/TS Clear	8,000
	18 Inch 3 Line Type D2	60	120/125	2-7/16" (62 mm)	60AT19 or 60A19TS Clear	8,000
Optically Programmed Signal Head	12 Inch Sections	150	115		M-123/131 Sealed Beam	6,000

**Include the cost of furnishing and installing lamps
in the bid price of each signal item**

1326.02 Lamps for Street Lighting Luminaires. Furnish a lamp with each luminaire that conforms to ANSI Specifications C-78 for all HID (Hi Intensity Discharge) type lamps. Make all lamps first line, high quality having heat resistance clear glass envelopes, except make all mercury vapor lamps the deluxe white type.

Where plans specify incandescent type lamps, install lamps meeting the requirements of Federal Specification number W-L-101.

Ensure that HID lamps by size conform to the following characteristics of the Table 1326.02.

Provide high pressure sodium lamps with a ceramic arc tube interior. Ensure that lumen output at end of economic life (67 percent of rated life) is not less than 80 percent of initial

lumen rating. Ensure that rated life for high pressure sodium lamps is at ten hours start, and all high pressure sodium lamps are 100 volt lamps. Initial lumens shown are for horizontal burning.

All performance data in Table 1326.02 reflect normal operating conditions.

Ensure that metal halide lamps have a quartz arc tube interior. Provide lamps that have lumen output at the end of their economic life not less than 65 percent of the initial lumen rating.

The rated life for metal halide lamps is at 10 hours start.

Lamp Warm-Up Time to 80% Light:

Mercury Vaporfive to seven minutes.
 High Pressure Sodium.....three to four minutes.
 Metal Halide.....three to five minutes.

Lamp Re-Strike Time:

Mercury Vaporthree to six minutes.
 High Pressure Sodium.....one minute.
 Metal Halide.....ten to 15 minutes.

**Table 1326.02
 High Intensity Discharge Lamps and Ballast Losses**

Lamps					Ballasts
Type	Lamps (Watts)	Industrial Lamp No. by ANSI Code and Spec. No.	Rated Horizontal Initial Lumens	Rated Life (Hours)	Loss (Watts)
Mercury Vapor	100	H38JA-100/DX-C78.1300	4,000	24,000	27
	175	H39KC-175/DX-C78.1308H	8,150	24,000	35
	250	H37KC-250/DX-C78.1301	11,150	24,000	42
	400	H33GL-400/DX-C78.1305	21,500	24,000	60
High Pressure Sodium	70	S62	5,800	20,000	35
	100	S54	9,500	20,000	44
	150	S55 (55 Volt)	16,000	24,000	54
	150	S56 (100 Volt)	16,000	24,000	54
	200	S66	22,000	24,000	54
	250	S50	27,000	24,000	65
	310	S67	37,000	24,000	70
	400	S51	50,000	24,000	85
	1,000	S52	140,000	24,000	90

Metal Halide	70	M98	5,000	5,000	16
	100	M90	8,500	10,000	20
	175	M57	14,000	7,500	35
	250	M58	19,500	7,500	44
	400	M59	32,000	15,000	62
	1,000	M47	100,000	10,000	90

Item 1327 Traffic Signals

1327.01 Vehicular Traffic Signal Heads.

A. General. Provide signal heads that are in conformance with ANSI No. D10.1 or the latest revised ITE standard for "Adjustable Face Vehicle Traffic Control Signal Heads", whichever is more recent, except as noted otherwise herein. This specification also provides the minimum performance requirements for 12 inch (300 mm), eight inch (200 mm) and 12 inch (300 mm) arrow traffic signal modules. It is not intended to impose restrictions upon specific designs and material that conform to the purpose and intent of this specification. The specification refers to definitions and practices described in "Vehicle Traffic Control Signal Heads" published in the Equipment and Material Standards of the Institute of Transportation Engineers, referred to in this document as "VTCSH". The multiple LED light source should be the latest technology available on the market. Utilize LED's manufactured with AllnGaP technology for red, amber and yellow indications or InGaN for green indications.

All LED traffic signal lamps must meet or exceed all the requirements of the current Institute of Transportation Engineers' 9ITE PUBLICATION ST-011B Pedestrian Traffic Control Signal Indications (PTCSI) and the current ITE specifications for Vehicle Traffic Control Signal heads (VTCSH), Part 2: Light Emitting Diode (LED) Vehicle Traffic Signal Module, unless otherwise stated in the specifications herein.

Gelcore, Dialight or pre-approved equal LED traffic signal lamps on the current ODOT QPL are acceptable as well as pixilated described herein. Provide only new LED lamps of the latest model currently in production. Equipment no longer being manufactured will not be accepted even if it meets the following specifications.

Furnish the signal heads in the arrangements shown on the plans and details.

B. Design. Provide signal assemblies consisting of eight inch or 12 inch (200 mm or 300 mm) units rigidly fastened together in various combinations as specified. Ensure that the signal assembly is made in accordance with the Manual of Uniform Traffic Control Devices (MUTCD). Assemble the sections in such a manner as to prevent dirt or moisture entering into the unit, or the possibility of rotation or misalignment. Construct signals in such a way as to allow assembly or disassembly of individual sections with the aid of standard tools.

Make traffic signals capable of both vertical and horizontal mounting. Ensure that each signal section, electrical unit and optical unit is interchangeable with other signal heads of the same Manufacturer.

C. Housing. Provide the signal head, including the door and visor, of polycarbonate material, or as otherwise specified. If plans specify no material, furnish signal heads in any of the above approved materials. Provide all parts, including hardware, of non-corrosive materials.

Normally, make eight inch signal head size ten inch by ten inch (250mm x 250mm) and 12 inch signal head size 14 inch by 14 inch (356 mm x 356 mm). The City will not accept signal heads exceeding these dimensions by more than 1/2 inch (12 mm).

Polycarbonate Construction. Make the housing of each signal section one-piece virgin ultra-violet stabilized polycarbonate resin black in color. Make the unit by injection molding and have a minimum wall thickness of 0.100 inches (2.5 mm). Equip all sections with metal inserts in the housing to prevent stripping of threads in areas that require constant removal of fastening devices (such as the door) on a regular maintenance basis. Connect no electrical wiring or terminal block to the housing by use of self-taping screws in such a manner as to allow the connections to loosen if terminal generates heat resistance. Make the polycarbonate material strong enough to withstand a 70 foot-pound (95 Nm) impact without fracture or permanent deformation.

Alternate Construction (Aluminum). Where specified, construct the housing of each signal section of one piece dense cast aluminum.

Housing General. Make the area around the upper and lower openings ribbed or reinforced so as to be capable of handling breaking strengths that the ITE Standards (Section 3.01-6) specify.

Provide each housing with serrated round bossed openings at the top and bottom so that it rotates about a vertical line and is capable of being securely fastened at increments of no more than seven degrees.

After assembling the unit, drill a 3/8 inch (10 mm) hole for water drainage.

D. Door. Attach the door to the housing with stainless steel hinge pins and design it in a manner that does not allow the door to become accidentally detached when mounted in either a vertical or horizontal position. Design the door's locking device so that technicians do not require tools to open and close the door. Make the color of the door yellow.

E. Visor. Make visors as one molded piece in the "Tunnel" style, NOT the angle type. Make the visor with a longitudinal rectangular cutout in the bottom. Tilt the visor at an eight degree angle and equip it with four lugs, each with stainless steel or brass machine screws to hold it in place. Locate the lugs to permit rotating of the visor 90 and 180 degrees relative to the door. Securely fasten the visor to the door with the lugs, but make it removable with simple tools. Make the visor color black.

The length of the visor will vary depending on the signal specified on the plan sheets.

1. For eight inch (200 mm) traffic signal heads, make the length seven to eight inches (175 mm to 200 mm).

2. For 12 inch (300 mm) traffic signal heads, make the length ten to 12 inches (250 mm to 300 mm).

F. Optical Unit. Equip each signal section with a neoprene or other approved resilient gasket, adequately sealing the lens to the door to assure a dust and moisture tight optical system. Install units in the optical system in a manner permitting easy replacement.

1. Reflector. Make the reflector of the Alzak process, or approved equal, highly polished specular finished aluminum type. Make it easily replaceable without replacing the reflector holder. Make the reflector holder easily replaceable and hinged to the signal housing to allow easy access for replacing lamp.

2. Lamps. Lamps will come with each signal section. Table 1326.01 indicates size and characteristics.

3. Lamp Receptacle. Make the lamp receptacle of a heat resisting material and designed to properly position a medium screw base traffic signal lamp. Provide the receptacle with an antivibration device and a positive locking device so that the socket will not turn when installing the lamp. Make provision on the receptacle and/or the reflector to permit rotation of the lamps so that the leadin wires are in the upward position, and to secure the lamp in this position. Make the lamp receptacle the fixed pefocus type designed for a lamp light center length of 2-7/16 inches (62 mm) for eight inch (200 mm) signals and three inch (75 mm) for 12 inch (300 mm) signals.

4.

Lens, Incandescent. All lenses are the circular convex type in eight inch (200 mm) or the 12 inch (300 mm) size. The "ARROW" lenses are always 12 inch in size. Equip each 12 inch (300 mm) signal section with the wide angle type lens. Ensure that lenses are fabricated of durable polycarbonate impact-resistant plastic, or approved equal. Provide a neoprene gasket between the reflector and the lens to assure a dust and weatherproof seal between these components when the door is closed and latched to the housing. Fasten the lens to the door by use of machine screws and lugs and make it removable with simple tools. Ensure that all lenses conform to ITE and ANSI standards.

G. Physical and Mechanical Requirements, LED Optical Units. Provide LED traffic signal modules with expanded view (the module) designed as retrofit replacements for existing signal lamps that do not require special tools for installation. Provide retrofit replacement LED modules that fit into existing traffic signal housings built to VTCSH standard without modification to the housing.

Provide retrofit replacement LED signal modules that can be installed by simply removing the following existing components: lens, lamp module, gaskets. Provide replacement modules that fit securely and are weathertight in the existing housing and connect directly to existing electrical wiring.

Removal of the existing incandescent lamp reflector is optional. Provide LED optical units that retrofit to Peek Traffic/TCT, NO TCPSS83K300P, Peek Traffic/TCT NO ESS83K300P or LFE

TRAFFIC CONTROL DIVISION, Eagle Signal No. SIG. 103A1111BYB or LFE TRAFFIC CONTROL DIVISION, Eagle Signal No. SIG. 130A1111BYB or approved equal traffic signal housing units.

1. LED Signal Module.

- a. Tinting (Optional) – Tint lens or use transparent film or materials with similar characteristics.
- b. The LED module lens may be a replaceable part without the need to replace the complete LED module.
- c. The configuration of the LED arrow is illustrated in Figure 1327.01.

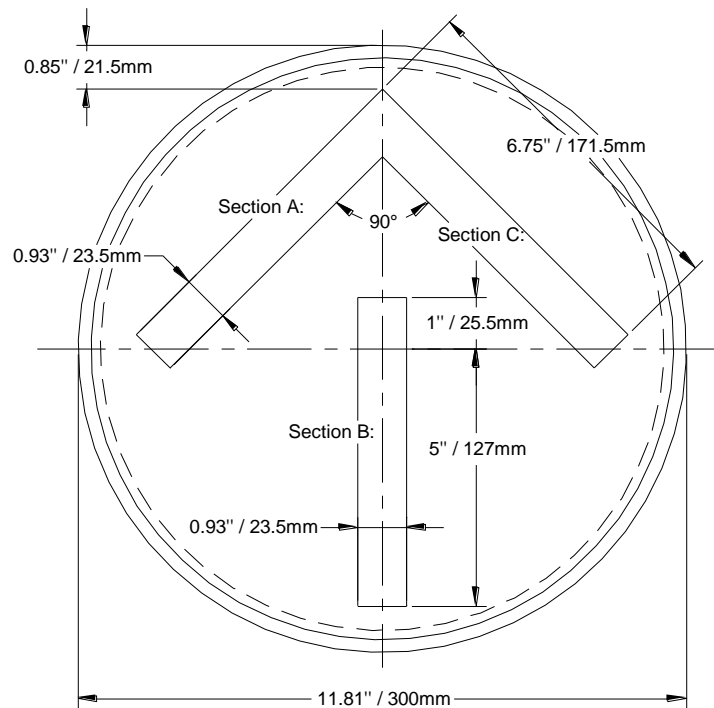

Figure 1327.01 – LED Arrow Configuration

2. Environmental Requirements.

- a. Provide LED module rated for use in the ambient operating temperature range of -40°F to $+165^{\circ}\text{F}$ (-40°C to $+74^{\circ}\text{C}$).
- b. Protect the LED module against dust and moisture intrusion as per NEMA Standard 250-1991 requirements for Type 4 enclosures. Protect all internal LED, electronic and electrical components.
- c. Provide LED signal module lenses that are UV stabilized.

d. Provide LED signal module lenses that are smooth on the outside and specifically designed to reduce sun reflections (sun phantoms).

e. Supply the LED module with an installed gasket.

3. Construction.

a. Provide LED modules that are single, self-contained devices, not requiring on-site assembly for installation into existing traffic signal housings. The power supply must fit and mount inside the LED module.

b. Design the assembly and manufacturing processes for the LED assembly to assure all internal LED and electronic components are adequately supported to withstand mechanical shock and vibration from high winds and other sources.

4. Materials.

a. Conform to applicable ASTM specifications for materials used in the lens and LED module construction/manufacture.

b. Construct enclosures containing the power supply and electronic components of the LED module of UL94VO flame retardant materials. The lens of the LED module is excluded from this requirement.

5. Module Identification.

a. Identify each LED module on the back side with the Manufacturer's name and the unit's serial number.

b. Identify the following operating characteristics: nominal operating voltage, power consumption, and volt-amperes.

c. Provide all LED modules with prominent and permanent vertical indexing indicators (i.e., Up Arrow or the word "Up" or "Top") for correct indexing and orientation inside the signal housing.

H. Photometric Requirements – LED Optical Units.

1. Luminous Intensity and Distribution.

a. Furnish LED modules that provide the maintained minimum luminous intensity values shown in Tables 1327.A, B and C throughout the warranty period under the operating conditions defined in sections 1327.01.G.2.a and 1327.01.N.4.b.

b. Furnish LED modules that provide measured chromaticity coordinates between 500 nm and 650 nm when operating within the temperature range specified and conform to the chromaticity requirements of Section 8.04 and Figure 1 of the VTCSH standard.

c. Furnish LED modules whose optical assemblies diffuse the light output and provide uniform illumination across the entire surface of circular lenses. Provide LED modules whose individual LED's are not visible to the observer of indications displayed.

Table 1327.A – Maintained Minimum Luminous Intensity for Expanded View LED Signal Modules
– 12-Inch Signal

Vertical Angle (Degrees)	Horizontal Angle (Left & Right) (Degrees)	12-Inch Signal		
		Red	Yellow	Green
-17.5	17.5	3	7	7
	2.5	10	20	20
-12.5	17.5	14	27	27
	2.5	20	41	41
-7.5	17.5	20	41	41
	2.5	54	108	108
-2.5	17.5	58	115	115
	2.5	220	441	441
+2.5	2.5	339	678	678
	7.5	251	501	501
	12.5	141	283	283
	17.5	77	154	154
+7.5	2.5	226	452	452
	7.5	202	404	404
	12.5	145	291	291
	17.5	89	178	178
	22.5	38	77	77
+12.5	27.5	16	32	32
	2.5	50	101	101
	7.5	48	97	97
	12.5	44	89	89
	17.5	34	69	69
	22.5	22	44	44
+17.5	27.5	16	32	32
	2.5	22	44	44
	7.5	22	44	44
	12.5	22	44	44
	17.5	22	44	44
	22.5	20	41	41
+22.5	27.5	16	32	32
	2.5	10	20	20
	17.5	7	14	14

Table 1327.B – Maintained Minimum Luminous Intensity for Expanded View LED Signal Modules
– 8-Inch Signal

Vertical Angle Down (Degrees)	Horizontal Angle (Left & Right) (Degrees)	8-Inch Signal		
		Red	Yellow	Green
2.5	2.5	133	267	267
	7.5	97	194	194
	12.5	57	113	113
	17.5	25	48	48
7.5	2.5	101	202	202
	7.5	89	178	178
	12.5	65	129	129
	17.5	41	81	81
	22.5	18	37	37
	27.5	10	20	20
12.5	2.5	37	73	73
	7.5	32	65	65
	12.5	28	57	57
	17.5	20	41	41
	22.5	12	25	25
	27.5	9	16	16
17.5	2.5	16	32	32
	7.5	14	28	28
	12.5	10	20	20
	17.5	9	16	16
	22.5	6	12	12
	27.5	4	9	9

Table 1327.C – Maintained Minimum Luminous Intensity for the LED Vehicle Arrow Traffic Signal Modules

Vertical Down (Degrees)	Horizontal Angle (Left & Right) (Degrees)	12-Inch Signal		
		Red	Yellow	Green
2.5	2.5	60	150	90
	7.5	44	110	66
	12.5	25	62	38
	17.5	14	35	21
7.5	2.5	40	100	60
	7.5	36	90	54
	12.5	26	65	39
	17.5	16	40	24
	22.5	7	17	11
	27.5	3	7	4
12.5	2.5	9	23	14
	7.5	9	22	14
	12.5	8	20	12
	17.5	6	15	9
	22.5	4	10	6
	27.5	3	7	4
17.5	2.5	4	10	6
	7.5	4	10	6
	12.5	4	10	6
	17.5	4	9	6
	22.5	4	8	5
	27.5	3	7	4

2. Chromaticity.

a. Provide LED modules with measured chromaticity coordinates between 500 and 650 nm, conforming to the chromaticity requirements of section 8.04 and Figure 1 of the VTCSH standard.

I. Electrical Requirements – LED Optical Units.

1. General.

Furnish wiring and terminal blocks that meet the requirements of section 13.02 of the VTCSH Standard. Provide two secured, color coded, 36 inch (914 mm) long 600 volt, 20 AWG minimum jacketed wires, conforming to the NEC, rated for service at +220° F (+105° C) for electrical connection.

2. 15.2 Voltage Range.

a. Furnish LED modules capable of operating from a 60 ± 3 cycle AC line power over a voltage range from 80 to 135 volts AC RMS. The current draw must be sufficient to ensure compatibility and proper triggering and operations of load current switches and conflict monitors in the signal controller that the procuring traffic authority customer has in use.

b. Nominal operating voltage for all measurements is $120 \pm$ volts RMS.

c. Furnish units whose luminous intensity is not affected by more than \pm ten percent by fluctuations in line voltage over the range of 80 to 135 volts AC.

d. Furnish LED circuitry that prevents flickering at less than 100 Hz over the voltage range specified in Section 15.2.1.

e. Low Voltage Turn Off. Furnish modules that do not illuminate when the applied voltage is less than 45 volts AC. Test for this condition by first fully illuminating the unit at the nominal operating voltage. Then, reduce the applied voltage to the point that there is no illumination. That point must be greater than 45 volts AC. The same requirement applies to raising the voltage from 0 to 45 volts AC with no visible illumination.

f. Turn-On and Turn-Off Time. Furnish modules that reach 90 percent of their full illumination (turn-on) within 100 msec (\pm 10 msec) after the application of the nominal operating voltage. Furnish modules that are not illuminated (turn-off) within 100 msec (\pm 10 msec) after the removal of the nominal operating voltage.

3. Transient Voltage Protection.

Furnish LED modules containing on-board circuitry that includes voltage surge protection to withstand high-repetition noise transients and low-repetition, high-energy transients as stated in Section 2.1.6, NEMA Standard TS-2, 1992.

4. LED Drive Circuitry.

a. Wire the individual LED light sources so that the catastrophic failure of one LED will result in the loss of the light from only that one LED.

b. Provide current regulated power supply.

5. Electronic Noise.

Provide LED modules and associated on-board circuitry that meets Federal Communication Commission (FCC) Title 47, SubPart B, Section 15 regulations concerning the emission of electronic noise.

6. Power Factor (PF) and AC Harmonics.

- a. Provide LED modules that have a power factor of 0.90 or greater when operated at nominal operating voltage and at 77° F (25° C).
- b. Provide LED signal modules that do not induce total harmonic distortion into an AC power line exceeding 20 percent at nominal operating voltage at 77° F (25° C).

7. Wattage.

Provide LED modules that are less than or equal to the base wattages shown below at 77° F (25° C).

Type	Wattage
12" (300 mm) Red Ball	10 or less
12" (300 mm) Yellow Ball	22 or less
12" (300 mm) Green Ball	14 or less
12" (300 mm) Yellow Arrow	10 or less
12" (300 mm) Green Arrow	7 or less
8" (200 mm) Red Ball	6 or less
12" (200 mm) Yellow Ball	14 or less
12" (200 mm) Green Ball	8 or less

J. Terminal Block. Equip the signal head assembly with a barrier type terminal block having five poles for three or four section signal heads and seven poles for five section signal heads. Terminate wiring from the lamp sockets and external cable connections at the terminal block.

Make the terminal block easily accessible and removable. Mount the terminal block to the interior of the signal assembly with approved nuts, bolt and washers. The City will not accept sheet metal screws.

K. Wiring. Make wiring of the signal head assembly color coded, No. 18 stranded copper fixture wire rated at 300° F (150° C), 300 volts, types PF, SF, or equal per Article 310-2(a) and 402 of NEC for incandescent units.

L. Color. Impregnate the color into the resin material to make the color of the polycarbonate signals permanent. The color is as follows:

- 1. The back and visors are black.
- 2. The front or doors are yellow.

M. Weight. The maximum weight of each signal head is as follows:

Product	Maximum Weight in Pounds (kg)
12 Inch (300 mm) Sections Polycarbonate Type	8 (3.5)
8 Inch (200 mm) Sections Polycarbonate Type	4 (1.8)
12 Inch (300 mm) Sections LED Type	10 (4.5)
8 Inch (200 mm) Sections LED Type	6 (2.7)

N. Quality Assurance for LED Optical Units.

1. General.

a. Quality Assurance Program. Manufacture LED modules in accordance with a Vendor quality assurance (QA) program. Furnish only products from Vendors whose QA programs include two types of quality assurance: (1) design quality assurance, and (2) production quality assurance. The production quality assurance must include statistically controlled routine tests to ensure minimum performance levels of LED modules built to meet this specification.

b. Record Keeping. Keep QA process and test result documentation on file for a minimum period of seven years.

c. Conformance. Do not label, advertise or sell LED module designs as conforming to this specification if they do not satisfy design qualification testing and the production quality assurance testing performance requirements of Sections 21.3 and 21.4

2. Manufacturer's Serial Numbers. Identify each LED module with the Manufacturer's serial number for warranty purposes.

3. Production Quality Assurance (QA) Testing. Test all new LED modules in accordance with the following Production Quality Assurance testing regimen prior to shipment. Reject any LED module that does not meet the requirements of these QA Tests. Maintain QA test results per the requirements of Section 21.1.2.

a. Module Burn-In. Energize all LED modules or the electronic circuitry sub-assemblies, including all LEDs for a minimum of 24 hours at 100 percent on-time duty cycle at an ambient temperature of +140° F (60° C).

b. Maintained Minimum Luminous Intensity. Test all LED modules for maintained minimum luminosity after burn-in. A single point measurement with a correlation to the intensity requirements of Tables 1, 2 or 3 in Section 14.0 may be used. Operate the LED modules at nominal operating voltage and at an ambient temperature of 77° F (25° C).

c. Power Factor. Test all LED modules for power factor after burn-in per the requirements of Section 15.6.1. A commercially available power factor meter may be used to perform this measurement.

d. Current. Measure all LED modules for current flow in amperes after burn-in. Compare the measured current values against current values resulting from design qualification measurements in Section 21.4.4.1. Reject LED modules exhibiting measured current values in excess of 120 percent of the design qualification current values.

e. Visual Inspection. Visually inspect all LED modules for any exterior physical damage or assembly anomalies.

4. Design Qualification Testing. Perform design qualification testing on new LED module designs, and when a major design change has been implemented on an existing design. The minimum sample quantity of LED modules must be as stated for each test. Failure to meet requirements of any of these tests will be cause for rejection.

Perform testing once every five years or when the module design or LED technology has been changed. Retain test data at the testing laboratory and at the LED module Manufacturer for a minimum period of five years.

a. Burn-in. Energize LED modules for a minimum of 24 hours, at 100 percent on-time duty cycle, in an ambient temperature of +140° F (60° C) before performing any design qualification testing.

b. Maintained Minimum Luminous Intensity.

I. After burn-in, test a random sample of six LED modules for maintained minimum luminous intensity at each of the 44 points indicated in Tables 1, 2 and 3 in Section 14.0. Take and record these measurements at an ambient temperature of 77° F (25° C) after the signal has been operated for 60 minutes.

II. After burn-in, test a random sample of six LED modules for maintained minimum luminous intensity. Mount signals to be tested in a temperature testing chamber so that the lensed portion of the signal is outside the chamber and all portions behind the lens are within the chamber at a temperature of 165° F (74° C). Maintain the air temperature in front of the lens of the signal lens at a minimum of (120° F (49° C) during all tests.

Test red and green LED modules for luminous output at 165° F (74° C). Allow the modules to achieve thermal equilibrium for 60 minutes, while the modules are energized at nominal operating voltage, at a 100% duty cycle. Take and record a single luminous intensity measurement.

Test yellow LED modules for luminous output at 77° F (25° C). Allow the modules to achieve thermal equilibrium for 60 minutes, while the modules are energized at nominal operating voltage, at a 8.3 percent (or 1/12) duty cycle or (5 sec On/55 sec Off).

Make a single point correlation measurement, accounting for measurement variables, at 77° F (25° C). Make a measurement for red and green at 165° F (74° C) with the lens at 120° F (49° C). Correlate the 165° F (74° C) measurement factored to the 77° F (25° C) measurement to the requirements of Table 1, 2 & 3 in Section 14.0. Reject LED modules not meeting this correlation.

III. Chromaticity. Measure a sample of two LED modules for chromaticity per the requirements of Section 14.2. Use a spectroradiometer for this measurement. Make this measurement at an ambient temperature of 77° F (25° C).

IV. Electrical.

i. Current. Measure a sample of six LED modules for current flow in amperes. Use the measured current values for quality comparison of Production Quality Assurance current measurements on production modules.

ii. Power Factor (PF). Measure a sample of six LED modules for power factor per the requirements of Section 15.6.1. Use a commercially available power factor meter to perform this measurement.

iii. Total Harmonic Distortion (THD). Measure a sample of six LED modules for total harmonic distortion per the requirements of Section 15.6.2. Use a commercially available total harmonic distortion meter to perform this measurement.

iv. Electronic Noise. Test a sample of one LED modules per the requirements of Section 15.6, with reference to Class A emission limits referenced in FCC Title 47, SubPart B, Section 15.

v. Controller Assembly Compatibility. Due to the low load current draw and high off-state impedance of LED modules, perform the following design qualification tests to ensure the module design is compatible and operates properly with load current switches and conflict monitors in NEMA and Type 170 traffic signal control units.

α.

Load Switch Compatibility. Test a sample of six LED modules for compatibility and proper operation with load current switches. Connect each LED module to a variable AC voltage supply. Monitor the AC line current into the LED module for sufficient current draw to ensure proper load switch operation while the voltage is varied from 80 volts RMS to 135 volts RMS. Reject LED modules whose current draw fails to ensure proper load current switch operation.

β.

Signal Conflict Monitor Compatibility. Test a sample of six LED modules for compatibility and proper operation with signal conflict monitors. Operated each LED module from a 135 volt AC voltage supply. Wire a 19.5 kΩ resistor in series in the hot line between the LED module monitor and the AC power supply. Wire a single-pole-single-throw switch in parallel across the 19.5 kΩ resistor. Wire a 220 kΩ shunt resistor between the hot line connection and the neutral line connection and the neutral line connection on the LED module. Test conflict monitor compatibility by measuring the voltage decay across the 220 kΩ shunt resistor as follows: Close

the single-pole-single-throw switch, shorting out the 19.5 kΩ resistor, allowing the AC power supply to illuminate the LED module. Next, open the switch and measure the voltage across the 220 kΩ shunt resistor for a decay to a value equal to or less than ten volts RMS within a time period equal to or less than 100 milliseconds. Repeat this test a sufficient number of times to ensure testing occurs at the peak of the AC line voltage cycle.

vi. Nondestruct Transient Immunity. Test a sample of six LED modules for transient immunity using the procedure described in Section 2.1.8, NEMA Standard TS 2-1992.

V. Environmental

i. Temperature Cycling. Perform temperature cycling on a sample of three LED modules per MIL-STD-883, Test method 1010. Make the temperature range in accordance with Section 2.3. Perform a minimum of 20 cycles with a 30-minute transfer time between temperature extremes and a 30-minute dwell time at each temperature. LED modules under test must be non-operating. Reject any LED module that fails to function properly or exhibits any evidence of cracking of the LED module lens or housing after temperature cycling.

ii. Moisture Resistance. Perform moisture resistance testing on a sample of three LED modules per NEMA Standard 250-1991 requirements for Type 4 enclosures.

iii. Mechanical Vibration. Perform mechanical vibration testing on a sample of three (3) LED modules per MIL-STD-883, Test Method 2007, using three four-minute cycles along each x, y, and z axis, at a force of 2.5 Gs, with a frequency sweep from two Hz to 120 Hz. Reject any module that exhibits loosening of the lens, of any internal components, or other physical damage.

See ODOT Supplemental Spec. 872, Light Emitting Diode, Traffic and Pedestrian Signal Lamp Units, dated April 21, 2006, for additional quality assurance for LED optical units.

O. Warranty for LED Optical Units.

1. Replace or repair LED modules if an LED module fails to function as intended due to workmanship or material defects within the first 60 months from the date of delivery.

2. Replace or repair LED modules which exhibit luminous intensities less than the minimum values specified in Table 1 Section 3.0 within the first 60 months of the date of delivery.

P. Mounting. Include all mounting hardware for signal heads with the item furnished, as indicated in Table 1327 for the signal mounting or as indicated on the plans. The hardware will conform to City requirements as details show.

In accordance with the plans, mount signal heads alone, forming a one-way head, or combine with additional heads to form two-way, three-way, or a maximum of four-way heads. Furnish multi-way heads with appropriate top and bottom brackets with an opening in the

center of the top bracket provided for mounting purposes. Using pipe spacers, correct signal face height inequalities for multi-way heads for proper accommodation between top and bottom brackets.

Observe the requirements that the bottom of all signals and signs on a span must be level with one another, with a minimum of 17 feet (5.2 m) clearance between the equipment and the roadway. This is usually measured at the crown of the roadway.

Table 1327
Sign and Signal Mounting Hardware

Mounting Type <i>S = Span Wire</i> <i>M = Mast Arm</i> <i>B = Bracket Arm</i> <i>P = Pedestal Top</i>	Sign and Signal Equipment			
	Traffic Signal Head	Pedestrian Signal Head	Internally Illuminated Signs	Lane Use Control Signal Head
Mounting Hardware	Mounting Type			
6 inch (150 mm) cast aluminum suspension clamp.	S		S	S
Adjustable clevis.	SM			SM
Combination galvanized cast iron balance adjuster and cast aluminum weatherhead	SM		SM	SM
Mast arm hanger or clamp	M		M	M
Pole clamps	B		B	
Clamshell Hardware		BP		
Post top reducer and coupling			P	
1-1/2 inch (40 mm) galvanized steel for mast arms, span wire assemblies and pedestal top mountings. 1-1/2 inch (40 mm) aluminum for bracket arms or polycarbonate for bracket arms of 15 inches (380 mm) or shorter.**	SMB		SMB	SM
1-1/2 inch (40 mm) lock nuts, washers and all other incidentals necessary to make the Assembly complete, dust and watertight.	SMB		SMBP	SM
Required clearance from bottom of Equipment to grade.	17 feet (5.2 m)	Minimum 8 feet (2.5 m)	17 feet (5.2 m)	17 feet (5.2 m)

** All pipe and fittings are aluminum schedule 40.

Q. Aiming of Signals. The light distribution of the traffic signal reflector and lens will give the greatest intensity straight in front and slightly down from the signal face.

Aim the signals as follows:

Vertical Aiming. For level approaches, mount all traffic signals so as to hang plumb. Where the approach has an angle, signal housing tilt 1/4 inch per 24 inches (10.4 mm per m) of elevation above grade for each one percent of approach grade.

Horizontal Aiming. Unless the traffic signal plan indicates otherwise, aim traffic signal heads horizontally, based on the following:

1. Two Signal Heads on Approach.
 - a. Aim left signal head horizontally with the beam of maximum intensity directed at a point five feet (1.5 m) to the right of the center line of the approach roadway, at a distance of 200 feet (61 m) from the stop line.
 - b. Aim right signal head horizontally with beam of maximum intensity directed at a point five feet (1.5 m) to the left of the right hand edge of the approach roadway, at a distance of 200 feet (61 m) from the stop line.
2. Two Through Traffic Signal Heads and One Left Turn Signal Head.
 - a. Aim left turn signal horizontally with beam of maximum intensity directed at the center of the left turn storage lane, if present, at a distance of 200 feet (61 m) from the stop line. If the storage lane is in excess of 200 feet (61 m) long, or otherwise on the center line at a distance of 200 feet (61 m) from the stop line.
 - b. Aim left signal head for through movement horizontally with the beam of maximum intensity directed at the center of the farthest left lane available for through traffic at a distance of 200 feet (61 m) from the stop line.
 - c. Aim right signal head as 1.b indicates above.
3. Aim horizontal point for auxiliary signal heads for special advance visibility conditions and/or signal heads facing curved approaches as the traffic signal plan indicates, or as the City Traffic Engineer directs.

1327.02 Optically Programmed Signal Heads. Furnish optically programmed signal heads in the arrangements the plans show. Incorporate in each signal section an optical system projecting an indication programmed to be visible only within boundaries of a specific area shown on the plans. Ensure that the optical system is capable of being veiled anywhere to within 15 degrees of the optical axis using procedures and opaquing material in accordance with the Manufacturer's instructions.

Signal sections conform to applicable portions of the ITE standard and the foregoing specifications for conventional optics traffic signal heads. Make optical sections of the 12 inch (300 mm) lens, and mounted alone or in combination with additional sections of optically programmed or conventional optics types to form signal faces and heads in the arrangements shown.

Make the components of the optical system:

- A.** Lamp
- B.** Lamp Collar
- C.** Optical Limiter-Diffuser
- D.** Objective Lens

Ensure that lamps have three prongs, a sealed beam having an integral reflector with stippled cover and an average rated life of at least 6,000 hours. Couple the lamp to the diffusing element with a collar including a specular inner surface. The diffusing element may be discrete or integral with the convex surface of the optical limiter. Ensure that the optical limiter provides an accessible imaging surface that focuses on the optical axis for objects 900 to 1,200 feet (275 m to 365 m) distance, and permits an effective veiling mask to be variously applied as the desired visibility zone determines. Provide the optical limiter with positive indexing means and make it of heat resistant glass. Make the objective lens a high resolution planar incremental lens hermetically sealed within a flat laminant of weather resistant acrylic or approved equal. Make the lens symmetrical in outline; the lid may be rotated to any 90 degree orientation about the optical axis without displacing the primary image. Ensure that the optical system accommodates projection of diverse, selected indicia to separate portions of the roadway such that only one indication will be simultaneously apparent to any viewer. Ensure that the projected indication conforms to ITE transmittance and chromaticity standards.

Construct the housing of optically programmed sections to include a plus or minus ten degree tilt adjustment from the horizontal while maintaining a fixed mounting axis. Rigidly mount optically programmed signal heads to prevent visibility boundary movement due to high winds or truck movement. Mount signals mounted on span wire and tie to a tether cable by a breakaway clamp installed in the lower section mounting opening.

Include an incandescent lamp in each optical section and of the type Table 1326.01 indicates.

Make the housing of die-cast aluminum parts conforming to ITE alloy and tensile requirements, and having a chromate preparatory treatment. Finish the exterior of the signal case, lamp housing and mounting flanges with a high quality baked enamel prime and finish paint. Make the final color black. Paint the lens holder and interior of the case optical black. Pre-drill the signal case and lens holder for backplates and visors. Construct the hinge and latch pins of stainless steel. Seal all access openings with weather-resistant rubber gaskets. Ensure that sheet metal parts, including visors and backplates, conform to ITE material requirements, and include a chromate preparatory treatment and optical black on all surfaces.

Include mounting hardware in the Item furnished and as Table 1327 indicates or the signal mounting plans indicate. Ensure that hardware conforms to the requirements in the details. Make the tether cable 1/8 inch (3 mm) braided stainless steel cable.

1327.03 Lane Use Control Signal Heads.

A. General. The unit consists of a single housing containing optical parts, lamps and accessories for displaying by artificial illumination either a "Red X" or a "Green (Down) Arrow" indication as plans specify. Make the indications on an opaque background.

Ensure that testing conforms to the applicable provisions of Item 1313 - Testing.

B. Dimensions (Face Size).

Size	Type	Dimension				Strokes Of Indication	
		Width		Height			
		Minimum	Maximum	Minimum	Maximum	Minimum	Maximum
12 inches (300 mm)	Single Indication	12 inches (300 mm)	14 inches (350 mm)	12 inches (300 mm)	14 inches (350 mm)	1-1/2 inch (40 mm)	3 inches (75 mm)

C. Colors and Dimensions. Ensure that colors and indication dimensions comply with the latest ITE Standard for "Adjustable Face Vehicle Traffic Control Signal Heads". The "RED X" cross bars have a minimum length of 15 inches (380 mm).

D. Optical Performance. Ensure that the color of lane use control signal indications is clearly visible for 1,320 feet (400 m) at all times under normal atmospheric conditions, unless otherwise physically obstructed. Ensure that the visibility angle of the lane use control signal is at least as great as plans specify for the standard circular traffic signal head. Design the signal to minimize the effect of sun phantom (i.e., reflection of incident [outside] light rays) to provide the maximum blankout effect of any indication not illuminated.

E. Single Indication Type. Ensure that lane use control signals of the single indication type meet the latest ITE Standards for "Adjustable Face Pedestrian Signal Heads" with the following supplements. Plans specify the indication.

1. Make the reflectors highly polished specular finished aluminum.
2. Make lens of prismatic glass diffusing type with fired on legends with opaque masking on back of lens to maximize blankout effect.
3. Make lamps the clear type and installed with the open portion of the filament in the upward position.

4. The lamps and rating for the signal head is:

Signal Size	Minimum Life (Hours)	Rated Watts	Light Volts	Center	Industrial Lamp Number
12 inch (300 mm) Signal	8,000	121	125	3 inches (75 mm)	121 A/TS
18 inch (450 mm) Signal	1,000	200	130	6 inches (150 mm)	200 PS 30/34

F. Housing. Make the housing of sheet aluminum, a corrosion-resistant aluminum, or aluminum-alloy die casting of sufficient strength of virgin ultraviolet stabilized polycarbonate resin. Weld all metallic joints continuously to prevent the entrance of moisture.

Make all screws, nuts, bolts and fastening devices used in the signal housing stainless steel. Mount all components in the housing(s) so they are easily accessible without de-energizing or disassembling the signal.

G. Visor. Make the visor 18 gage (0.05") (12 mm) minimum aluminum or polycarbonate, securely attached to the housing, as paragraph G indicates. Ensure that the visor attached to the door does not interfere with the opening of the door.

Construct the visor so that the indication is shielded from direct sunlight when the sun is 45 degrees or more above the horizon.

H. Wiring. Wire the signal heads assembly with a minimum of 300° F (150° C), 600 volt, No. 18 AWG stranded copper fixture wire per articles 310-2 (a), 402 and 410 of the N.E.C.

Provide terminal strip rated at 600 volts with each pole rated at 15 amps for wiring connection to external control cable.

I. Painting. Paint aluminum equipment in accordance with Item 1317 and the following:

1. First coat (all surfaces) - Epon Oxide Baking Primer, Federal Spec. TT-P-636.
2. Second coat (all Surfaces) - Medium Gray Alkyd Urea Exterior Baking Enamel, Federal Spec. TT - E-480B.
3. Third coat (yellow surface) - Federal Yellow Alkyd Urea Exterior Baking Enamel, Federal Spec. TT-E-489F, Color 13538.
4. Third coat (green surface) - Dark Green Alkyd Urea Exterior Baking Enamel, Federal Spec. TT-E-489, Color 14062.
5. Third coat (flat black surface) - Alkyd Urea Black Synthetic. Heat-resisting Glyceryl Phyhalate Type 4, instrument black military Spec.E-5557.

J. Installation. Include mounting hardware in the Item furnished as indicated in Table 1327 for the signal mounting plans indicate. Ensure that the installation and all hardware conform to detail requirements.

Position signals over the center of the lane(s) plans specify except where plans indicate offset positioning.

Include the cost of furnishing and installing lamps in the bid price for the respective signal head.

1327.04 Pedestrian Signal Heads. Furnish pedestrian signal heads conforming to the ITE Specification "Adjustable Face Pedestrian Signal Head Standard," except as may be otherwise indicated below. The signal heads display alternately the legends "Hand" symbol in Portland Orange light and "Walking Man" in Lunar White light (with or without countdown display).

A. Housing. Type D2 Pedestrian Signal – Make the housing single piece cast aluminum with 1-1/2 inch (40 mm) reinforced mounting hubs on the top and bottom with serrated bossed openings. Make the door frame of one piece cast aluminum. Door fastens with a captive stainless steel wingnut, and latching or unlatching of the door requires no tools. Access to the lamps is direct by opening the door. Use stainless steel for all screws, nuts, bolts, and fastening devices used in each type signal housing.

Make all gaskets in each type housing which are exposed to the atmosphere dust and moisture tight. Make the gaskets of neoprene or an approved equivalent. The City will not accept cork gaskets.

B. Dimensions. Table 1327.03 indicates signal head face dimensions.

Table 1327.03

Signal Type	Face				Legend	
	Width		Height		Symbol Height	
	Minimum	Maximum	Minimum	Maximum	Nominal	Tolerance
16" LED Type D2	13 inches (330)	16 inches (400 mm)	15-1/2 inches (395 mm)	18 inches (460 mm)	4-1/2 inches + 1/8 inch (115 mm ± 3 mm)	5/8 inch -1/32 inch +3/32 inch (16 ± 1 mm)

C. Arrangement of Symbols and Colors. The color for the "Walking Man" symbol is Lunar White and the color for the "Hand" symbol is Portland Orange. The colors are to comply with the color standards of the ITE Specification.

1. Type D2 Single Section LED Type Signal. The "Hand" symbol is in the left half and the "Walking Man" symbol on the right half of the lens. Make the face of 0.250 inch (6.5 mm) polycarbonate plastic and textured on outside surface. The "Hand" message is Portland orange when illuminated and the "Walking Man" message is Lunar white when illuminated.

Make the symbols cutout type with black background; these produce bright and uniform messages even in strong ambient lighting condition. When an optical section is not energized, that section blanks out so that the message is not readable even under very strong ambient lighting conditions.

2.

Type D2 Single Section LED Countdown Type Signal. Integrate the "Hand" and "Man" symbol on the left side of the display. The right side consists of the countdown display. The countdown display must have a "ON/OFF" switch to disable the countdown portion of the display.

D. Visor.

Make the visor of the "Eggcrate" design in one-piece injection molded polycarbonate plastic. Make the visor 1-1/2 inch (40 mm) deep with horizontal members spaced 1/2 inch (12 mm) apart. Place enough vertical members to assure holding the horizontal members parallel. Install the visor parallel to the face and mount to the door frame with stainless steel screws.

E. Painting. Paint the aluminum signal head in accordance with Item 1317 and the following:

Clean the unit properly and give the exterior of the housing and the entire visor one coat of chromate primer and two coats of automotive baking enamel. Bake each coat individually to a hard finish before applying the next coat.

F. Optical. The purpose of this specification is to provide the minimum performance requirements for the LED "Walking Man" and "Hand" icon pedestrian signal modules (hereafter called module or modules). This specification requires the following size (nominal message bearing surface): 16 inch by 18 inch (406 mm x 457 mm). This specification is not intended to impose restrictions upon specific designs and materials that conform to the purpose and the intent of this specification. This specification refers to definitions and practices described in "Pedestrian Traffic Control Signal Indications" published in the Equipment and Materials Standards of the Institute of Transportation Engineers, referred to in this document as "PTCSI" and in the Manual on Uniform Traffic Control Devices (MUTCD). This specification applies to modules purchased after the effective date of these specifications.

G. Physical and Mechanical Requirements LED Modules. Provide modules designed as retrofit replacements for existing pedestrian signal indication lamps that do not require special tools for installation. Provide retrofit replacement modules that fit into existing pedestrian signal housings built for the PTCSI sizes listed in Section 1 of the "Walking Man" and "Hand" icon pedestrian signal indication Standard without modification to the housing. See PTCSI 4.2.1 for housing sizes.

Provide retrofit replacement modules that only require the removal of the existing optical unit components, i.e., lens, lamp module, gaskets, and reflector, for installation into existing pedestrian signal housing. Additionally, provide retrofit replacement models that are weather tight, fit securely in the housing, and connect directly to existing electrical wiring.

1. The Module.

- a. Provide retrofit modules capable of replacing the optical unit.
- b. The module lens may be a replaceable part without the need to replace the complete module.
- c. Provide modules that include full "Walking Man" and "Hand" icons (not outlines). The configurations of the "Walking Man" and "Hand" icons are illustrated in Figure 1 and Figure 2, respectively.



Figure 1

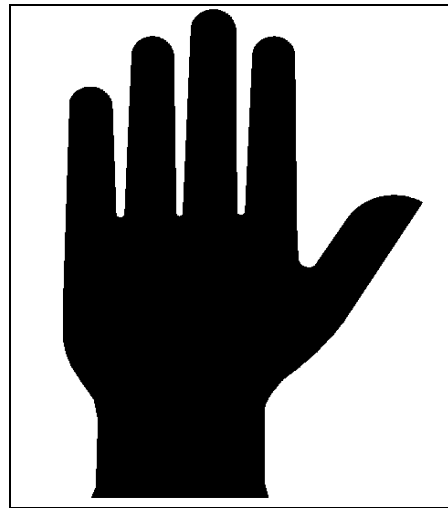

Figure 2

2. Dimensions for Figure 1 and Figure 2. For the nominal message bearing surface (module) size, use the corresponding height and width:

Height = 11 inches (280 mm)
Width = 7 inches (180 mm)

H. Environmental Requirements.

1. Provide modules rated for use in the ambient operating temperature range (measured at the exposed rear of the module) of -40° F to +165° F (-40° C to +°75 C).
2. Design the pedestrian module to meet NEMA 250 Hose down Test. Conduct the test on a stand-alone unit. Do not use protective housing.
3. Provide modules with UV stabilized lens.

I. Construction.

1. Provide modules that are single, self-contained devices, not requiring on-site assembly for installation into an existing traffic signal housings. Design the power supply to fit and mount inside the pedestrian signal module.
2. Design the assembly and manufacturing process for the module to assure all internal LED and electronic components are adequately supported to withstand mechanical shock and vibration from high winds and other sources.

J. Materials.

1. Use materials for the lens and LED module construction that conform to ASTM specifications where applicable.
2. Construct enclosures containing the power supply and electronic components of the LED module of UL94VO flame retardant materials. The lens of the LED module is excluded from this requirement.

K. Module Identification.

1. Identify each module on the backside with the Manufacturer's name, model number(s) and serial number(s).
2. Identify the following operating characteristics: nominal voltage, power consumption, and Volt-Ampere.

L. Photometric Requirements.

1. Luminance, Uniformity & Distribution.
 - a. Provide modules capable of maintaining the minimum luminance values listed in Reference 1 and Reference 2 under the operating conditions defined in Sections 2.3.1 and 4.2.1 for a minimum period of 60 months. Make measurements perpendicular to the surface of the module at nine separate points on the icon. These values may decrease up to 50 percent from these table values beyond 15 degrees from the perpendicular in either to the left or right on a horizontal plane.

Reference 1 - Maintained Minimum Luminance Value
"Walking Man" icon of the Module
5,300 candelas/square meter

Reference 2 - Maintained Minimum Luminance Value
"Hand" icon of the Module
3,750 candelas/square meter

- b. Provide modules with the uniformity of the "Walking Man" and "Hand" icons' illumination meeting a ratio of not more than one to five between the minimum and maximum luminance measurements (in Cd/m²).

2. Chromaticity. For the standard colors for the LED Pedestrian Signal Module, use Lunar White for the "Walking Man" and Portland Orange for the "Hand" icon. The colors for these icons must conform to the CIE chromaticity diagram x, y coordinates as follows:

The white area is defined by the sum of these two areas that are contiguous, and are defined by the following lines:

	First Area	Second Area
Yellow Boundary	$x = 0.400$	$x = 0.450$
Blue Boundary	$x = 0.280$	$x = 0.400$
Green Boundary	$y = 0.7917x + 0.0883$	$y = 0.7917x + 0.0483$
Purple Boundary	$y = 0.4600x + 0.1810$	$y = 0.4600x + 0.2210$

The Portland Orange area is defined as:

	First Area
Red Boundary	$y = 0.331$
Yellow Boundary	$y = 0.390$
White Boundary	$y = 0.997 - x$

M. Electrical.

1. General. Furnish wiring and terminal blocks that meet the requirements of Section 13.02 of the VTCSH Standard. Provide two secured, color coded, 36-inch (914 mm) long 600 volt, 16 AWG minimum, jacketed wires, conforming to the National Electrical Code, rated for service at +220° F (+105°C), for electrical connection.

2. Voltage Range.

a. Provide LED modules that operate from a 60 ± 3 Hertz AC line power over a voltage range from 80 volts AC RMS to 135 volts AC RMS. Provide modules that have sufficient current draw to ensure compatibility and proper triggering and operation of load current switches and conflict monitors.

b. Nominal operating voltage for all measurements must be 120 ± 3 volts RMS.

c. Provide LED modules whose luminous intensity is not affected by more than + ten percent by fluctuations in line voltage over the range of 80 volts AC to 135 volts AC.

d. Provide LED modules with circuitry that prevents flickering at less than 100 Hz over the voltage range specified in Section 4.2.1.

e. Low Voltage Turn Off. Provide modules that do not illuminate when the applied voltage is less than 35 volts AC RMS. Test each icon for this condition by first fully illuminating it at the nominal operating voltage and then reducing the applied voltage to the point where there is no illumination. This point must be greater than 35 volts RMS AC.

f. Turn-On and Turn-Off Time. Provide modules where each icon of the module reaches 90 percent of its full illumination (turn-on) within 100 msec. of the application of the nominal operating voltage. Provide modules that do not illuminate (turn-off) after 100 msec. of the removal of the nominal operating voltage.

g. Provide pedestrian signal units that default to the "Hand" symbol during abnormal conditions when nominal voltage is applied to the unit across the two-phase wires (rather than being applied to the phase wire and the neutral wire).

3. Transient Voltage Protection. Provide modules whose on-board circuitry includes voltage surge protection to withstand high-repetition noise transients and low-repetition high-energy transients as stated in Section 2.1.6, NEMA Standard TS-2, 1998, or the latest version.

4. Electronic Noise. The modules and associated on-board circuitry must meet Federal Communications Commission (FCC) Title 47, Sub Part B, Section 15 regulations concerning the emission of electronic noise.

5. Power Factor (PF) and AC Harmonics.

a. Furnish modules that provide a power factor of 0.90 or greater when operated at nominal operating voltage, and 77° F (25° C).

b. Provide modules that when operated at nominal operating voltage induce total harmonic distortion into an AC power line of 20 percent or less.

N. Quality Assurance.

1. General. Unless otherwise specified, conduct all of the required tests at an ambient temperature of 77° F (25° C) and at the nominal operating voltage of 120 volts AC RMS.

a. Manufacture modules in accordance with a Vendor quality assurance (QA) program. Furnish only products from Vendors whose QA programs include two types of quality assurance: (1) design quality assurance, and (2) production quality assurance. Include statistically controlled routine tests as part of the production quality assurance to ensure minimum performance levels of LED modules built to meet this specification.

b. Keep QA process and test result documentation on file for a minimum period of seven (7) years.

2. Conformance. Do not label, advertise or sell as conforming to this specification any module design(s) not satisfying design qualification testing and production quality assurance testing performance requirements.

3. Design Qualification Assurance.

a. Perform Design Qualification testing on new module designs, and when a major design change has been implemented on an existing design.

Unless otherwise specified, conduct all of the tests on the same set of randomly selected modules, hereafter called the sample set, at an ambient temperature of 77° F (25° C) and at the nominal operating voltage of 120 volts AC RMS.

b. Perform testing once every five years or when the module design or LED technology has been changed. Retain test data (by the module Manufacturer) for a minimum period of seven years and for a period of at least five years beyond the last date of manufacture of that model type.

4. Production Quality Assurance.

a. Subject all new modules to Production Quality Assurance testing prior to shipment. Reject any module that fails to meet requirements of the QA tests. Maintain QA test results for a period of four years.

5. Warranty. Provide the following warranty provisions from Manufacturer: LED signal modules(s) that fails to function as intended due to workmanship or material defects within the first 60 months from date of deliver will be replaced or repaired at no cost to the City of Cincinnati.

O. Optical Performance. Ensure that it is possible to discern which message is illuminated and that the message is readable to normal eyesight from a distance of 100 feet (30 m) on a bright, clear day, in direct sunlight, with the visor(s) removed.

P. Wiring. Provide each lamp receptacle with two coded No. 18 or larger insulated copper lead wires connecting the lamps to the terminal strip. Ensure that wiring has approved 600 volt insulation, capable of withstanding 221° F (105° C) and is long enough to provide easy accessibility without disconnection wires when opening the unit for service.

Q. Terminal Block. Locate a terminal block having a minimum of seven terminals so as to be easily accessible when opening the unit. Terminate wires for interior connections to the external wiring on this terminal block. Provide entry for external wiring through both the top and bottom mounting hubs to the terminal block.

R. Installation. Include mounting hardware in the item furnished, as indicated in Table 1327 for the signal mounting plans indicate.

Provide mounting hardware of "Clamshell" design, constructed of cast aluminum alloy, black finish. Dimensions not to exceed: 11-1/4 inches (286 mm) high by 5-1/2 inches (140 mm) wide by 2-3/4 inches (70 mm) deep. Design hardware to allow thru-bolt, lag screw or steel band mounting.

Secure the closed signal half of the assembly to the pole half of mounting hardware by use of a flathead socket bolt and tighten using a 3/16 inches (5 mm) Allen wrench.

Terminate field wiring on a horizontally mounted three-position terminal block located on the upper half of the signal mounted section of the mounting hardware.

Provide mounting hardware with a neoprene gasket to provide a weather tight seal.

Provide warranty for clamshell mounting bracket and hardware for two years from the date of shipment covering all materials and workmanship.

Ensure that the installation and all hardware conform to the detail requirements.

S. Manufacturer.

1. The D2 type Pedestrian signals are the Indicator Controls Corporation model 7037 without the clamshell mounting hardware or approved equal.

2. Pedestrian signals are the McCain model 1000 with the McCain clamshell mounting hardware or an approved equal.

1327.05 School Flasher, Installation Only. The work of this item consists of installing the school flasher assembly (the sign face, flashing amber beacons and illuminated speed numeral). City will furnish all equipment except mounting hardware.

Furnish and install the bracket arms of the length plans specify, and all pole mounting hardware and all accessories required to install the complete school flasher assembly.

Make all bracket arms 1-1/2 inch (40mm) schedule 40 galvanized steel pipe. Use galvanized pole plates with through bolts and leg screws on wood pole installations. Use galvanized pole clamps on steel pole installations.

Make the installation in accordance with the plans and details.

Furnish the school flasher time control where plans require under Item 1324.07.

1327.06 Covering of Traffic Signals. Not in Service - New: Keep all Signal heads installed but not in operation completely covered at all times with burlap, heavy corrugated cardboard, or other approved material, so that the signal lenses are not visible from any point. Remove or de-energize lamps in signal heads covered with cardboard, burlap, etc., until the covering is removed and the signals are put into operation. If the covers come off for any reason, the Contractor must recover them within 24 hours of notification. If the Contractor does not recover them, the City will do the work and charge the Contractor.

To Be Removed or Temporarily Disconnected: Cover the existing signal heads when removed or temporarily disconnected from operation with burlap, heavy corrugated cardboard, or other approved material and remove or de-energize lamps until the Contractor removes or restores the signal heads. Do not remove existing signal heads until the new equipment is in

operation. If the covers come off for any reason, the Contractor must recover them within 24 hours of notification. If not, the City will do the work and charge the Contractor.

City will make payment for covering of traffic signals incidental to the various items of the bid, which require new, removed or temporary signal equipment.

Provide coverings for vehicular, lane use and pedestrian signal heads as the City directs.

1327.07 Five Section Traffic Signal Assembly. Ensure that all traffic signal heads comply with the requirements of section 1327.01, Vehicular Traffic Signal Head. Construct the assembly as shown in the TRAFFIC AND ROAD OPERATION STANDARD DRAWING ES-3-5. The Traffic Services Bureau supervisor, phone number 513-352-3712, must approve the completed signal assembly before installation.

1327.08 Method of Measurement. Signal heads are measured as complete units in place and accepted, including all support and mounting hardware, optical programming as plans specify, aiming, lamps, tether cable as specified and covering.

1327.09 Basis of Payment. City will make payment at the Contract unit price bid for each signal head as plans specify; payment includes all labor, material, tools, equipment, and incidentals necessary to furnish and install the item complete, tested and accepted.

Item	Unit	Description
1327	Each	Vehicular Signal head, assembly ____ Section, ____ inch lens, ____ way.
1327	Each	Optically programmed Signal head assembly ____ Section, 12 inch lens, ____ way.
1327	Each	Lane Use Control Signal head assembly ____ Controlled ____ face.
1327	Each	Lane use control signal head assembly, ____ inch ____ lens, ____ way.
1327	Each	Pedestrian Signal head assembly, ____ type ____.

ITEM 1328 Traffic Signal Detectors

1328.01 Detector Amplifier, Installation Only. The work of this item consists of hauling and installing detector amplifiers as plans specify, as the City of Cincinnati furnishes, in accordance with the plans and details. Install the amplifiers in the traffic signal controller cabinet, or separate cabinet if plans specify, and make all wiring connections in accordance with the details.

1328.02 Detector Pavement Cutting. Saw slots in the pavement for installation of wire for vehicle detector loops in accordance with the configuration dimensions, and combinations plans show. Chamfer all corners with a full depth cut to eliminate sharp corners. Overlap the intersection of saw cuts so that the slots have full depth and a smooth bottom. Install the detector loop in clear, dry weather and ensure that the sawed slot is completely clean of dust and debris and thoroughly dry. Cut an extension from the loop to the pavement edge to permit wire routing to an adjacent pullbox or conduit fitting. When going through curbs, use Item 1321.04 PVC conduit to take the wire from the pavement edge through the curb and on into the pullbox or conduit fitting. Where no curb is present, end the sawcut six inches (150 mm) before the pavement edge. From that point, route the wire through Item 1321.04 PVC conduit to an adjacent pullbox or conduit fitting.

Make the slot width 3/8 inch (10 mm) and slot depth four inches (100 mm) in asphalt, and two inches (50 mm) in concrete, with the minimum depth providing a covering above the uppermost wire in the slot of no less than one inch (25 mm) in concrete and three inches (75 mm) in asphalt. If floating of the wire occurs, bend one inch (25 mm) of 1/4 inch (6 mm) O.D. vinyl tubing and wedge it into the slot at two-foot (600 mm) centers to keep the wire down.

Following pavement cutting and cleaning, install the detector wire according to Item 1323.01.

Where the saw cut crosses any construction joint or cracks in concrete or asphalt pavement, drill a 1-1/2 inch (40 mm) diameter hole at the joint and provide a relief loop for the detector wire. Use installation methods and materials as details indicate.

Seal slots with a flexible embedding sealant approved by the City Traffic Engineer and as details indicate. Make the sealant an epoxy type and must be on the ODOT QPL. Before applying sealant, brush or blow clean all slots of loose material, and dry completely. Mix and place the sealant according to the Manufacturer's instructions. Fill the slots completely and leave them undisturbed until cured. Remove any excess or spillage.

Saw detector wire installations in new asphalt and embed with sealant in an undersurface course with subsequent covering by the surface course, subject to the Engineer's approval. Do not make detector wire installations in existing brick or unstable bituminous roadways.

Test the loop detector wire in accordance with Item 1313 before and after applying loop sealant.

The City will include payment for the sealant in the Item of Saw Cutting.

1328.03 Loop Detector Installed In Duct. The Work of this item consists of installing conduit in areas trenched for this purpose or under new concrete roadway, whichever plans specify.

Where the plans require installation of duct in trenched areas, the work includes Item 1321.02 trenching in paved areas to the depth and width specified, and installing Item 1321.04 PVC conduit Type I concrete encased, formed in the dimensions plans specify. For loop detector wire, use multi-conductor traffic signal cable, as plans and details specify, installed in the conduit and spliced to form multi-turn loops in the specified pullbox or conduit fitting. Item 1323 Loop detector wire is a separate pay item. This work also includes restoration of the paved area in accordance with Item 1334.

Where the plans require installation of duct under new concrete roadway, include Item 1321.04 - two inch (50 mm) PVC conduit Type II - formed in the dimensions plans specify, and include the applicable Item 202 for removing and disposing of existing pavement and Item 452 for installing new concrete pavement without reinforcing where these items are not included under roadway items. Additional items may be required contingent on the conditions and must be specified.

The City may make payment for each item required or on a lump sum basis as specified.

1328.04 Overhead Microwave Detector, Installation Only. The work of this item includes installing overhead detectors with cable, which the City furnishes in accordance with the plans, and details. The Contractor may make field adjustment of equipment as the Engineer directs. The cost associated with this adjustment is incidental to the overall cost of Contract.

1328.05 Overheight Infrared Detector. The work of this item includes installing overhead detectors with cable, which the City furnishes in accordance with the plans and details. The Contractor may make field adjustment of equipment as the Engineer directs. The cost associated with this adjustment is incidental to the overall cost of the Contract.

1328.06 Video Detection. The work of this item includes installing overhead detectors with cable in accordance with the plans and details. The Contractor may make field adjustment of equipment as the Engineer directs. The cost associated with this adjustment is incidental to the overall cost of Contract.

A. General.

1. This specification sets forth the minimum requirements for a system that detects vehicles on a roadway using only video images of vehicle traffic utilizing video transmission between the camera sensor and video detection processor.
2. Provide video detection system consisting of video cameras, a video detection processor and odd numbered phase extension modules which mount in a standard input file of a 170 controller, a pointing device, cabling, and camera attachment mounting hardware.
3. Include software that detects vehicles in multiple lanes using only the video image. Define detection zones using only an on board video menu and a pointing device to place the zones on a video image. Provide system with up to 24 detection zones per camera available. Provide system that does not require a separate computer to program the detection zones.

B. Functional Capabilities.

1. Furnish processor that detects the presence of vehicles in up to 24 detection zones per camera. A detection zone is approximately the width and length of one car.
2. Furnish system that permits the programming of detection zones via an on board menu displayed on a video monitor and a pointing device connected to the processor. The menu must facilitate placement of detection zones and setting of zone parameters or to view system parameters. Provide system that does not require a separate computer for programming detection zones or viewing system operation.
3. Provide system with processor capable of storing up to three different detection zone patterns and switching to any of the three different detection patterns within one second of user request via menu selection with the pointing device.
4. Provide system with processor that detects vehicles in real time as they travel across each detector zone.
5. Provide system with processor that has an RS232 port for communications with an external computer. Provide processor RS232 port that is multi-drop compatible.
6. Provide system with processor capable of accepting new detector patterns from an external computer through the RS232 port when the external computer uses the correct communications protocol for uploading detector patterns. Provide Windows-based software designed for local or remote connection and providing video capture, real-time detection indication and detection zone modification capability with the system.
7. Provide system with processor capable of sending its detection patterns to an external computer through the RS232 port when requested when the external computer uses the correct communications protocol for downloading detector patterns.

C. Vehicle Detection.

1. Provide system that supports a minimum of 24 detection zones that can be sized to suit the site and the desired vehicle detection region.
2. Provide system where a single detection zone is capable of replacing multiple loops and detection zones may be AND'ed or OR'ed together to indicate vehicle presence on a single phase of traffic movement.
3. Provide system where placement of detection zones is done using only a pointing device and a graphical interface unit built into the processor and is displayed on a video monitor. Provide system that permits drawing detection zones on the video image from the video cameras and does not require a separate computer to program detection zones.
4. Provide system with processor capable of saving a minimum of three detection zone patterns within the processor memory. Provide processor with non-volatile memory that prevents data loss during power outages. Provide processor that continues to operate (e.g.

detect vehicles) using the existing zone configuration even when the operator is defining/modifying a zone pattern. Provide system that does not put the new zone configuration into effect until the configuration is saved by the operator.

5. Furnish system that permits the selection of the detection zone pattern for current use through a menu or remote computer via RS232 port. Provide system that allows the activation of a detection zone pattern for a camera from processor memory and displays that detection zone pattern within one second of activation.

a. Provide system where the corners of the detection zone flash on the video overlay display screen to confirm the detection of a vehicle when the vehicle crosses a detection zone.

b. Provide system that is at least 98 percent accurate detecting vehicles in good weather conditions and at least 96 percent accurate under adverse weather conditions (rain, snow, or fog). Detection accuracy is dependent upon site geometry, camera placement, camera quality and detection zone location, and these accuracy levels do not include allowances for occlusion or poor video due to camera location or quality.

c. Place detector so that the distance between the detector and the camera is not more than ten times the mounting height of the camera.

d. Provide system with processor capable of providing up to 24 channels of vehicle presence detection per camera through a standard input file edge connector and one or more extension modules.

e. Furnish system with processor capable of providing dynamic zone configuration to enable normal detector operation of existing channels except the one where a zone is being added or modified during the setup process. Furnish processor that outputs a constant call on any detection channel corresponding to a zone being modified.

f. Provide system such that detection zone setup does not require site specific information such as latitude, longitude, date and time to be entered into the system.

g. Provide system such that the processor outputs a constant call for each enabled detector output channel during the background learning period and if a loss of video signal occurs.

h. Provide system such that detection zone outputs are configurable to allow the selection of presence, pulse, extend, and delay outputs. Timing parameters of pulse extend and delay outputs must be user definable between 0.1 and 25.0 seconds.

i. Furnish system such that up to six detection zones are capable of counting the number of vehicles detected. Furnish system that is capable of storing the count value internally for later retrieval through the RS232 port. Provide system that allows for the data collection interval to be user definable in periods of five, 15, 30 or 60 minutes.

D. Processor and Extension Module.

1. Design the processor and extension module to mount in a standard 170-type rack using the edge connector to obtain power and provide contact closure outputs. Furnish processor or extension modules that can be mounted in a standard input file without the use of adapters and without rewiring.
2. Provide processors and extension modules capable of operating in a temperature range from -30° F to $+165^{\circ}$ F (-34° C to $+74^{\circ}$ C), and a humidity range from 0 percent RH to 95 percent RH, non-condensing.
3. Furnish processors and extension modules powered by 12 or 24 volts DC that automatically compensate for the different input voltages.
4. Furnish processors whose power consumption does not exceed 300 milliamps at 24 volts DC. Furnish extension modules whose power consumption does not exceed 120 milliamps at 24 volts DC.
5. Furnish processors that include a multi-drop compatible RS232 port for serial communications with a remote computer. Use a nine-pin, "D" subminiature connector on the front of the processor.
6. Furnish processors that utilize flash memory technology to enable the loading of modified or enhanced software through the RS232 port without modifying the processor hardware.
7. Furnish processors and extension modules that include detector output pin put out compatibility with industry standard detector racks.
8. Furnish processors whose fronts include detection indications (such as LED's) for each channel of detection that display detector outputs in real time when the system is operational.
9. Furnish processors whose fronts include one or two BNC input connections suitable for RS170 video inputs as required. Provide video input that includes a switch selectable 75 ohm or high impedance termination to allow camera video to be routed to other devices, as well as input to the processor for vehicle detection. Video must be inputted via a BNC connector on the front face of the processor. RCA type connectors/jacks for video input are not allowed. Do not route video via the edge connectors of the processor.
10. Furnish processors whose fronts include one BNC video output providing real time video output that can be routed to other devices. An RCA-type connector/jack for video output is not allowed.
11. Furnish processors and extension modules whose front panel(s) have a detector test switch to allow the user to place calls on each channel. Provide test switch that is capable of placing either a constant call or a momentary call depending on the position of the switch.

E. Camera.

1. Furnish camera that is capable of producing a useable video image of the bodies of vehicles under all roadway lighting conditions, regardless of time of day. The minimum range of scene luminance over which the camera produces a useable video image is the minimum range from night time to day time, but not less than the range of 0.1 lux to 10,000 lux.

2. Furnish camera that outputs monochrome video with resolution of not less than 350 lines vertical and 500 lines horizontal.

3. Furnish camera that includes auto-iris control based upon average scene luminance and is equipped with an auto iris lens.

4. Furnish camera that includes a variable focal length lens with variable focus that can be adjusted to suit site geometry without opening the camera housing. Adjust the lens iris to minimize image variations.

5. House the camera in an environmentally sealed enclosure. Equip the camera enclosure with a sun shield that prevents sunlight from directly entering the lens. Furnish sunshield that is less than six inches (150 mm) in diameter, less than 26 inches (660 mm) long and weighs less than 12 pounds (5.5 kg) with the camera and lens mounted inside the enclosure. Include a thermostatically controlled heater in the camera enclosure to assure proper operation of the lens iris at low temperatures and prevent moisture condensation on the optical faceplate of the enclosure. Furnish camera that operates satisfactorily in a temperature range from -30° F to $+130^{\circ}$ F (-34° C to $+55^{\circ}$ C) and a humidity range from 0 percent RH to 100 percent RH when mounted outdoors in the enclosure.

F. Installation.

1. Furnish power cable that is 16 AWG, three-conductor cable based on a per foot price. Provide power cabling rated for 600 volts and RHH/RHW/USE insulated.

2. Provide coax cable that is high frequency, low-loss 75 ohm type with cable loss of no more than .78 dB/100 feet (30.5 m) at 10 MHz. Furnish cable suitable for installation in conduit or overhead with appropriate span wire. Use BNC plug connectors at both the camera and cabinet ends.

3. Furnish each camera unit with mounting brackets suitable for wood, steel pole, and other mast arm type applications. Include the brackets as incidental to the cost of the camera.

G. Warranty. Provide a limited two-year warranty from the Supplier for the video detection system.

H. Maintenance and Support. Include with the cost of the system a Supplier-lead training program consisting of two eight-hour training sessions that include field set up and installation instruction from a Factory Authorized representative. Provide Supplier-furnished trouble shooting and additional operational support by telephone and up to three field visits annually, throughout the duration of this Contract.

1328.07 Pedestrian Pushbutton With Associated Signs. Make pushbuttons of sturdy two-piece construction, consisting of an aluminum base housing and a vandal-resistant removable button/cover assembly with all other parts attached.

Provide button cover with bright red LED that flashes to acknowledge pushbutton activation. Construct button of 316 stainless steel and design to have a maximum operating force of three pounds (1.4 kg). Furnish base housing with captive stainless steel nuts to secure button cover assembly by using 1/4-20 stainless steel mounting bolts. Design and construct pushbutton to be approximately 3.4 inches (86 mm) in diameter and 2.5 inches (64 mm) deep when assembled. Design and construct pushbutton to operate in temperatures ranging from -30° F to 165° F (-34° C to 74° C) at a voltage range of 15 to 36 volts AC or 12 to 28 volts DC.

Ensure that the housing has a curved back surface for mounting on poles of various diameters. The curved surface may be integral with the housing or may be on an adaptor supplied with a flat back type housing. Attach the cover assembly to the housing with stainless steel machine screws, resulting in a weatherproof and shockproof design. Provide a hole threaded for a 1/2-inch (12 mm) pipe in the housing upper and/or lower sides to attach the conduit.

Orient push buttons as plans show. Service pushbuttons mounted on steel poles by wiring inside the poles, as plans detail. Provide holes 3/4 inches (20 mm) in diameter throughout the back of the housing and the pole wall, install an insulated bushing, and route wiring through so that no external wiring is visible. Plug the unused conduit attachment hole(s). Make housing mounting as details show. Service pushbuttons mounted on wooden poles through conduit and mount them as plans show.

Furnish pushbuttons with two instruction signs, one mounted below the pushbutton and one mounted across the street on top of the complemented actuated pedestrian signal. Make mounting details and locations as details and plans show.

Make the sign below the pushbutton an R-73A-MOD-5, nominally five inches by eight inches (125 mm x 200 mm) containing the legend: "TO CROSS STREET PUSH BUTTON WAIT FOR WALK LIGHT" arranged as plans show.

Make the sign above the pedestrian signal an R-73B-MOD-18, nominally 18 inches x 24 inches (450 mm x 600 mm) containing the legend: "PUSH BUTTON FOR WALK LIGHT" arranged as plans show.

Ensure that signs meet the requirements of Item 1329.03.

1328.08 Method of Measurement. Measure detector amplifiers as complete units in place, connected, tested and accepted.

Measure detector pavement cutting as the total number of feet (meters) of slots from the edge of the pavement to the magnetometer probe locations or to the loop and around the loop perimeter using the overall dimensions and making no adjustments for the diagonal corners. The work includes the application of sealant, and cleaning and blowing out the slotted areas.

Measure loop detector installed in duct as more than one specified pay item (i.e. conduit, trenching paved areas, concrete, or conduit, excavation and new pavement). The measurement would then be comprised of each of the items specified

OR

Measure loop detector installed in duct as a complete item per square foot (m²) of area for installations under new pavement or as linear feet (meters) excavated and restored. For installations in trenched areas, each detector includes all conduit trench-paved areas, excavation, restoration and concrete Class C as required. Payment would be made as "Loop Detector Installation".

Measure overhead Microwave Detectors as a complete unit, including all mounting hardware.

Measure overheight Infrared Detectors (two-eyed) as one complete installation, including all mounting hardware.

Measure pedestrian pushbutton with signs as a complete unit in place, including all hardware, tested and accepted.

1328.09 Basis of Payment. City will make payment at the Contract unit price bid as specified per each item and as full compensation for all labor, materials, tools, equipment and incidentals necessary to furnish and install the items as specified, complete, tested and accepted and in accordance with the details.

Item	Unit	Description
1328	Each	___ detector amplifier, installation Only
1328	Ft (m)	___ detector pavement cutting
1328	Ft ² . (m ²)	___ Loop detector installation, with new pavement
1328	Ft. (m)	Loop detector installation in trenched area
1328	Each	Overhead microwave detector installation
1328	Each	Overheight infrared detector
1328	Each	Pedestrian pushbutton with associated signs
1328	Each	Video Detection

Item 1329 Traffic Control Signs and Installations

1329.01 Internally Illuminated Signs. This work consists of furnishing and installing internally illuminated signs with one or more plastic faces in accordance with these specifications and as plans and details show.

This specification covers the fabrication of internally illuminated signs and includes the sign frame, lamp holders, ballasts, terminals, wiring, and mounting hubs. The nature of the construction of these signs and the need for them to accept lamps and lexan sign faces, requires that samples be provided before an award is made. This specification does require that the sign cabinets have rounded corners and "U" channels to accept lexan sign faces that have two thicknesses, depending on the sign size and also that have 1-1/2 inch (38 mm) radius corners.

A. Definitions.

Sign - Means the entire assembly including frame, permanently attached aluminum face for single-faced sign, mounting hubs, top frame reinforcement, lamps, lamp holders, ballasts, terminals, and wiring.

Frame - Means the members forming the top, ends and bottom enclosure of the sign.

Faces - The sides of the sign that face traffic.

Plastic Face - The entire assembly of plastic and paint forming the complete sign face.

Background. - The main panel of plastic which slides into the U grooves of the sign case and on which all specified legends are placed.

Legend - Letters, numbers, emblems, route markers, lines and/or arrows forming message.

B. Sign Design. The illuminated sign is an all-aluminum box designed and constructed so the sign, complete with face or faces, will hang plumb when suspended.

1. Cast-Mechanical Construction. All metallic parts are of aluminum of 0.100 inches (2.5 mm) thick at all points. The aluminum is of high strength alloy type at least equal in strength and abrasion resistance to 3003H14.

2. Wind Load. The material, design and construction is such that the case will withstand continuous wind loads up to 30 psf (1,500 Pa).

3. Construction. Construct case to the size shown on the plans and Table 1329.A. A single-faced sign is designed for one plastic face and one permanently attached aluminum face. A double-faced sign is designed for two plastic faces. Plastic faces are retained in "U" shaped tracks designed to permit easy removal of the faces by sliding them out of the case on the side or at the bottom for legend changing and electrical maintenance.

Table 1329.A – Sign Dimensions and Mechanical Data Size Designation	Case Inside Diameter (Nominal) Modify to Accommodate Tube Length		Frame Cross Section Flange Depth		Overall Thickness of Complete Sign		Number Of Mounting Hubs (c)	Ballast Code Number (a)	Lamp Code (f)	Number of Lamps (b)
	Horizontal	Vertical	Minimum	Maximum	Minimum	Maximum				
24" x 30" (600 mm x 760 mm)	24 inches (600 mm)	30 inches (760 mm)	5/8 inch (16 mm)	3/4 inch (20 mm)	5 inches (130 mm)	8 inches (200 mm)	1	ASB-0620-24- BL-TP	F24T12CWHO	4
30" x 24" (760 mm x 600 mm) 30" x 24" D	30 inches (760 mm)	24 inches (600 mm)	5/8 inch (16 mm)	3/4 inch (20 mm)	5 inches (130 mm) 10 inches (260 mm)	8 inches (200 mm) 12 inches (300 mm)	1 - SF 0 - DF	ASB-0620-24- BL-TP	F24T12CWHO	4
30" x 36" (760 mm x 900 mm)	30 inches (760 mm)	36 inches (900 mm)	5/8 inch (16 mm)	3/4 inch (20 mm)	5 inches (130 mm)	8 inches (200 mm)	1	ASB-0620-24- BL-TP	F36T12CWHO	4
36" x 30" (900 mm x 760 mm)	36 inches (900 mm)	30 inches (760 mm)	5/8 inch (16 mm)	3/4 inch (20 mm)	5 inches (130 mm)	8 inches (200 mm)	2	ASB-0620-24- BL-TP	F36T12CWHO	4
36" x 36" (900 mm x 900 mm) 36" x 36" D	36 inches (900 mm)	36 inches (900 mm)	5/8 inch (16 mm)	3/4 inch (20 mm)	5 inches (130 mm) 10 inches (260 mm)	8 inches (200 mm) 12 inches (300 mm)	2 - SF 2 - DF	ASB-0620-24- BL-TP	F36T12CWHO	4
48" x 48" (1,200 mm x 1,200 mm) 48" x 48" D	48 inches (1,200 mm)	48 inches (1,200 mm)	5/8 inch (16 mm)	3/4 inch (20 mm)	5 inches (130 mm) 10 inches (260 mm)	8 inches (200 mm) 12 inches (300 mm)	2 - SF 2 - DF	ASB-0620-24- BL-TP (2 each)	F48T12CW	6

(a) Numbers are those of the Advanced Ballast Company stated as a guide only.

(b) Lamps mounted vertically or at 45° from vertical must have a rubber sleeve at the bottom lamp base.

(c) Mounting hubs are for 1-1/2 inch pipe size. Mounting hubs for mounting on a 4 inch post is required on the bottom and/or bottom corner of the sign.

(d) Measured with plastic at 70° F (21° C).

(e) Diamond shaped signs (with D on size designation) are square turned at 45° angle.

(f) LED light source in accordance with 1329.01.H.2.

Table 1329.B - Sign Face Dimensions

Size Designation	Visible Plastic Face Area (Minimum)		Plastic Face Dimensions				Plastic Face Thickness		Plastic Face Corner Radius
			Horizontal		Vertical		Minimum	Maximum	
	Horizontal	Vertical	Minimum	Maximum	Minimum	Maximum			
24" x 30" (600 x 760)	22-1/2" (572 mm)	28-1/2" (725 mm)	23-11/16" (602 mm)	23-3/4" (603 mm)	29-11/16" (754 mm)	29-3/4" (755 mm)	0.125" (3 mm)	0.150" (4 mm)	1-1/2" (40 mm)
30" x 24" (760 x 600 mm)	28-1/2" (724 mm)	22-1/2" (572 mm)	29-11/16" (754 mm)	29-3/4" (756 mm)	23-11/16" (602 mm)	23-3/4" (603 mm)	0.125" (3 mm)	0.150" (4 mm)	1-1/2" (40 mm)
30" x 36" (760 x 915 mm)	28-1/2" (724 mm)	34-1/2" (876 mm)	29-11/16" (754 mm)	29-3/4" (756 mm)	35-5/8" (905 mm)	35-11/16" (906 mm)	0.125" (3 mm)	0.150" (4 mm)	1-1/2" (40 mm)
36" x 30" (915 x 760 mm)	34-1/2" (876 mm)	28-1/2" (724 mm)	35-5/8" (905 mm)	35-11/16" (906 mm)	29-11/16" (754 mm)	29-3/4" (756 mm)	0.125" (3 mm)	0.150" (4 mm)	1-1/2" (40 mm)
36" x 36" (915 x 915 mm) 36" x 36" D(a) (915 x 915 mm)	34-1/2" (876 mm)	34-1/2" (876 mm)	35-5/8" (905 mm)	35-11/16" (906 mm)	35-5/8" (905 mm)	35-11/16" (906 mm)	0.187" (5 mm)	0.200" (5 mm)	1-1/2" (40 mm)
42" x 36" (1,070 x 915 mm)	40-1/2" (1,029 mm)	34-1/2" (876 mm)	41-9/16" (1,056 mm)	41-5/8" (1,057 mm)	35-5/8" (905 mm)	35-11/16" (906 mm)	0.187" (5 mm)	0.200" (5 mm)	1-1/2" (40 mm)
48" x 30" (1,220 x 760 mm)	46-1/2" (1,181 mm)	28-1/2" (724 mm)	47-9/16" (1,208 mm)	47-5/8" (1,210 mm)	29-11/16" (754 mm)	29-3/4" (756 mm)	0.187" (5 mm)	0.200" (5 mm)	1-1/2" (40 mm)
48" x 36" (1,220 x 915 mm)	46-1/2" (1,181 mm)	34-1/2" (876 mm)	47-9/16" (1,208 mm)	47-5/8" (1,210 mm)	35-5/8" (905 mm)	35-11/16" (906 mm)	0.187" (5 mm)	0.200" (5 mm)	1-1/2" (40 mm)
48" x 48" (1,220 x 1,220 mm) 48" x 48" D(a) (1,220 x 1,220 mm)	46-1/2" (1,181 mm)	46-1/2" (1,181 mm)	47-9/16" (1,208 mm)	47-5/8" (1,210 mm)	47-9/16" (1,208 mm)	47-5/8" (1,210 mm)	0.187" (5 mm)	0.200" (5 mm)	1-1/2" (40 mm)

- (a) Diamond shaped signs (with D on size designation) are square turned at 45° angle.
- (b) Lamps mounted vertically or at 45° from vertical must have a rubber sleeve at the bottom lamp base.
- (c) A mounting hub for mounting on a 4 inch post is required on the bottom and/or bottom corner of the sign.
- (d) Measured with plastic at 70° F (21° C).
- (e) BO designation indicated blankout type sign.

The frame is of an extrusion, casting, or formed member having one-piece cross section with flanges on both ends. It is at least as rigid as an extrusion of this design. The flanges are of "U" type specified for plastic faces and of either the "U" type or the single-flange type for attachment of the aluminum sheet for the blind side of single-faced signs. The frame and aluminum faces have continuously welded seams and are watertight.

The flanges serving as retainers for all faces have a radius of 1-1/2 inches (40 mm) at each corner of the sign. The top of the case frame is reinforced with a piece of 1/8 inch (3 mm) thick aluminum, continuously welded to the inside of the frame, extending the full width inside the frame flanges and running the full length of the frame top. All 24 x 24D, 36 x 36D and 48 x 48D signs are reinforced with 1/8 inch (3 mm) thick aluminum, continuously welded to the inside of the frame extending the width inside the frame flanges and extending up each side, at least 18 inches (450 mm), from the bottom corner. This welding reinforces the top to prevent deformation caused by the stress induced through the mounting hubs, when installed.

Drill four 1/4 inch (6 mm) weep holes, two on each end of the bottom of the frame, except on the 24 x 24D, 36 x 36D, and 48 x 48D signs, which have two weep holes drilled in the bottom corner.

D. Mounting. Attach to the top of the frame the number of 1-1/2 inch (40 mm) pipe size flanged pipe hubs Table 1329.A specifies for mounting purposes.

Paint the hubs the same color as the frame with the threads unpainted and the cable entrance through the hubs.

E. Fastening Devices. All nuts, bolts, screws, and rivets are of stainless steel or high strength silicon bronze.

F. Brightness. Take brightness readings at 118 input line voltage after the first 100 hours of lamp operation with a white plastic face of ROHM & HAAS Plexiglass No.7328 that will be provided by the City. Divide the plastic face into four inch by four inch (100 mm x 100 mm) rectangles and take one reading in the center of each rectangle. Make readings in foot lamberts (candela per m²).

AVERAGE BRIGHTNESS - (B_{AVG}) = The sum of the individual brightness readings divided by the number of readings taken.

MAXIMUM BRIGHTNESS - (B_{MAX}) = The largest reading taken.

MINIMUM BRIGHTNESS - (B_{MIN}) = The smallest reading taken.

RANGE OF AVERAGE BRIGHTNESS - (R) = a percentage calculated as follows:

$$R = 100 \times \frac{B_{MAX} - B_{MIN}}{B_{AVG}}$$

VALUES - THE VALUES ARE AS FOLLOWS:

	Minimum	Maximum
Average Brightness (B_{AVG})	130	190
Range of Average Brightness (R)	55%	

G. Component Mounting. Mount components inside the sign so that no shadows or dark spots appear on the sign face when the sign is illuminated.

H. Lamps. (Furnish signs with lamps.)

1. Fluorescent. Design signs for use with standard universally available T-12 cool white slimline fluorescent lamps in accordance with Table 1329.A.

2. LED. Single Face Signs – Power supply input operating voltage to be 120 VAC, output to be 24 VDC / 60W. Double Face Signs - Power supply input operating voltage to be 120 VAC, output to be 24 VDC/ 80 W or 24VDC/100W depending on number of LED devices being driven. Operate LED units continuously from -40°C to +60°C. Color temperature of LED units to be between 6300 and 6700 Kelvin. Lighting manufacturer to provide mounting support in the form of tubes or brackets that quickly mount and can be easily removed and reinstalled to allow replacement of the LED units. Supplier to submit catalog cuts and shop drawings including power consumption of the units for approval. Provide a 5-year warranty for LED power supply and components.

I. Lampholders. Furnish lampholders constructed of white high-impact plastic with each set consisting of a male and female end. Provide lampholders rated for 660 watts and 600 volts of the two pin, recessed type. Furnish lampholders conforming to Leviton models 465 and 484 or approved equal. Lampholders at the low-voltage end of the lamp are the short-circuiting type, and at the high-voltage end are rated at not less than 600 volts. At the low voltage end, wire the lampholder with the ground conductor so that the primary circuit of the ballast is open when removing any lamp. If the lampholder on only one end of a lamp has a spring, the spring is in the top lampholder for vertically mounted tubes.

J. Ballast. Furnish class P, Type HL, high power factor series ballast that contains no PCB's and is type 2 outdoor compatible. Provide Advance Ballasts System model ASB-0620-24-BL-TP or approved equal. Furnish weather-resistant ballast that gives reliable starting at all ambient temperatures above 20° F (-7° C). Mark the ballast with the following information:

1. Manufacturers' name or trademark and catalog number.
2. Input voltage, frequency and current rating.

3. Open-circuit voltage, power factor and ballast loss (watts).
4. Number of laps, nominal lamp current, lamp length and type.
5. Wiring diagram indicating the correct electrical connection of various leads.

When located on the bottom of the sign, mount ballast on spacers to provide ½ inch (12 mm) clearance with the bottom and bolt it to the bottom of the case using four bolts. When located in other positions in the case, locate the ballast so as to minimize the effect of the weight of the ballast on the balance of the sign and the ability of the sign to hang plumb.

Make lamp and Ballast to be High Output (HO) with F24T12CW/HO tube and 120 volt, 4 tube ballast.

When located on the bottom of the sign, mount ballast on spacers to provide ½ inch (12mm) clearance with the bottom and bolt it to the bottom of the case using four bolts.

K. Terminal Block. Locate a terminal block having a minimum of four terminals near the cable entrance. Terminate wires for interior power connections on this terminal block. No external wires are supplied.

L. Wiring. All wiring must be appliance Wire No. 18 AWG, with at least 16 copper strands and thermoplastic insulation at least 2/64 inch (0.8 mm) thick, and insulation rated for 221° F (105° C). Color code all wires with white used for the ground wire and color-code wires for the ungrounded wires of the supply circuit. The secondary circuit or high voltage circuit corresponds to the color-coding of the ballast leads. Run wire neatly in an aluminum raceway or flexible aluminum conduit and the edges of the openings in sheet metal or conduit, which offers protection from abrasion by means of a bushing grommet or rolled edge. Securely clamp or reliably hold in place the conduit at all openings and support the wiring so that the bottom of a sign is cleared by not less than 1/2 inch (12 mm).

Make splices mechanically and electrically secure with an acceptable splicing device.

Confine ballast lead splices to the ballast junction boxes and the raceway.

Do not strip the insulation on the wires at connection points any further than is necessary. Bare conductor does not overhang the edge of the base to which it is connected. Make wires fastened to lampholder terminals mechanically and electrically secure.

M. Marking. Mark each sign case on an inside surface with the Manufacturer's name and the date manufactured.

N. Painting. Prime the interior and exterior of the case, and bake the unit after each coat.

1. Exterior: Paint the exterior of the cabinet and the mounting hub black in accordance with Federal Color No. 17038.
2. Interior: Paint the interior a non-yellowing white in accordance with Federal Color No. 17875.

O. Plastic Face.

1. Material. The face is of cast translucent plastic of acrylic resin type matching the following Rohm and Haas Plexiglass numbers in weathering, structural, and optical properties or a Lexan material where plans specify:

White	W 7328
Yellow	2016

Material is of the thickness Table 1329.B specifies.

2. Legend. Apply a painted legend using a brand of paint the plastic Manufacturer specifies, using the silk screen or spray latex process. Over the painted legend, apply a clear protective coating of a brand the plastic Manufacturer specifies. Show face designs and colors as details specify.

Provide black painted legends, when plans specify, that are opaque.

Provide red, green and blue painted legends, when plans specify, that are translucent, and of a type which will transmit an amount and color of light which is not distinguishable from the light transmitted by the materials that the plans specify.

When plans specify red, green and blue painted legends, match the following Rohm & Haas numbers in optical properties:

Red	2214
Green *	2280
Blue	2114

* Except street name signs (see Paragraph "P").

P. Street Name Signs. Make street name sign faces Lexan or approved equal. The text consists of white letters on a dark green background. The white letters and numbers require a vinyl type translucent paint. The background dark green conforms to Federal Color #14109.

Q. Installation. Include mounting hardware in the item furnished and as indicated in Table 1327 for the mounting arrangement plans indicate. Make the installation and all hardware in accordance with the requirements of the details.

Except street name signs (see Paragraph "P").

1329.02 Mechanically Operated Vane Type Signs.

A. General. The sign consists of two electrically driven hinged outer panels (vanes), which close over a center panel or open to expose the sign face. The outer panels open and close through 180°.

Make the "Blank Out Type" a single message type so that when the outer panels close over the center panel, no message is visible. When the outer panels open, both the outer and center panels form the specified sign face.

Make the "Dual-Message Type" a two-message type so that the movable panels when open form one sign face with the center panel as the open blankout type, and when the movable panels close over the center panel form a second message with the extended portion of the center panel. This type requires that the center panel extend to line up with the opened movable panels and with the movable panels painted on both sides.

B. Sign Face Blank and Panels. Make the sign face and panels a minimum 0.125 inch (3 mm) thick 6061-T6 aluminum with radius corners. Properly degrease the aluminum and etch or treat it with a light, tightly adherent amorphous chromate conversion coating, free of any powdery residue, ranging in color from silvery iridescent to a pale yellow, conforming to ASTM B449-67, Class 2, 10-35 mg per ft² (110-380 mg per m²) with a median of 25 mg per ft² (270 mg per m²) as the optimum coating weight. The sign forms an essentially plane surface when opened.

C. Sign Face. The sign when opened, or closed, if bearing dual messages, accommodates the standard designs of Manual on Uniform Traffic Control Devices. Make the sizes 24 inches by 24 inches (610 mm x 610 mm), 24 inches by 30 inches (610 mm x 760 mm), 30 inches by 30 inches (760 mm x 760 mm), 30 inches by 36 inches (760 mm x 915 mm) as plans specify. Message, border and background color conforms to the Manual on Uniform Traffic Control Devices.

The face is reflectorized with the sheeting, painted and sealed with a clear coating.

D. Frame. Make the frame 0.250 inch x 1 inch x 1 inch (6 mm x 25 mm x 25 mm) 6061-T6 aluminum angle with 0.125 inch (3 mm) aluminum brackets with standard hub holes and one wire hole. Make the frame and brackets of welded aluminum construction.

Enclose the sign-activating mechanism in a corrosion-resistant box, constructed of a minimum of .060 inch (1.5 mm) 3003 H-14 aluminum with a housing cover of minimum 0.125 inch (3 mm) 300 H-14 aluminum. The enclosure meets NEMA 3R requirements for raintight applications.

E. Working Mechanism. The mechanical drive mechanism consists of a roller chain drive, cam-driven, self-locking device with positive drive on both cycles with spring override. All working parts are to be cadmium-plated steel. The motor is magnetic brake non-reversing, gear reduction type, 115 volts three amp developing minimum torque of 170 lbs. (230 N-m) at six to eight RPM, with direct drive from output shaft to operating cam. Provide a microswitch rated for 15 amps at 115 volts.

Enclose the motor in a galvanized steel cover positioned below the sign drive mechanism, with the gear reduction drive protruding through the housing to connect with the cam.

Make all screws, bolts, nuts, sprockets and washers cadmium-plated steel.

Make the chain drive 1/4 inch (6.5 mm) pitch cadmium-plated steel-rolled chain.

Hinges consist of three pivot points on each panel. Make pivots of cadmium-plated steel and attach them with bolts to threaded holes to the panels. Pivots have brass bushings.

F. Mounting. The mounting assembly consists of mounting brackets or hubs, with 1-1/2 inch (38 mm) pipe arms and "U" or saddle clamps for securing the sign assembly to a post or drop pipe (with weather head) as plans specify.

Make at least two mounting assemblies with the material constructed as follows:

1. U-Clamp - Construct of 3/16 inch (5 mm) cadmium or zinc-coated steel and bracket with formed radius as plans specify, with 1/2 inch (12 mm) "U" bolt of welded construction or painted cast iron of equal strength and design.

OR

2. Sign Mounting Clamp - Welded construction with 3/8 inch (10 mm) "U" bolt and full grip clamp, with 1-1/2 inch (38 mm) standard tubing and 10-gauge steel plate or cast iron of equal strength and design, with standard hub hole pattern.

3. Hub - Plate is 10 gauge steel or cast iron of equal strength and design, with standard hub hole pattern, welded 1-1/2 inch (38 mm) standard pipe collar or nipple.

Where plans specify span wire or mast arm mounting, provide a 1-1/2 inch (38 mm), schedule 40, galvanized steel pipe of the length required, a weatherhead and balance adjuster and span wire suspension clamp or mast arm bracket. Install the assembled sign as details show.

G. Miscellaneous Requirements.

Provide complete sign units weighing not more than 55 pounds (25 Kg) each.

Construct units so that the open or closure time through 180° is less than six seconds.

Enclose mechanism and protect to function in a wide range of environmental conditions including rain, snow, wind and temperatures from -40° F to 150° F (-40° C-70° C).

Construct units so that the sign does not normally require periodic lubrication, cleaning or seasonal adjustment.

Do not damage the sign by forcing the panels open or closed within normal operating range.

1309.03 Signs, Flat Sheet Type. Signs not required to be internally illuminated are of the flat sheet type fabricated from aluminum, painted and reflectorized in accordance with Item 630; Reflective green sheeting, Type G.

Signs are in accordance with the standard designs of the Manual on Uniform Traffic Control Devices and of the size and legend plans and details indicate.

City will make payment for mounting hardware and installing signs under the specified attachment.

1329.04 Sign Attachments.

- A. General.** The work of this item consists of furnishing and installing the sign provided under Item 1329.03, with the hardware as specified for the type mounting attachments. Install the sign and attachment assembly in accordance with the plans and details.
- B. Span Wire Mounted Sign Attachments.** The work of this item includes aluminum drop pipe, cast aluminum span wire suspension clamp, cast aluminum weatherhead and galvanized cast iron balance adjuster, lead slug, pipe cap, and pipe straps and hardware.
- C. Mast Arm Mounted Sign Attachments.** The work of this item includes drop pipe, lead slug, pipe cap and straps, mast and clamp and hardware.
- D. Bridge or Wall Mounted Attachments.** The work of this item includes angle brackets, anchoring hardware and miscellaneous hardware.
- E. Plaque Attachments.** Where plans specify a reflectorized sign (or plaque) attached to an illuminated sign and/or traffic signal head, such sign attachment, which includes all hardware required for the attachment, is incidental to the payment of the illuminated sign and/or traffic signal head.

Sign notes and quantities indicate payment and quantity for the reflectorized sign.

- F. Materials.** All hardware and materials required are of the non-corrosive materials as details specify.

1329.05 Method of Measurement. Measure internally illuminated and mechanically operated vane type signs as a complete unit in place, including all lamps (for illuminated signs), sign faces with the specified legend(s), all components and mechanisms and all mounting hardware.

Measure signs, flat sheet type, as the actual number of square feet of signs furnished, erected, and accepted. Determine measurement for square, rectangular, circular, or irregular shaped signs by multiplying the largest dimensions of width and height. Determine measurement for triangular shaped signs by multiplying the largest dimension of width and one-half the largest dimension of height.

Measure sign attachment assemblies as complete units by type, furnished and installed complete in place and accepted with the specified sign(s) included but furnished under its own item of payment. This includes all clamps, pipes, hangers, brackets, hardware and incidentals as indicated for each type.

1329.06 Basis of Payment. City will make payment at the Contract unit price bid as each item specifies, and as full compensation for all labor, materials, tools, equipment and incidentals necessary to furnish and install the items as plans specify, complete, tested and accepted.

Item	Unit	Description
-------------	-------------	--------------------

1329	Each	Internally illuminated sign, ___ face, _____ light source, ___ inches x ___ inches.
1329	Each	Mechanically operated vane type sign, ___ type, ___ inches x ___ inches.
1329	Ft ² (m ²)	Signs, flat sheet type.
1329	Each	_____ mounted sign attachment.

Item 1330 Pavement Marker Buttons and Longitudinal Channelizing Systems

1330.01 Pavement Marker Buttons. The marker is a snowplowable type unit constructed of cast iron with an acrylic prismatic reflector. Implant the unit in the roadway and secure with an epoxy adhesive.

Provide markers that are Stimsonite Model 96 or 96 LP as plans specify, or approved equals.

The work of this item includes pavement cutting using a concrete saw with a multiple blade arrangement to provide a cut to match the contour of the marker housing.

Clean and dry the sawed excavation using a brush or air blast from a compressed air source.

Pour and mix epoxy adhesive in accordance with Manufacturer's instructions.

1330.02 Longitudinal Channelizing Systems. This specification covers a longitudinal channelizing system that consists of three components. The first component is a series of interlocking, raised separator units that help keep moving traffic along a particular path. The second component is a high target vertical marker that attaches to the separator units. The final component is a profile reflector that enhances the reflectivity of the system. The entire system, when installed, provides a traffic lane barrier that keeps vehicles within their lanes, while allowing an emergency vehicle the ability to go over the barrier at lower speeds.

1330.03 Raised Separator. Provide raised separators consisting of two basic units: a separator unit and an end unit. Fabricate the raised separator of recycled plastic with a sufficiently durable mass to achieve a weight of at least ten pounds per linear foot (15 kg per meter). Provide separators that are a minimum of ten inches (255 mm) and a maximum of 12 inches (305 mm) in width, and a minimum of 3-1/2 inches (90 mm) and a maximum of four inches (100 mm) in height with a cross section that is gently curved so as to provide minimal resistance to vehicle tires, thereby allowing emergency vehicles to cross the separator. To increase target value in daylight hours, provide separator with the entire rounded surface colored white or yellow to conform to the traffic pavement markings that they supplement.

For ease of installation, provide the raised separator units in portable sections, 3.33 feet (1 meter) in length. Furnish units that structurally fasten together securely by bolting each unit to a connecting metal device molded securely into the adjoining unit. Use tapered end units at

the beginning and end of each run of separator to form a gradual increase in height from the pavement level to the top of the separator. Provide tapered end units 1.5 feet (460 mm) in length that are capable of receiving a reflecting element. Fix the separator to the roadway by removable expansion anchors spaced as recommended by the separator Manufacturer. Provide the anchors and include their cost in the unit price for the separator units.

Provide individual separator units that have a receptacle for the installation of a bow shaped device with retro-reflectivity on the top and sides facing motorists.

Provide raised separator system capable of being deployed without being anchored to the roadway by fasteners. Furnish molded in metal connecting devices capable of holding the individual separator units together and in position on the roadway without the need for fasteners. Additionally, furnish system capable of being installed, removed and shifted from one lane to the next via a truck mounted conveyor system.

1330.04 High Target Value Channelizers. Affix each high target value channelizer to a detachable flexible rubber boot or other device that supports the channelizer in a vertical position, and is capable of restoring the channelizer to the vertical position if struck by a vehicle. Furnish channelizers composed of high impact plastic that accommodates Type III retro-reflective sheeting. Generally, provide reflective sheeting of the same color as the raised separator units.

Use elliptical channelizers when traffic is moving generally parallel to the traffic separator. Mount elliptical channelizers between 40 and 47 inches (1,015 and 1,195 mm) above the roadway and between eight to ten inches wide. Provide elliptical channelizers that accommodate retro-reflective Type III sheeting between 29 and 30 inches (740 and 760 mm) in height and between 7-3/4 and eight inches (197 and 203 mm) in width providing a reflective area of 230 to 255 square inches (0.15 to 0.16 m²) facing the traffic. Install markers along the length of the separator system to provide an on-center spacing of approximately 6.7 feet (2 meters).

Provide round channelizers that are between four and six inches (102 and 152 mm) in diameter. Furnish round vertical markers that have an overall round appearance so that reflective sheeting is visible from any direction around the round channelizer. Round vertical markers must accommodate at least two four-inch (102 mm) bands of reflective sheeting providing a retro-reflective area of 50 to 100 square inches (0.03 to 0.06 m²) facing traffic. Mount round channelizers at a height of 40 to 44 inches (1.0 to 1.1 meters) above the roadway. Install the round markers along the length of the separator system to provide an on-center spacing of approximately 6.7 feet (2 meters).

1330.05 Reflecting Element. For motorist safety at night, reflecting elements must depict the raised profile of the separator units at night. Thus, design reflecting elements to adhere to the top and both sides of the separator units. Design snap-in arcs with seven reflecting elements on each side to depict the raised profile of the lane separator and install on each separator unit as well as each male end unit. Provide individual reflective "cat's eyes" that have the following photometric performance data in millicandela per lux (mcd/lux) for the inclination angle of 0°:

Angle of	Entrance	White	Amber	Red
----------	----------	-------	-------	-----

Observation α	Angle β	(mcd/lux)	(mcd/lux)	(mcd/lux)
0.3°	5°	140	70	28
0.5°	10°	90	45	18
1.0°	10°	36	18	7.2
2.0°	15°	4.6	2.3	0.9

1330.06 Warranty. Vendor certifies that the Manufacturer of the system will provide a 100 percent Manufacturer's warranty for damage to the raised separator units, end units and reflecting elements for the first two years against all normal vehicular roadway traffic, and the same pro-rated warranty averaging at least 50 percent of the replacement value for three additional years. The Manufacturer must also warrant the system components to be free from defects in workmanship and material for a period of two years from the date of shipment. Vendor must provide a copy of the Federal Highway Administration (FHWA) approval letter accepting the Longitudinal Channelizer system's NCHRP350 test results. Failure to include these warranties will result in the bid being deemed non-responsive. For the safety of the motoring public and to establish cost worthiness, the separator system must have a minimum of three years of on-road experience.

1330.07 Method of Measurement. Measure pavement marker buttons as a complete unit in place, including sawcutting, cleaning and epoxy adhesive. Measure raised separator unit including tapered end sections by the linear feet (meters) completed and accepted in place. Measure the channelizers (elliptical and round) by the number of each completed and accepted in place.

1330.08 Basis of Payment. City will make payment at the Contract unit price bid for each item, by type, furnished and installed and in full compensation for all labor, materials, tools, equipment, and incidentals necessary for a completed and accepted item.

Item	Unit	Description
1330	Each	Pavement marker button, ___ type
1330	Linear Foot (meter)	Raised Separator unit, (white / yellow), including tapered end sections and matching reflecting element.
1330	Each	Channelizers, elliptical, (white / yellow), including reflective sheeting
1330	Each	Channelizers, round, (white / yellow), (with/without) matching reflective band.

Item 1331 Traffic Island Lighting

1331.01 Traffic Island Lighting. The City will furnish traffic island light equipment. Where plans specify an overhead type, the City will furnish the fixture complete with lamp.

Where plans specify the pedestal type, the City will furnish the globe fixture complete with lamp.

Before pouring the concrete for the construction of the traffic island, coordinate the casting of the cone type fixture and/or pedestal anchor bolts, and connection of conduit from the island light to the specified pull box. Install a ground rod in the nearest pullbox as details show.

Include the conduit, ground rod and pedestal (where plans specify) under each item of bid, but include with the pedestal bid item conduit ells where pedestals are located adjacent to pullboxes. Provide pipe fittings and hardware for mounting the pedestal fixture to the post.

1331.02 Method of Measurement. Measure traffic island lights as a complete unit in place, including pipe fittings, nipples and all hardware required to mount the fixtures.

1331.03 Basis of Payment. City will make payment at the Contract unit price bid for each item, by type, installed complete, tested and accepted and as full compensation for all labor, materials, tools, equipment and incidentals.

Item	Unit	Description
1331	Each	Traffic island light, ___ type, installation only

Item 1332 Relocation of Existing Equipment

1332.01 Relocation of Existing Equipment. Equipment plans specify to be relocated may be poles, signs, signal heads, luminaires, island lights or other. Carefully remove the specified equipment and relocate the equipment where plans indicate.

After removal, inspect and clean equipment. Remove any rusted areas, spot prime and paint in accordance with Item 1317.

When relocating poles and posts, provide new anchor bolts conforming to Item 1318, the cost of which is incidental. Ensure that new foundations for relocated poles and posts are in accordance with the plans and details. Foundation work will be paid per Item 1319.

When relocating signs, signal heads or other specified devices, furnish new materials and hardware as required to properly reinstall the equipment complete and in accordance with the details. Contractor may reuse salvageable materials with the Engineer's approval. Redlead the new pipe threading when reusing drop pipe and arms by reducing the length. Where existing drop pipe and arms are too short, furnish new pipe. The City will not permit extension pipe pieces with couplings.

Include new hardware and materials required in the payment for the item relocated and make them of non-corrosive material in accordance with the details.

In rewiring relocated equipment, use entire new cable runs or extensions of existing cable as plans specify. Splice new cable to existing cable using approved splicing as details

indicate. Remove or abandon existing cable as plans specify; disconnect abandoned cable completely at both ends. Cut the ends cut so that existing conductor ends are not exposed beyond the insulation. The conductors are then doubled back over the jacket and taped with at least three layers of approved weatherproof electrical tape.

Furnish new cable under the respective Item 1323.

Relamp signal, sign and luminaires after reinstallation. Include lamps with the payment of the item relocated and ensure that they meet the requirements of the application under Items 1326 and 1329.

1332.02 Method of Measurement. Measure relocated equipment as a complete unit by type in place, tested, and accepted and include relocating, rewiring, splicing and new and/or modification of existing hardware, lamps, painting and removal and disposal of unusable materials and equipment and new anchor bolts for poles and pedestals.

1332.03 Basis of Payment. City will make payment at the Contract unit price bid for each item, by type, relocated complete, tested and accepted as full compensation for all labor, materials, tools, equipment and incidentals.

Item	Unit	Description
1332	Each	Relocation of existing ____ (specified equipment)

Item 1333 Modification of Existing Lighting Circuits

1333.01 Modification of Existing Lighting Circuits. Where plans specify, provide labor and materials to modify and reconnect the specified lighting circuit complete as plans and details indicate.

Schedule work so as not to disable the existing lighting circuit during the hours when the circuit is normally operative.

Ensure that all materials and equipment used meet the requirements of the items as specified herein.

1333.02 Method of Measurement. Measure modification of existing lighting circuits as complete units in place, tested and accepted, including all materials and equipment as plans specify.

1333.03 Basis of Payment. The City will make payment at the Contract unit price bid for each circuit modified complete, tested and accepted and as full compensation for all labor, materials, tools, equipment and incidentals.

Item	Unit	Description
1333	Each	Modification of existing lighting circuit No. _____ .

Item 1334 Restoration of Work Areas

Keep adequate walking areas for pedestrians clear of equipment, materials, supplies and excavated materials at all times.

Move any excavated material obstructing any portion of the sidewalk or street area at the end of the working day so as not to obstruct the sidewalk or street area.

Adequately barricade and light excavated material off of, but not adjacent to the sidewalk area.

Neatly restore sidewalks, driveways, and sodded areas to the satisfaction of the City. Restore concrete sidewalks and driveways from joint to joint. Restore paved areas in accordance with the latest version of the City of Cincinnati, Engineering Division "Street Restoration Book" as Cincinnati Municipal Code, Section 721-35 stipulates.

Contractor may remove forms in accordance with 511.13. Remove all forms before backfilling. Do not use excavated material as backfill unless the Engineer approves. Place backfill in layers and compacted to prevent future settlement of backfill materials. Dispose of the excavated material not needed and/or backfilled lawfully offsite.

Restore all sodded areas using excavated material with the top four inches (100 mm) of restoration being topsoil compacted to grade.

Furnish well-rooted Kentucky Bluegrass or Canadian Bluegrass containing a growth of not more than 30 percent of other grasses and clovers, unless plans specify otherwise.

Restoration is incidental to the payment of the various items requiring restoration.

Item 1335 Cable and Pole Identification

Identify all lighting cable by circuit with tags in accordance with Item 725. Identify using adhesive decals with reflective characters and background installed as details show.

The City furnishes pole decals, and the Contractor furnishes circuit cable tags.

Providing and installing these items is incidental to the payment of the cable and poles.

Item 1336 Method of Payment

The City will make payment for accepted quantities of street lighting and traffic control items provided in these specifications at the prices the Contract specifies.

Method of Payment will be one of the following:

- A.** Unit price for each item.

B. Lump sum for the entire Contract (by location or circuit).

C. Lump sum for the entire Contract with unit prices for major items to cover possible changes of quantities, which may arise during the Contract period.

The enclosed specification items are based on unit price bidding, with the Contractor furnishing all materials and equipment except that which is specified as furnished by the City. Where the City specifies in a Contract that it will furnish equipment, make adjustments for bidding these items where the work is reduced to installation and materials required to complete the item of work.

Where the City specifies that the Contract (by location or circuits within a Contract area) will be bid on a lump sum basis, the basis of payment includes all accepted quantities of equipment and materials as plans specify, as required to provide a complete item, in place, tested and accepted. The basis of measurement includes the work requirements of all the various items required.

Item 1337 Turn On-Off Records

Notify the City Traffic Engineer and provide a written record thereof when turning on or off any electrical operated lighting and traffic control device, and when installing and removing all electrical and non-electrical devices.

This is to provide the City of Cincinnati with information for public record and for purposes of energy billing.

| Record the time of day and the date along with the dates for burn tests.

| The City will make payment incidental to items so noted.